



## Rack Panel connector incorporating Antenna link for GPS or ERTMS transmissions

- Railways approved float mount connector.
- Modular type, with mixed power signal and coax contacts.
- Featuring 1 coaxial contact #8 (GPS or ERTMS).
- Single size: 14 units (5.5mm).
- Cable length: from 0.25m to 5.0m, by multiple of 0.25m.

### About ERTMS

The European Rail Traffic Management System (ERTMS) was originated by the European Community (EC) to create a unique Automatic Train Control and railways management system to enable interoperability throughout the European rail network.

ERTMS is the combination of the new control-command system ETCS (European Train Control System) and the new GSM-R radio system for voice and data communication.

The ERTMS project has been set up to ensure safe operation of the trains in the network and to deal with the traffic and infrastructure management issues enabling the optimisation of the capacity of the lines and the utilisation of the fleet.

The ERTMS project involves 6 major suppliers in 7 countries (UK, France, Spain, the Netherlands, Germany, Switzerland and Italy).

### Connector Configurations

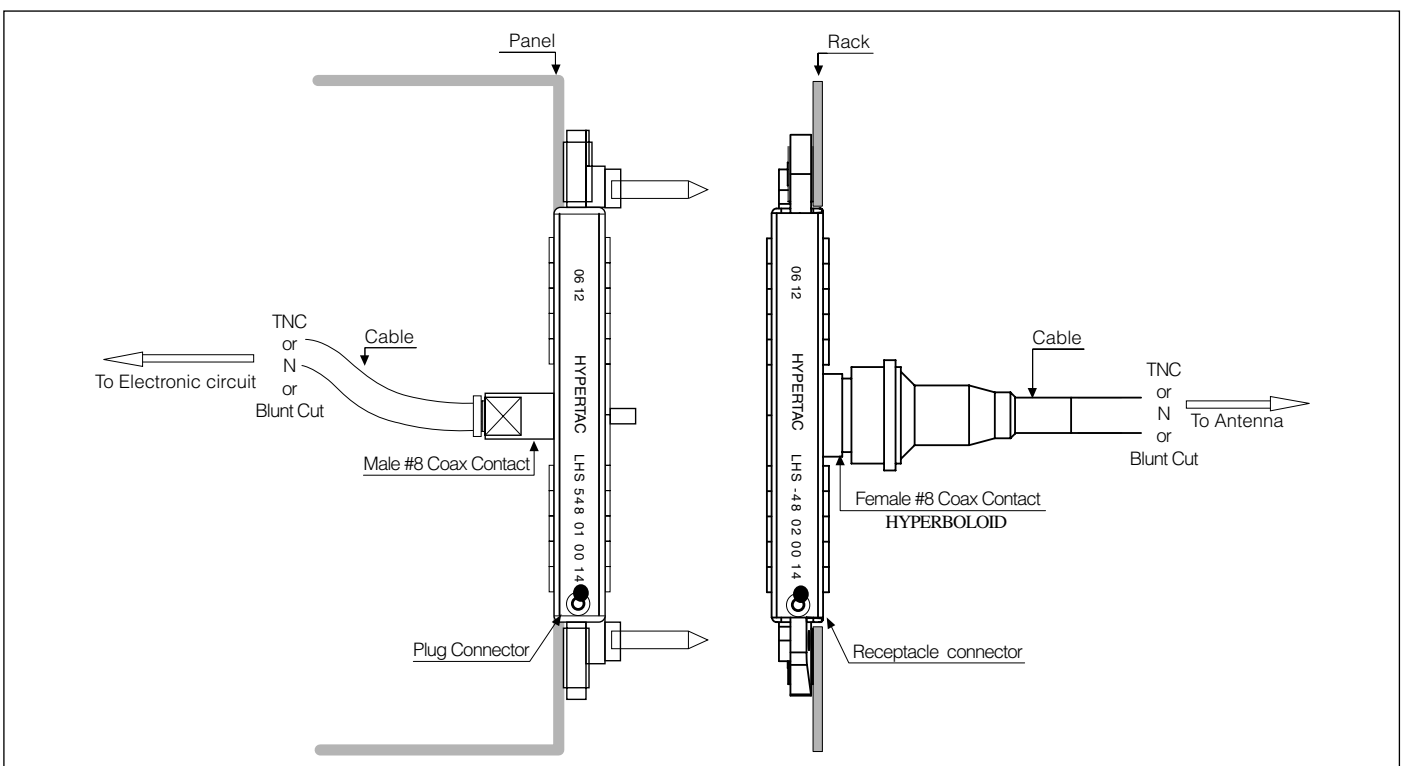

### Ordering information

#### MATERIALS AND PLATINGS

Frame	Soft Steel (Zinc coated)
Side flange	Polycarbonate
Insulator	Polycarbonate
Pin & socket body	Brass, Au/Ni
Socket wires	Copper alloy, Au/Ni
Pin	Au/Ni
Floating eyelets	Brass (Ni plated)

#### ENVIRONMENTAL & MECHANICAL

Temperature range	- 40 °C to 100 °C
Fire classification	Level 2 following NF F 16-102
Salt spray test	96 hours
Acid withstanding	Following NF F 61-032 par. 11.4.6
Vibration Withstanding	5g / 25 to 250 Hz
Insulator mechanical resistance	1000 N
Max torque for auto threading screws	75 Ncm

#### ELECTRICAL CHARACTERISTICS

Contact Ø	Ø 1.50	Ø 2.50	Ø 3.50
Creepage distance	1.85 mm	2.25 mm	4.05 mm
Clearance distance	1.25 mm	3.40 mm	5.40 mm
Working current	8 A	16 A	25 A
Insulation resistance	≥ 5.10 <sup>3</sup> MΩ		
Contact resistance	≤ 2.50 mΩ	≤ 1.00 mΩ	≤ 0.80 mΩ
Dielectric withstanding voltage	1500 Vrms	2000 Vrms	3000 Vrms
Voltage rating	110 V	220 V	220 V
Contact retention	40 N	50 N	70 N
Maxi male contact mass	1.10 g	2.90 g	4.90 g
Maxi female contact mass	0.70 g	1.60 g	2.70 g
IF/SF* (Max value)	1.60N	9.00N	10.00N

Coaxial contact Ø	Ø 3.65
Nominal impedance	50 Ω
Frequency range	1.5GHz
RF Transmission Loss	0.05db at 1GHz 0.06db at 1.5GHz

\*IF/SF: Insertion and separation force according to NF F 61-032

## Antenna cable assembly receptacle connector

### Cable & contact technical characteristics

Impedance	50 Ω ±1Ω		
<b>Cable 1/4" mechanical characteristics</b>			
Zero halogen			
External diameter	6.40mm		
Static bending radius	25mm mini		
Dynamic bending radius	45mm mini		
Max pull force	500N		
α @ 1500MHz	24db/100m		
<b>Transmission losses</b>			
	<b>1GHz</b>	<b>1.5GHz</b>	
Hypertac coaxial contact	0.05db	0.06db	
Coaxial cable	19db/100m	24db/100m	
TNC contact	-	0.06db	
N contact	0.05db	-	
<b>Cable assembly transmission loss: versus length</b>			
<b>Length</b>	<b>1GHz</b>	<b>1.5GHz</b>	
0.25m	0.15db	0.18db	
0.50m	0.2db	0.24db	
0.75m	0.25db	0.30db	
1m	0.29db	0.36db	
1.25m	0.34db	0.42db	
1.50m	0.39db	0.48db	
1.75m	0.44db	0.54db	
2m	0.48db	0.60db	
2.25m	0.53db	0.66db	
2.50m	0.58db	0.72db	
2.75m	0.63db	0.78db	
3m	0.67db	0.84db	
3.25m	0.72db	0.90db	
3.50m	0.77db	0.96db	
3.75m	0.82db	1.02db	
4m	0.86db	1.08db	
4.25m	0.91db	1.14db	
4.50m	0.96db	1.20db	
4.75m	1.01db	1.26db	
5m	1.05db	1.32db	

**Main Layout**

(For other layouts, please consult your representative.)

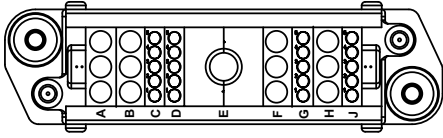

**Layout -31**

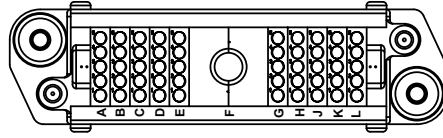

**Layout -48**

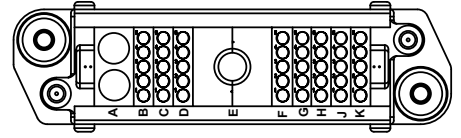

**Layout -51**

**Part Numbering**

SERIES		LH	-	-	--	--	--	14	-	-
MODEL										
<b>S</b>	Standard									
<b>Z</b>	Customer specific program									
COAXIAL CABLE ASSEMBLY DETAILS										
<b>5</b>	Delivered without the #8 coaxial contact									
<b>A to V</b>	Delivered with the #8 coaxial contact cable assembly, <b>A to V</b> length table (meter)									
<b>A:</b> 0.25	<b>B:</b> 0.50	<b>C:</b> 0.75	<b>D:</b> 1	<b>E:</b> 1.25	<b>F:</b> 1.50	<b>G:</b> 1.75	<b>H:</b> 2	<b>J:</b> 2.25	<b>K:</b> 2.50	
<b>L:</b> 2.75	<b>M:</b> 3	<b>N:</b> 3.25	<b>P:</b> 3.50	<b>Q:</b> 3.75	<b>R:</b> 4	<b>S:</b> 4.25	<b>T:</b> 4.50	<b>U:</b> 4.75	<b>V:</b> 5	
LAYOUT										
<b>31</b>	<b>48</b>	<b>51</b>	Other layout : please consult factory							
PART POLARITY										
<b>01</b>	Plug without contact	<b>13</b>	Plug with male contact							
<b>02</b>	Receptacle without contact	<b>22</b>	Receptacle with female contact							
CONTACT TERMINATION										
<b>00</b>	Without contact	<b>20</b>	Crimp contact							
PITCH NUMBERS										
CONTACT TYPE										
<b>S</b>	Straight	<b>C</b>	Bent 90°							
CABLE TYPE										

**Cable assembly dimensions**

**Straight contact termination**  
**Contact P/N: 037010 2-XF - - - -**

**90° contact termination**  
**contact P/N: 037011 2-XF - - - -**

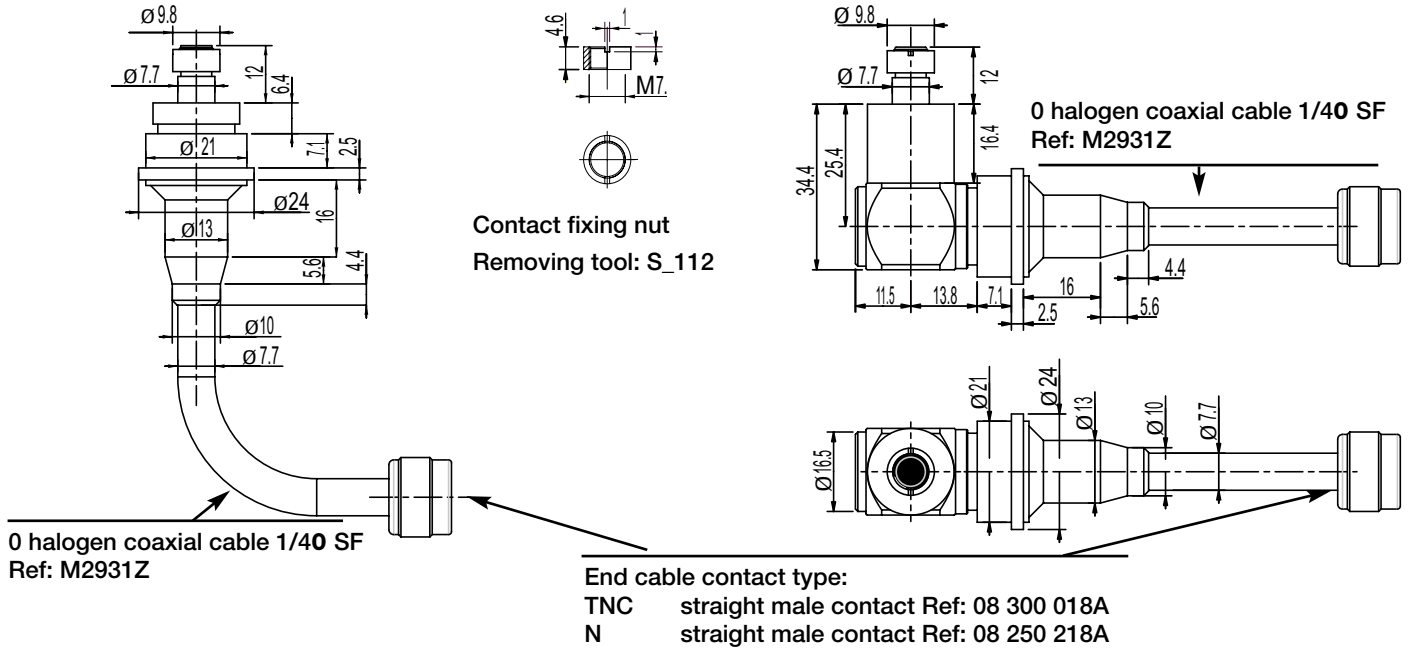

**Cable assembly part numbering**

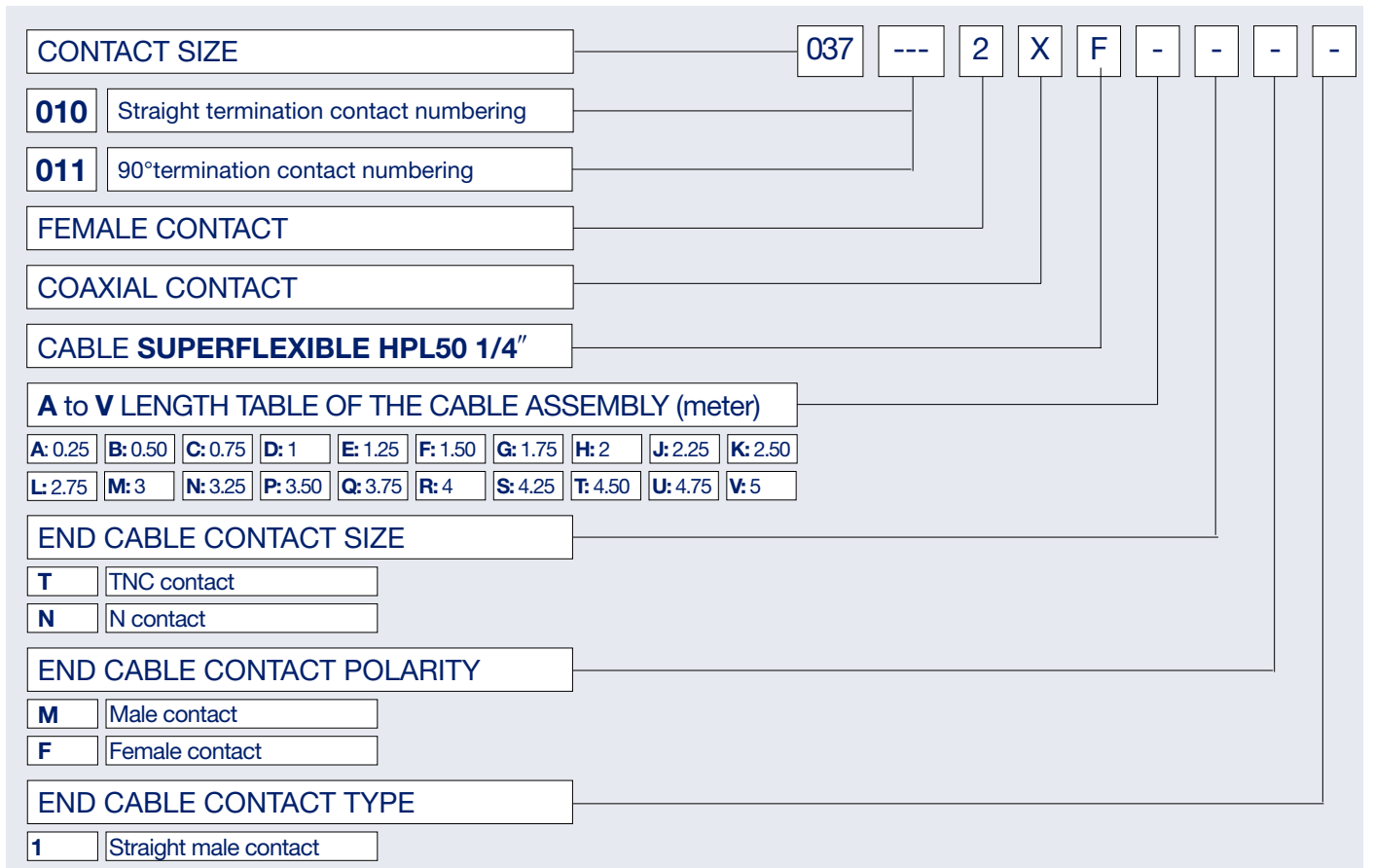

Dimensions are in mm

**Contacts - crimp terminations**

**Receptacle mating side view**

**Plug mating side view**

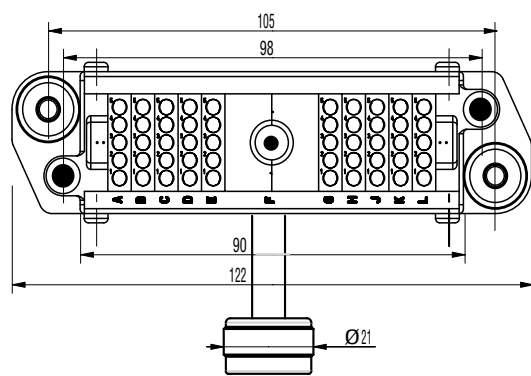
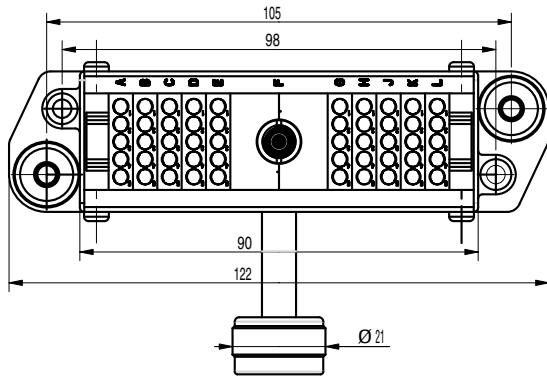
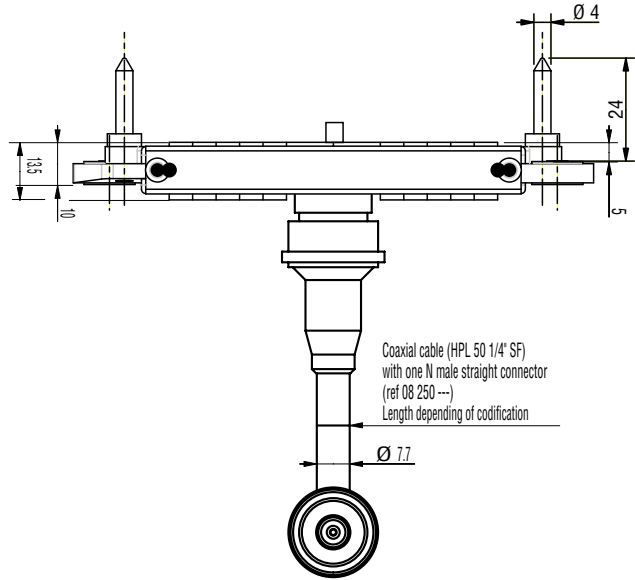
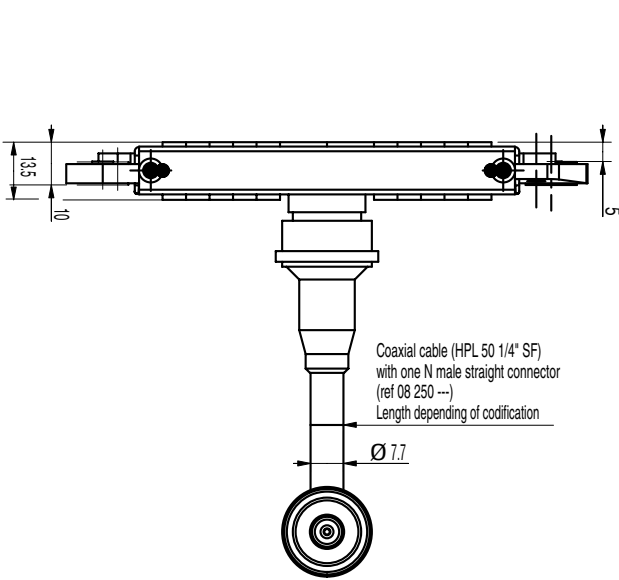

Dimensions are in mm