

## Description

Single pole thermal-magnetic circuit breaker with tease-free, trip-free, snap action mechanism and two button operation (M-type TM CBE to EN 60934). Featuring a narrow profile housing, recessed terminals, standard EN rail mounting, and precision CBE performance. Approved to CBE standard EN 60934 (IEC 60934).

## Typical applications

Process control systems, instrumentation, rail vehicles.

## Ordering information

| Type No.               |                                   |
|------------------------|-----------------------------------|
| 201                    | single pole, rail mounted version |
| 201-WA                 | low-resistance version            |
| Option                 |                                   |
| 2705                   | fitted with adapter X 200 409 01  |
| Current ratings        |                                   |
| 0.05...16 A            | (type 201)                        |
| 0.05...10 A            | (type 201-WA)                     |
| 201 - .. - .... - 10 A | ordering example                  |

The exact part number required can be built up from the table of choices shown above. Ordering references for optional features should be omitted if not required.

## Standard current ratings and typical internal resistance values

| Current rating (A) | Internal resistance ( $\Omega$ ) |        | Current rating (A) | Internal resistance ( $\Omega$ ) |        |
|--------------------|----------------------------------|--------|--------------------|----------------------------------|--------|
|                    | 201                              | 201-WA |                    | 201                              | 201-WA |
| 0.05               | 447                              | 211    | 3                  | 0.19                             | 0.054  |
| 0.1                | 131                              | 48     | 4                  | 0.090                            | 0.035  |
| 0.2                | 40                               | 12.4   | 5                  | 0.061                            | 0.025  |
| 0.3                | 19.3                             | 5.7    | 6                  | 0.041                            | < 0.02 |
| 0.4                | 10.4                             | 3.1    | 7                  | 0.034                            | < 0.02 |
| 0.5                | 7.1                              | 2.0    | 8                  | < 0.02                           | < 0.02 |
| 0.6                | 4.3                              | 1.32   | 10                 | < 0.02                           | < 0.02 |
| 0.8                | 2.5                              | 0.76   | 12                 | < 0.02                           |        |
| 1                  | 1.67                             | 0.49   | 14                 | < 0.02                           |        |
| 1.5                | 0.61                             | 0.21   | 15                 | < 0.02                           |        |
| 2                  | 0.38                             | 0.101  | 16                 | < 0.02                           |        |
| 2.5                | 0.24                             | 0.078  |                    |                                  |        |

## Approvals

| Authority       | Voltage ratings   | Current ratings |
|-----------------|-------------------|-----------------|
| VDE (EN 60 934) | AC 240 V; DC 65 V | 0.05...16 A     |
| CSA, UL         | AC 250 V; DC 80 V | 0.05...16 A     |



201-...  
standard type

201-WA-...  
low-resistance type

## Technical data

For further details please see chapter: Technical Information

|   |  |   |  |
|---|--|---|--|
| Voltage rating  | AC 240 V (50/60 Hz); DC 65 V<br>(UL: AC 250 V; DC 80 V)  |   |  |
| Current rating range  | 201: 0.05...16 A<br>201-WA: 0.05...10 A  |   |  |
| Typical life  | 5,000 operations at $1 \times I_N$ , inductive<br>5,000 operations at $2 \times I_N$ , resistive   |   |  |
| Ambient temperature   | -30...+60 °C (-22...+140 °F)   |   |  |
| Insulation co-ordination<br>(IEC 60664 and 60664 A)             | rated impulse<br>withstand voltage<br>2.5 kV   | pollution<br>degree<br>2                          | reinforced insulation<br>in operating area |
| Dielectric strength<br>(IEC 60664 and 60664A)<br>operating area | test voltage<br>AC 3,000 V   |   |  |
| Insulation resistance   | > 100 M $\Omega$ (DC 500 V)  |   |  |
| Interrupting capacity $I_{cn}$                                  | 201<br>0.05...0.8 A<br>1...2 A<br>2.5...16 A   | 201-WA<br>0.05...0.2 A<br>0.3...2 A<br>2.5...10 A | self-limiting<br>200 A<br>400 A            |
| Interrupting capacity<br>(UL 1077)                              | $I_N$<br>0.05...16 A<br>0.05...16 A  | $U_N$<br>AC 250 V<br>DC 80 V                      | 1,000 A<br>1,000 A                         |
| Degree of protection<br>(IEC 60529/DIN 40050)                   | operating area IP40<br>terminal area IP20  |   |  |
| Vibration   | 5 g (57-500 Hz), $\pm 0.38$ mm (10-57 Hz)<br>to IEC 60068-2-6, test Fc<br>10 frequency cycles/axis |   |  |
| Shock   | 25 g (11 ms)<br>to IEC 60068-2-27, test Ea   |   |  |
| Corrosion   | 96 hours at 5 % salt mist,<br>to IEC 60068-2-11, test Ka   |   |  |
| Humidity  | 240 hours at 95 % RH<br>to IEC 60068-2-3, test Ca  |   |  |
| Mass  | approx. 60 g   |   |  |

# ET-A Thermal-Magnetic Circuit Breaker 201/-WA

## Dimensions

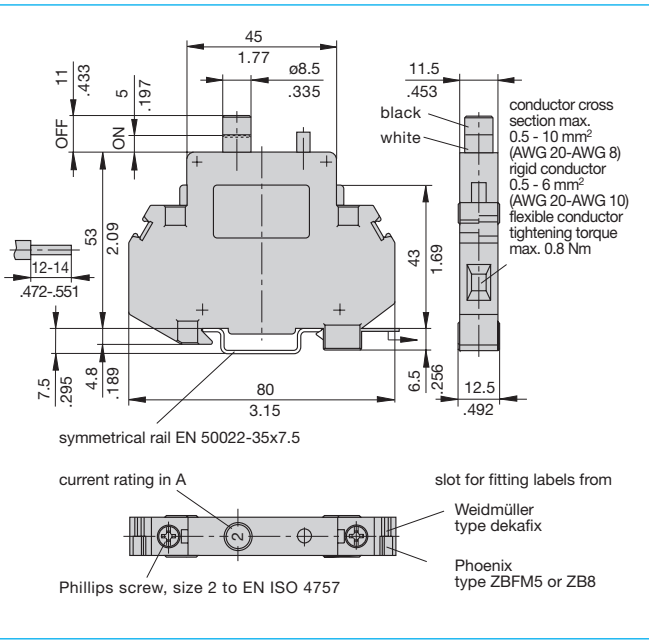

## Installation drawing

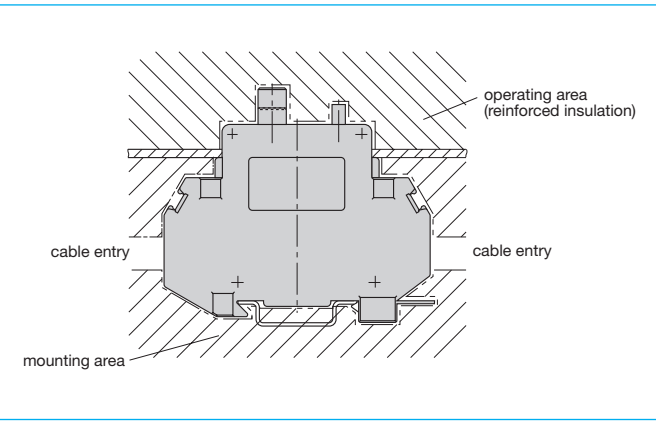

This is a metric design and millimeter dimensions take precedence ( $\frac{\text{mm}}{\text{inch}}$ )

## Internal connection diagram

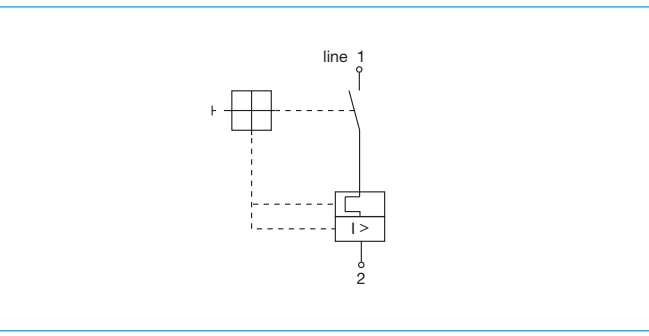

The time/current characteristic curve depends on the ambient temperature prevailing. In order to eliminate nuisance tripping, please multiply the circuit breaker current ratings by the derating factor shown below. See also section 9 – Technical information.

| Ambient temperature °F | -22  | -4   | +14  | +32  | +73.4 | +104 | +122 | +140 |
|------------------------|------|------|------|------|-------|------|------|------|
| °C                     | -30  | -20  | -10  | 0    | +23   | +40  | +50  | +60  |
| Derating factor        | 0.76 | 0.79 | 0.83 | 0.88 | 1     | 1.08 | 1.16 | 1.24 |

## Typical time/current characteristics

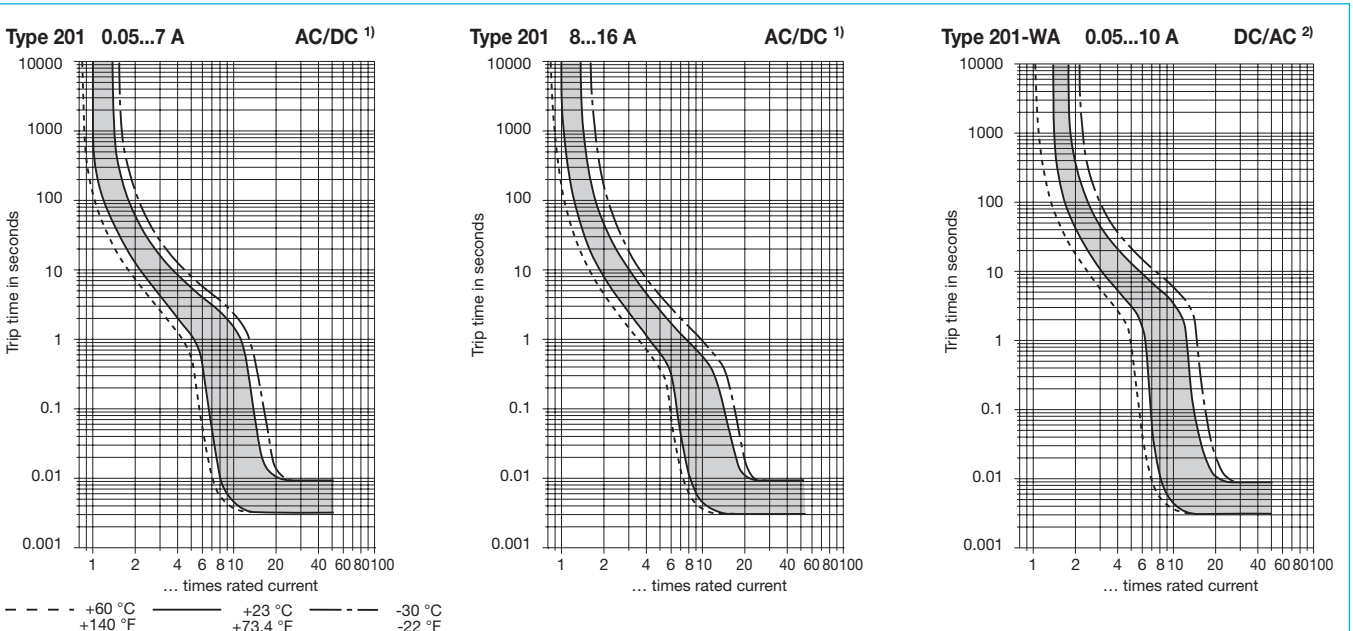

<sup>1)</sup> Magnetic tripping currents are increased by 20% on DC supplies.  
<sup>2)</sup> Magnetic tripping currents are decreased by 20% on AC supplies.

## Accessories

**Adapter** for EN rail 50035-G32 specified as a separate item  
**X 200 409 01**

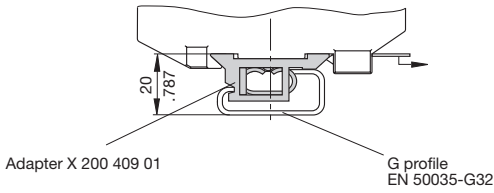

**Connector bus links -K10**

**X 210 589 01**/2.5 mm<sup>2</sup>, (AWG 14) (black) up to 20 A max. load  
**X 210 589 02**/1.5 mm<sup>2</sup>, (AWG 16) (brown) up to 13 A max. load

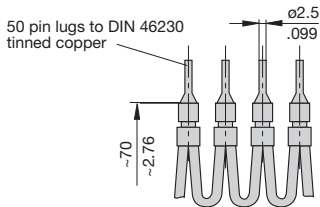

**Bus bar**

**X 221 498 01** (17-way)  
up to 70 A max. load

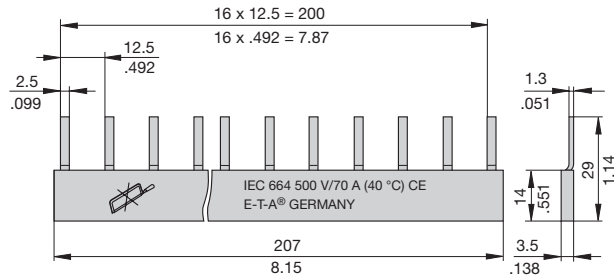

**Supply terminal for bus bar**

**X 221 496 01**  
up to 70 A max. load

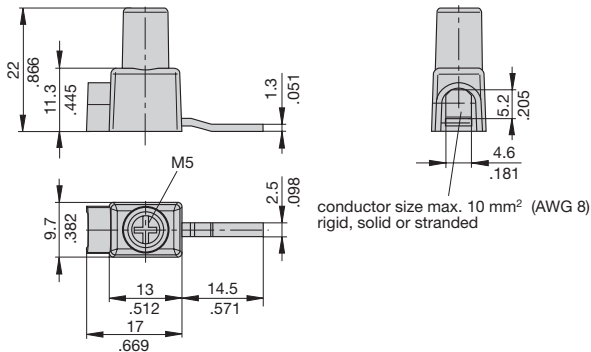

This is a metric design and millimeter dimensions take precedence ( $\frac{\text{mm}}{\text{inch}}$ )

All dimensions without tolerances are for reference only. In the interest of improved design, performance and cost effectiveness the right to make changes in these specifications without notice is reserved. Product markings may not be exactly as the ordering codes. Errors and omissions excepted.

## Description

One, two and three pole thermal-magnetic circuit breakers with trip-free mechanism and toggle actuation (S-type TM CBE to EN 60934/IEC 934). Featuring a combi-foot design for both symmetric and asymmetric rail mounting. Available with auxiliary contact (1 x N/O or 1 x N/C) for status signalling. Two and three pole models are internally linked to ensure that both/all poles trip in the event of an overload on one pole, even if the actuator is held in the ON position. This CBE can be supplied in current ratings up to 32 A with a choice of characteristic curves. All screw terminals are recessed for safety. Approved to CBE standard EN 60934 (IEC 60934).

## Typical applications

Process control equipment, robotics, machine tool control, communications systems, instrumentation.

## Ordering information

|   |   |
|---|---|
| <b>Type No.</b>   | 2210  |
|   | single and multipole thermal-magnetic circuit breaker   |
| <b>Mounting</b>   | T rail mounting   |
| <b>Actuator design</b>                                  | 2 toggle  |
| <b>Number of poles</b>                                  | 1 single pole protected<br>2 2-pole protected<br>3 3-pole protected<br>5 2-pole, protected on one pole only   |
| <b>Accessories</b>                                      | 0 without accessories   |
| <b>Terminal design (main contacts)</b>                  | K0 screw terminals  |
| <b>Characteristic curve</b>                             | F1 fast acting: therm. 1.01-1.4xI <sub>N</sub> ; magn. 2-4xI <sub>N</sub> DC (DC only)<br>F2 fast acting: therm. 1.01-1.4xI <sub>N</sub> ; magn. 3,5-6,5xI <sub>N</sub> AC/4,5-8,5xI <sub>N</sub> DC<br>M1 standard delay: therm. 1.01-1.4xI <sub>N</sub> ; magn. 6-12xI <sub>N</sub> AC, 7.8-15.6xI <sub>N</sub> DC<br>T1 delayed: therm. 1.01-1.4 I <sub>N</sub> ; magn. 10-20xI <sub>N</sub> AC<br>T2 thermal only, 1.01-1.4xI <sub>N</sub><br>M3 standard delay, low resistance: therm. 1.4-1.8xI <sub>N</sub> ; magn. 6-12xI <sub>N</sub> AC, 7.8-15.6xI <sub>N</sub> DC |
| <b>Auxiliary contact design</b>                         | H without intermediate position   |
| <b>Auxiliary contacts</b>                               | 0 without auxiliary contacts<br>1 with auxiliary contacts<br>2 auxiliary contacts on pole 1 only (multipole devices)<br>3 auxiliary contacts on pole 1 and 3 (3-pole devices)   |
| <b>Auxiliary contact function (see diagrams)</b>        | 2 1 N/O contact<br>3 1 N/C contact  |
| <b>Auxiliary contact - terminal design</b>              | 1 screw terminals   |
| <b>Current ratings</b>                                  | 0.1...32 A  |
| 2210 - T 2 1 0 - K0 M1- H 1 2 1 - 10 A ordering example |   |

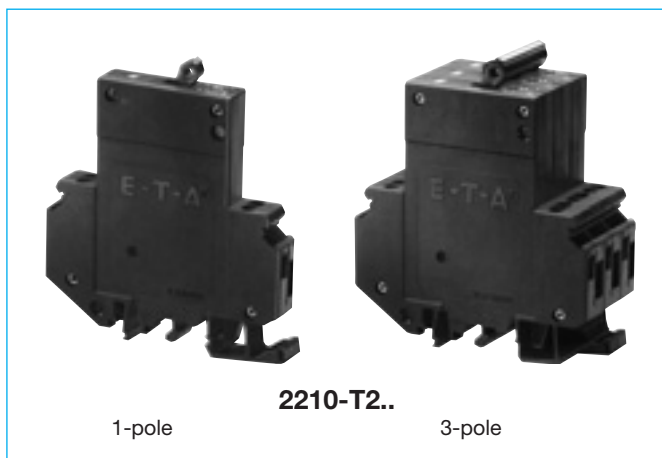

1-pole

2210-T2..

3-pole

## Technical data

For further details please see chapter: **Technical Information**

|  |  |   |
|--|--|---|
| Voltage rating                                   | AC 250 V; 3 AC 433 V (50/60 Hz); DC 65 V (UL: AC 277/480 V; DC 65 V)   |   |
| Current rating range                             | 0.1...32 A for curves M1, T1, T2<br>0.1...16 A for curves F1, F2, M3   |   |
| Auxiliary circuit                                | 1 A, AC 240 V / DC 65 V  |   |
| Typical life                                     | 3 AC 433 V; AC 250 V: 0.1...25 A<br>10,000 operations at 1 x I <sub>N</sub> , inductive<br>DC 65 V: 0.1...32 A<br>10,000 operations at 1 x I <sub>N</sub> , inductive<br>3 AC 433 V; AC 250 V: 32 A<br>10,000 operations at 1 x I <sub>N</sub> , resistive |   |
| Ambient temperature                              | -30...+60 °C (-22...+140 °F) T 60  |   |
| Insulation co-ordination (IEC 60664 and 60664 A) | rated impulse withstand voltage 2.5 kV   | pollution degree 2<br>reinforced insulation in operating area |
| Dielectric strength (IEC 60664 and 60664A)       | test voltage operating area AC 3,000 V<br>main/aux. circuit AC 3,000 V<br>pole/pole AC 1,500 V   |   |
| Insulation resistance                            | > 100 MΩ (DC 500 V)  |   |
| Interrupting capacity I <sub>cn</sub>            | 0.1...5 A 400 A;<br>curve T2 : 0.1...32 A 15 x I <sub>N</sub><br>curve M3: 0.1...2 A   | 6...32 A 800 A;<br>AC 200A / DC 400A                          |
| Interrupting capacity (UL 1077)                  | I <sub>N</sub> 0.1...16 A 20...32 A<br>1- + 2-pole AC 277 V /5,000 A AC 277 V /2,000 A<br>3-pole 3 AC 480 V /5,000 A 3 AC 480 V /2,000 A<br>1- + 2-pole DC 65 V /2,000 A DC 65 V / 2,000 A   |   |
| Degree of protection (IEC 60529/DIN 40050)       | operating area IP30<br>terminal area IP20  |   |
| Vibration  | curve F1:<br>3 g (57-500 Hz), ±0.23 mm (10-57 Hz)<br>curves M1, M3, T1, T2:<br>5 g (57-500 Hz), ±0.38 mm (10-57 Hz)<br>to IEC 60068-2-6, test Fc<br>10 frequency cycles/axis   |   |
| Shock  | curve F1:<br>25 g (11 ms), directions 1, 2, 3, 4, 5<br>10 g (11 ms), direction 6<br>curves M1, M3, T1, T2:<br>25 g (11 ms), directions 1, 2, 3, 4, 5<br>20 g (11 ms), direction 6<br>to IEC 60068-2-27, test Ea  |   |
| Corrosion  | 96 hours at 5 % salt mist<br>to IEC 60068-2-11, test Ka  |   |
| Humidity   | 240 hours at 95 % RH<br>to IEC 60068-2-3, test Ca  |   |
| Mass   | approx. 60 g per pole  |   |

## Approvals

| Authority      | Voltage ratings                                | Current ratings |
|----------------|--|-----------------|
| VDE (EN 60934) | 3 AC 433 V; AC 250 V; DC 65 V                  | 0.1...32 A      |
| BV             | 3 AC 415 V; AC 250 V; DC 65 V                  | 0.1...32 A      |
| UL, CSA        | 3 AC 480 V; AC 277 V;<br>AC 277/480 V; DC 65 V | 0.1...32 A      |

# ETA Thermal-Magnetic Circuit Breaker 2210-T2..

## Standard current ratings and typical internal resistance values

| Current rating (A) | Internal resistance (Ω)    |                                  |                         |                                      |                               |                        |
|--------------------|----------------------------|----------------------------------|-------------------------|--------------------------------------|-------------------------------|------------------------|
|                    | F1 fast acting for DC only | F2 fast acting delay for AC + DC | M1 standard for AC + DC | T1 delayed low resistance nur für AC | M3 standard delay for AC + DC | T2 thermal for AC + DC |
| 0.1                | 162                        | 162                              | 92                      | 81                                   | 42                            | 77                     |
| 0.2                | 39.3                       | 39.3                             | 26.1                    | 24.2                                 | 11.7                          | 23                     |
| 0.3                | 17.5                       | 17.5                             | 11.6                    | 10.4                                 | 5.6                           | 10.2                   |
| 0.4                | 9.2                        | 9.2                              | 6,6                     | 6.0                                  | 2.9                           | 5.7                    |
| 0.5                | 6.8                        | 6.8                              | 4,1                     | 3.9                                  | 1.75                          | 3,7                    |
| 0.6                | 4.2                        | 4.2                              | 3                       | 2.7                                  | 1.42                          | 2.6                    |
| 0.8                | 2.8                        | 2.8                              | 1.65                    | 1.53                                 | 0.75                          | 1.39                   |
| 1                  | 1.6                        | 1.6                              | 1,10                    | 0.98                                 | 0.5                           | 0.9                    |
| 1.5                | 0.78                       | 0.78                             | 0.47                    | 0.42                                 | 0.22                          | 0.36                   |
| 2                  | 0.42                       | 0.42                             | 0.28                    | 0.24                                 | 0.136                         | 0.19                   |
| 2.5                | 0.26                       | 0,26                             | 0.183                   | 0.17                                 | 0.083                         | 0.141                  |
| 3                  | 0.18                       | 0.18                             | 0.124                   | 0.12                                 | 0.057                         | 0.091                  |
| 4                  | 0.12                       | 0.12                             | 0.077                   | 0.073                                | 0.041                         | 0.051                  |
| 5                  | 0.092                      | 0.092                            | 0.063                   | 0.055                                | 0.032                         | 0.040                  |
| 6                  | 0.054                      | 0.054                            | 0.045                   | 0.039                                | 0.021                         | 0.027                  |
| 8                  | 0.025                      | 0.025                            | ≤ 0.02                  | ≤ 0.02                               | ≤ 0.02                        | ≤ 0.02                 |
| 10                 | 0.022                      | 0.02                             | ≤ 0.02                  | ≤ 0.02                               | ≤ 0.02                        | ≤ 0.02                 |
| 12                 | ≤ 0.02                     | ≤ 0.02                           | ≤ 0.02                  | ≤ 0.02                               | ≤ 0.02                        | ≤ 0.02                 |
| 16                 | ≤ 0.02                     | ≤ 0.02                           | ≤ 0.02                  | ≤ 0.02                               | ≤ 0.02                        | ≤ 0.02                 |
| 20                 | -                          | -                                | ≤ 0.02                  | ≤ 0.02                               | -                             | ≤ 0.02                 |
| 25                 | -                          | -                                | ≤ 0.02                  | ≤ 0.02                               | -                             | ≤ 0.02                 |
| 32                 | -                          | -                                | ≤ 0.02                  | ≤ 0.02                               | -                             | ≤ 0.02                 |

## Internal connection diagrams

...-H131-...

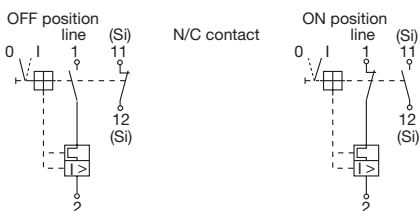

...-H121-...

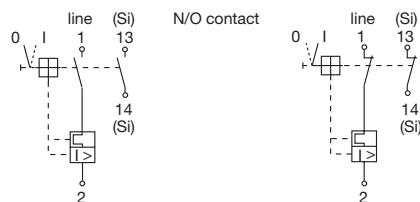

## Shock directions

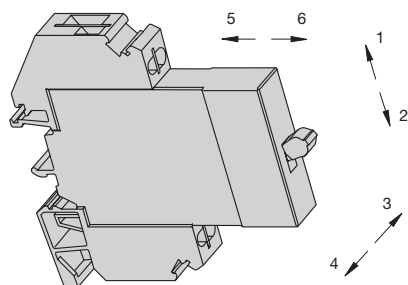

## Dimensions

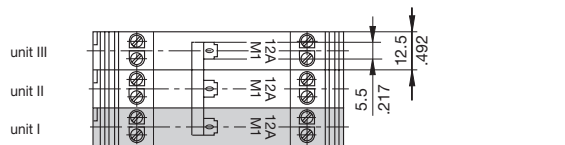
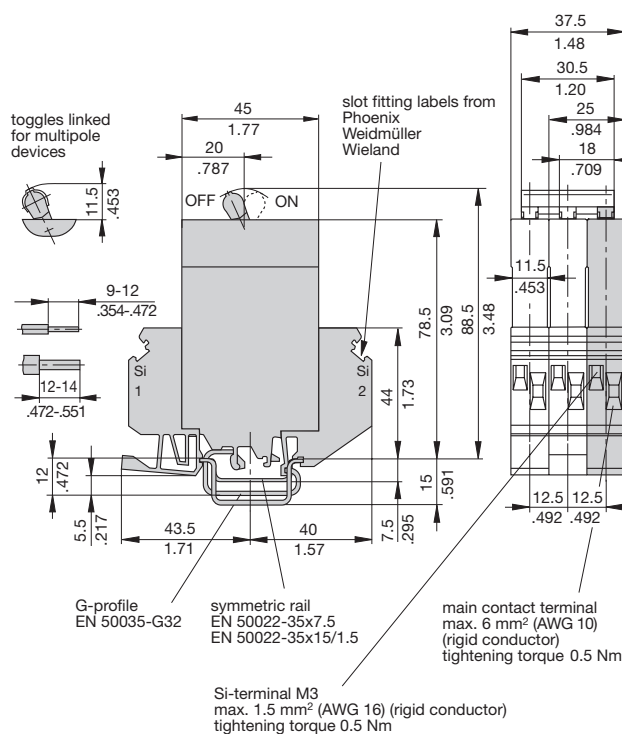

## Installation drawing

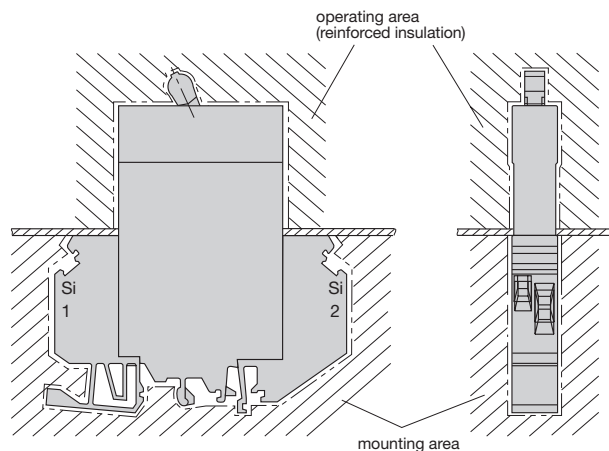

This is a metric design and millimeter dimensions take precedence (mm/inch)

## Accessories

### Connector bus links -K10

**X210 589 01**/2.5 mm<sup>2</sup>, (AWG 14) (black) up to 20 A max. load  
**X210 589 02**/1.5 mm<sup>2</sup>, (AWG 16) (brown) up to 13 A max. load

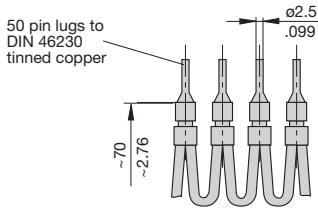

### Bus bar for 1-pole units (17-way), up to 70 A max. load **X221 498 01**

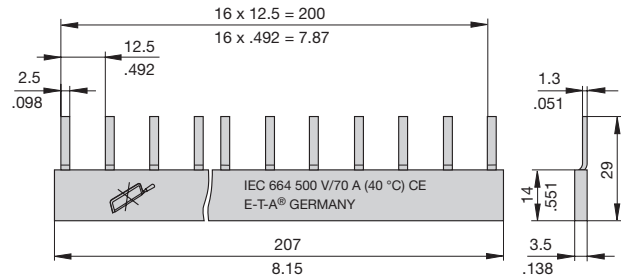

### Bus bar for 2-pole units (2 x 10-way), up to 120 A max. load **X221 497 01**

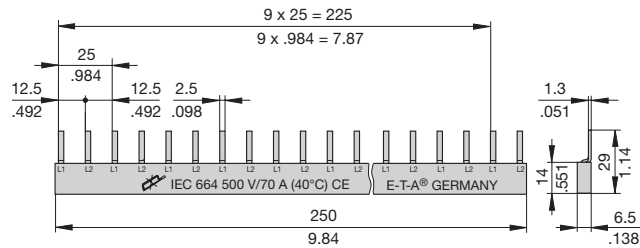

### Bus bar for 2-pole units (2 x 4-way), up to 120 A max. load **X222 002 01**

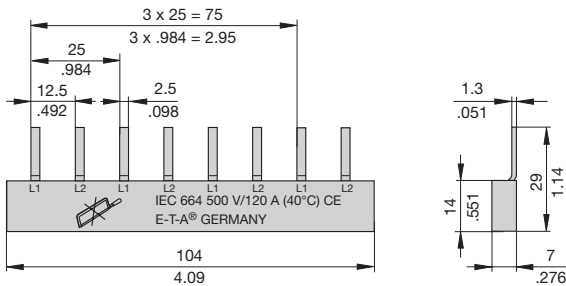

### Supply terminal for bus bar (up to 70 A max. load) **X221 496 01**

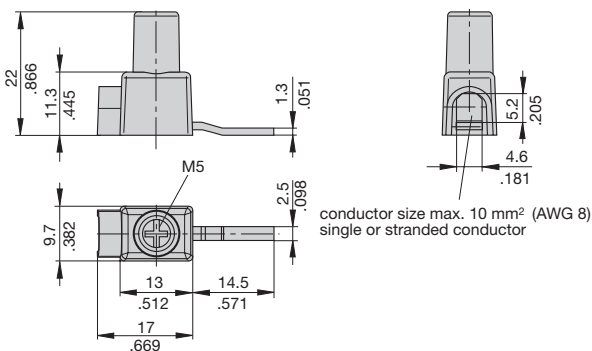

## Typical time/current characteristics

### -F1 0.1 ... 16 A

DC only

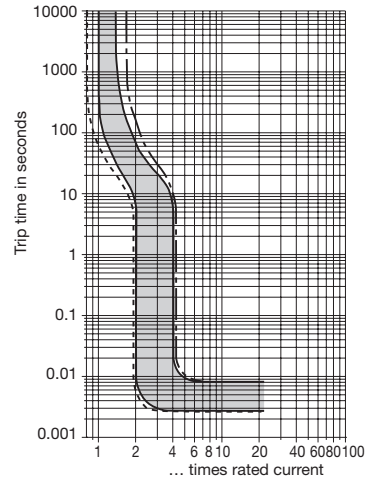

### -F2 0.1 ... 7.5 A

AC/DC <sup>1)</sup>

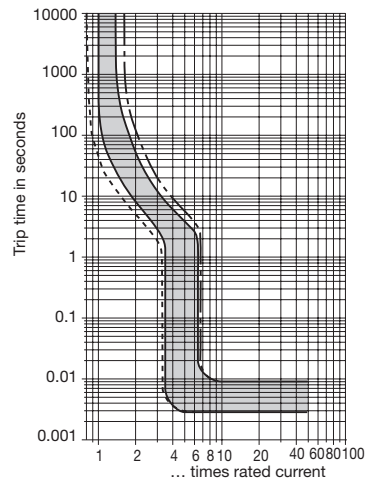

### -F2 8 ... 16 A

AC/DC <sup>1)</sup>

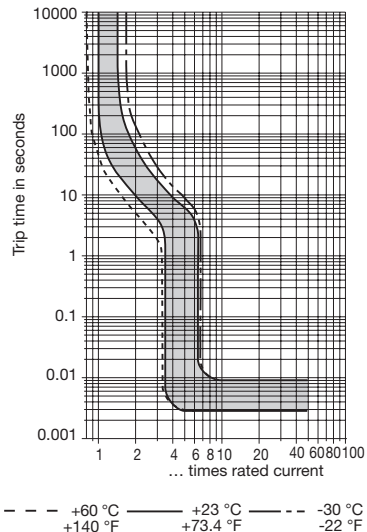

<sup>1)</sup> Magnetic tripping currents are increased by 30% on DC supplies.



# Thermal-Magnetic Circuit Breaker 2210-T2..

## Typical time/current characteristics

The time/current characteristic curve depends on the ambient temperature prevailing. In order to eliminate nuisance tripping, please multiply the circuit breaker current ratings by the derating factor shown below. See also section 9 – Technical information.

|                        |      |      |      |      |       |      |      |      |      |
|------------------------|------|------|------|------|-------|------|------|------|------|
| Ambient temperature °F | -22  | -4   | +14  | +32  | +73.4 | +86  | +104 | +122 | +140 |
| °C                     | -30  | -20  | -10  | 0    | +23   | +30  | +40  | +50  | +60  |
| Derating factor        | 0.76 | 0.79 | 0.83 | 0.88 | 1     | 1.04 | 1.11 | 1.19 | 1.29 |

Multi pole devices: all poles symmetrically loaded. With single pole overload, thermal tripping will be at max.  $1.7 \times I_N$  with curves F1, F2, M1 and T2, and at max.  $2.2 \times I_N$  with curve M3.

<sup>1)</sup> Magnetic tripping currents are increased by 30% on DC supplies.

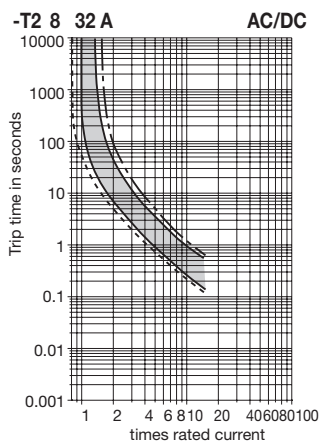
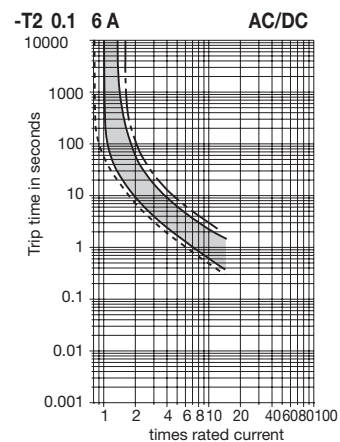
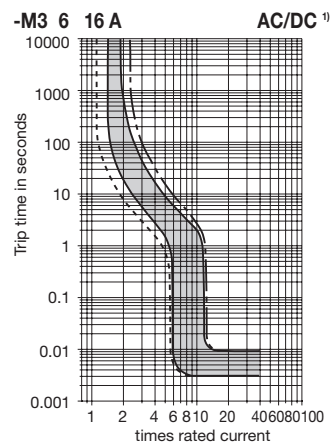
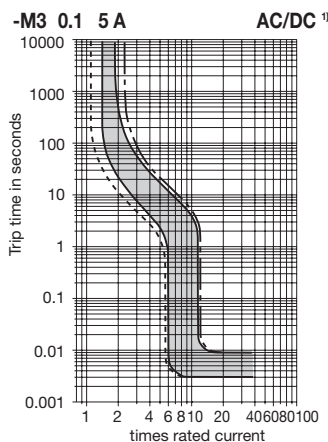
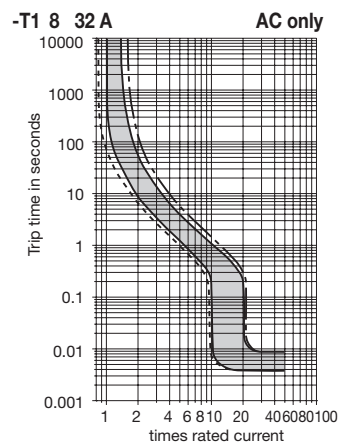
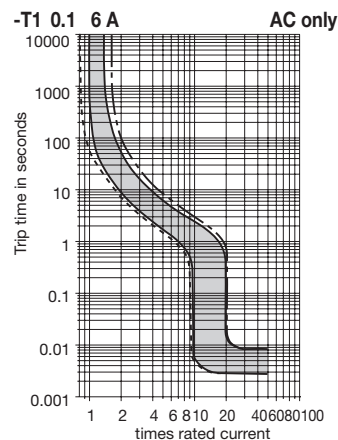
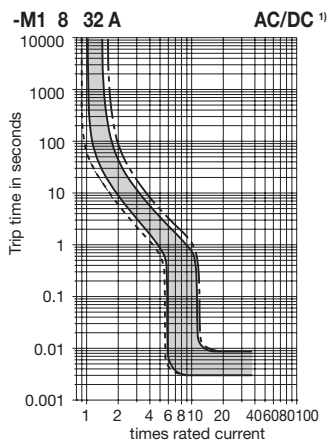
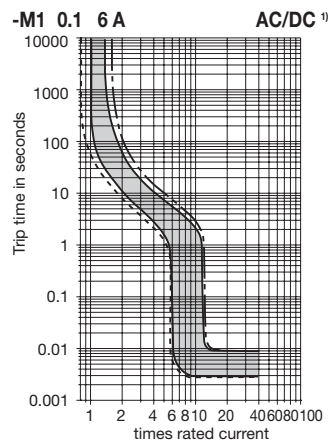

--- +60 °C    ——— +23 °C    - · - · -30 °C  
 +140 °F    +73.4 °F    -22 °F