

Dialight

RTO SERIES

LED OBSTRUCTION LIGHT



Certified to: FAA AC NO: 150/5345-43F
Canadian Aviation Regulation CAR 621.19
(Transport Canada)

Compliant to: ICAO
(Annex 14 - Fourth Edition, July 2004)
Low intensity Type A (10 cd)
Low intensity Type B (32 cd)
DGAC Mexico

FEATURES / BENEFITS

- ▲ Available as a single, dual or retro-fit unit
- ▲ Available in 120 - 277 VAC and 12 - 48 VDC
- ▲ Grounding terminals provided
- ▲ Unique optical design (patent pending)
- ▲ Advanced high-flux LED technology
- ▲ Lasts years longer than an incandescent
- ▲ Weather/corrosion resistant lamp assembly and housing
- ▲ Self-contained wiring compartment eliminates additional boxes
- ▲ Threaded 1" and 3/4" bottom hub for mounting
- ▲ Can be operated steady or flashed
- ▲ Uses 95% less energy than incandescent
- ▲ 5 year warranty
- ▲ Resistant to shock and vibration
- ▲ IP65 / IP66 / NEMA 4X

PATENTS PENDING



APPLICATION

The Dialight RTO Series obstruction light utilizes a unique optical, electrical and mechanical design. The RTO series is the most universal, compact and efficient obstruction light in the world. ETL Certified to the FAA requirements, the RTO series fixture is also ICAO and Transport Canada compliant. Also available as a single fixture for direct replacement of incandescent lamp/lens technology.

SPECIFICATIONS

- ▲ **Supply Voltage** : 100-277V, 50-60 Hz
- ▲ **Power Factor** : >0.9
- ▲ **Nominal Input Power** : 6.5W (120-240 VAC FAA version)
8.6W (120-240 VAC, Transport Canada version)
7.2W (277 VAC, FAA version)
3.5W (12-48 VDC, FAA version)
- ▲ **Operating / Storage Temperature** : -40° to +55°C

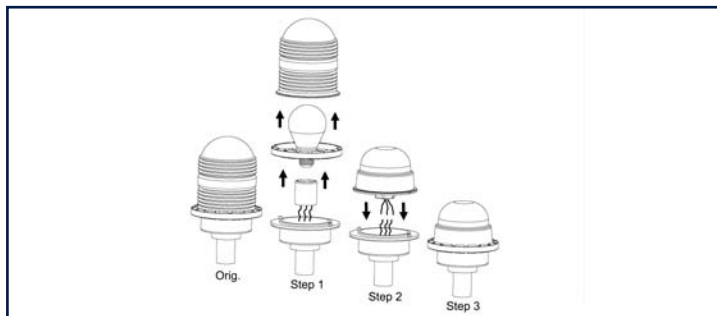

OPERATING CONDITIONS

The RTO Series is designed to withstand the dynamic conditions experienced in the most severe environments around the world. It has been tested in temperatures ranging from -40 to +55 degrees Celsius, direct sunlight, wind-blown rain, wind in excess of 150 mph, high humidity, salt and fog.

MATERIALS FINISH

- ▲ Cast Aluminum base & housing
- ▲ Aviation red UV resistant polycarbonate dome

Dialight Europe Ltd.

Exning Road, Newmarket, England, CB8 0AX
Tel: +44 (0) 1638 666541 • Fax: +44 (0) 1638 561735
www.dialight-obstruction-lights.com



A Subsidiary of Dialight PLC



Dialight Corporation

1501 Route 34 South • Farmingdale, NJ 07727 USA
Tel: (1) 732-919-3119 • Fax: (1) 732-751-5778

www.dialight.com



MDTFRTO810X001_E

PHOTOMETRIC DATA

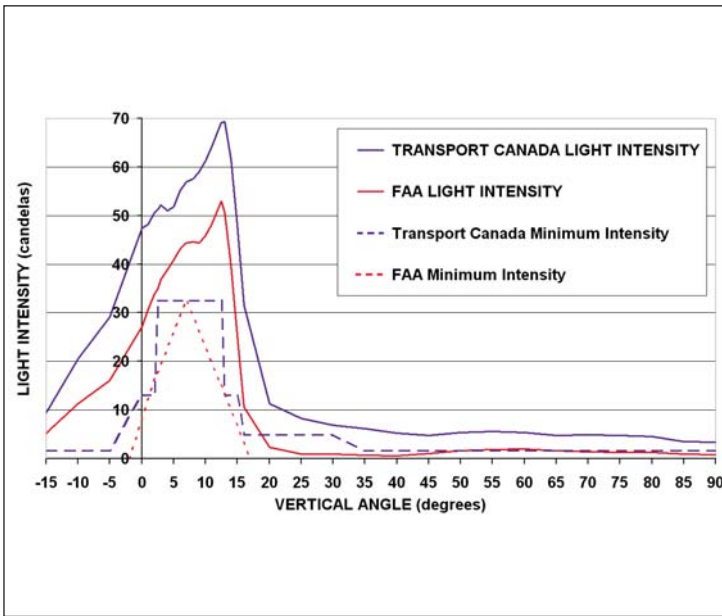

MECHANICAL DIMENSIONS

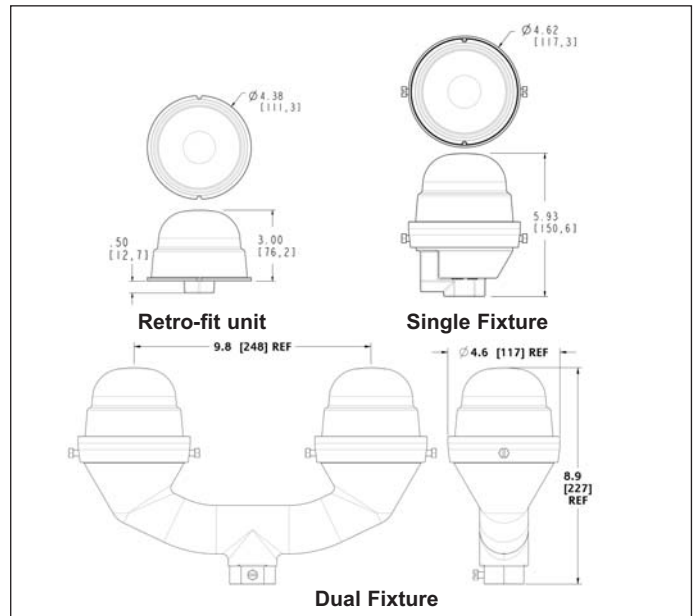

ORDERING INFORMATION

PART NUMBER	DESCRIPTION	VOLTAGE	COLOR	CERTIFICATION
RTO-1R07-001	Obstruction fixture, single	120 - 240VAC	Red	FAA
RTO-1R07-002	Obstruction fixture, double	120 - 240VAC	Red	FAA
RTO-1R07-004	Retro-fit OB fixture, single	120 - 240VAC	Red	FAA
RTO-6R07-001	Obstruction fixture, single	120 - 240VAC	Red	Transport Canada
RTO-6R07-002	Obstruction fixture, double	120 - 240VAC	Red	Transport Canada
RTO-6R07-004	Retro-fit OB fixture, single	120 - 240VAC	Red	Transport Canada
RTO-1R06-001	Obstruction fixture, single	277VAC	Red	FAA
RTO-1R06-002	Obstruction fixture, double	277VAC	Red	FAA
RTO-1R06-004	Retro-fit OB fixture, single	277VAC	Red	FAA
RTO-1R08-001	Obstruction fixture, single	12 - 48VDC	Red	FAA
RTO-1R08-002	Obstruction fixture, double	12 - 48VDC	Red	FAA
RTO-1R08-004	Retro-fit OB fixture, single	12 - 48VDC	Red	FAA

WEIGHTS & MEASUREMENTS

MODEL	SHIPPING WEIGHT	CONTAINER DIMENSIONS
Retro Unit	1.25 lbs	7.60" x 5.25" x 5.75"
Single Unit	2.00 lbs	7.60" x 5.25" x 5.75"
Dual Unit	4.60 lbs	18.6" x 12.5" x 6.40"

ELECTRICAL SPECIFICATIONS

MODEL	OPERATING VOLTAGE	VOLT-AMPS (NOMINAL)	INPUT POWER (NOMINAL)
FAA	100-240 VAC +/- 10%	6.8 VA	6.5 W
Transport Canada	100-240 VAC +/- 10%	9.0 VA	8.6 W
FAA	277 VAC +10% -30%	7.2 VA	6.8 W
FAA	12-48 VDC	-	3.3 W

Dialight Europe Ltd.

Exning Road, Newmarket, England, CB8 0AX

Tel: +44 (0) 1638 666541 • Fax: +44 (0) 1638 561735

www.dialight-obstruction-lights.com



A Subsidiary of Dialight PLC



Dialight Corporation

1501 Route 34 South • Farmingdale, NJ 07727 USA

Tel: (1) 732-919-3119 • Fax: (1) 732-751-5778

www.dialight.com



MDTFRTO810X001_E