

Description

Single pole, miniaturised aircraft simulator switch with extremely fast magnetic trip time. Blade, screw and wire wrap terminals. Aircraft style threadneck and push/pull button with white trip indicator ring. Current rating marked on the push button according to customer's request by adhesive labels or marking inserts.

Typical applications

Simulators.

Ordering information

Type No.	
9510	switch with magnetic instantaneous trip for flight simulators
Mounting method and style	
G	threadneck mounting with standard push button
L	threadneck mounting with long push button
Threadneck design	
1	M12x1x6.3
2	7/16-32UNx6.3
Number of poles	
1	single pole
Accessories for threadneck	
0	without accessories
1	hex nut M12x1, aluminium, lock washer $\phi 12 / \phi 15$ (crinkle) fitted
2	hex nut M12x1, aluminium, serrated lock washer $\phi 12.1 / \phi 17.2$, fitted
3	hex nut 7/16-32UN, aluminium, toothed washer $\phi 11.3 / \phi 14.9$, fitted (MS 3533-141)
9	front plate with mounting thread 6-32UNC-2B for threadneck 7/16-32 UN, threaded sleeve 7/16-32 UN
Terminal configuration	
J	screw terminals with inch thread
1	6-32UNC-2B, silver plated bent 45° inwards
3	6-32UNC-2B, silver plated, with socket, bent 45° inwards
P	blade terminals
1	A6.3x0.8 DIN 46244, silver plated
W	wire wrap terminal
4	pin size 1.2x1.2 EN 60352-1, gold plated, with socket
Z	0 without terminals
Rated voltage	
F0	DC 24 V
F1	DC 28 V
F2	DC 48 V
F4	DC 12 V
Accessories (terminal screws)	
B	Phillips screw 6-32UNC-2Ax4.8 fitted (MS 51957-25)
Z	without accessories
Accessories (terminal washers)	
0	without accessories
2	3.6 split washer fitted (MS 35338-136)
Internal circuit	
R2	with logic diode, contacts gold plated
Colour of the push button	
S	black
G	green
A	green, for marking insert
B	black, for marking insert
0	without marking
1	hot-stamped marking, can be read when locating pin is above
2	hot-stamped marking, can be read when locating pin is at the bottom
9	without marking insert
Current ratings	
0.5...150 A	
9510 - G 1 1 1 - J 1 F1 - B 0 R2 S 0 - 10 A ordering example	



Technical data

Voltage rating	DC 12 V	DC 24 V	DC 28 V	DC 48 V
Trip current	< 450 mA	< 160 mA	< 200 mA	< 340 mA
Trip time	< 25 ms	< 25 ms	< 25 ms	< 20 ms
Min. switching voltage	at +23 °C/+73.4 °F		DC 25 V	
	at +60 °C/+140 °F		DC 28 V	
Internal resistance	157 Ω			
Typical life	10,000 operations at DC 24, 28 or 48 V			
Temperature range	-30...+60 °C (-22...+140 °F)			
Insulation resistance	> 100 M Ω (DC 500 V)			
Degree of protection (IEC 60529)	operating area IP40 terminal area IP00			
Vibration (sinusoidal)	3 g (57-500 Hz), \pm 0.23 mm (10-57 Hz) to DIN IEC 60068-2-6, test Fc 10 cycles/frequency axis			
Shock	5 g (11 ms), to DIN IEC 60068-2-27, test Ea			
Humidity	240 hours at 95 % RH, 40°C to DIN IEC 60068-2-3, test Ca			
Mass	23 g without hardware 26 g with hardware			

Dimensions

9510-G...-J1..-B2....

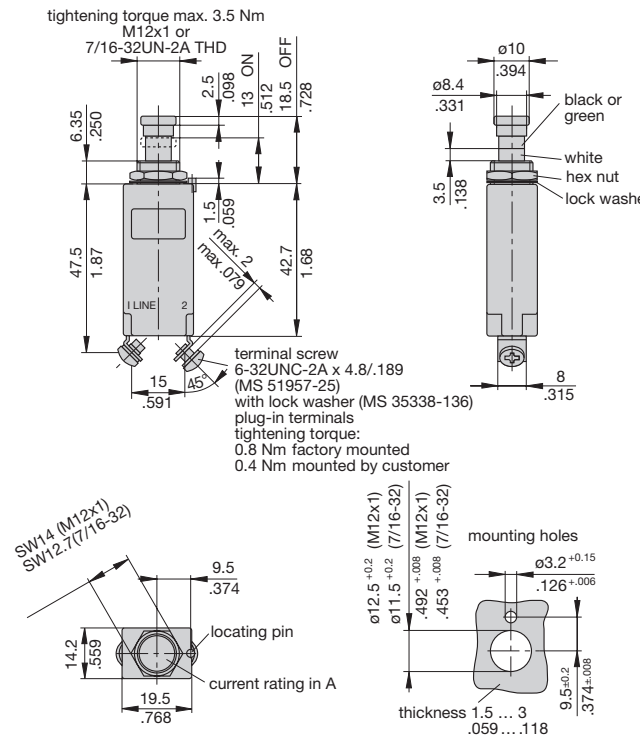

Other main terminal designs

-P1...

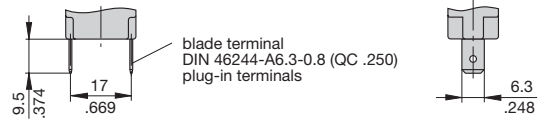

-J3...

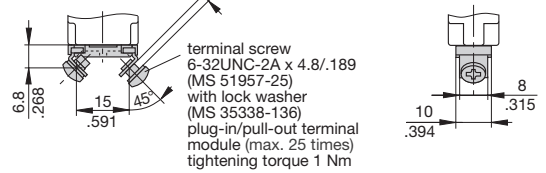

-W4...

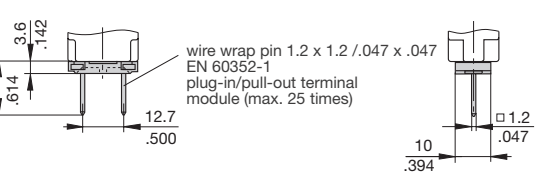

Internal connection diagram

internal circuit R 2

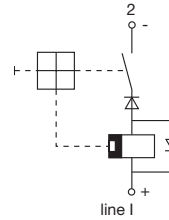

Other threadneck designs

-L...

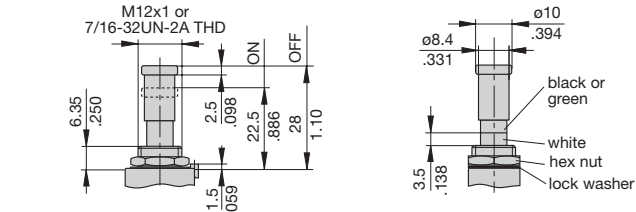

-G219 -L219

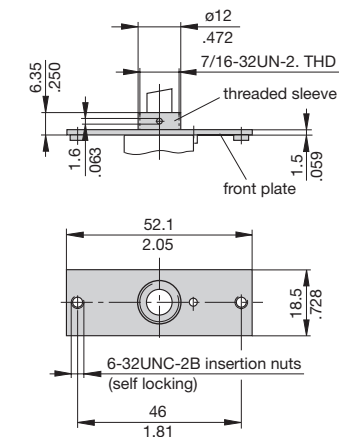

Accessories

Label (black) for push/pull button (S0 or G0)

Part number	Rated current (A)
Y 307 082 01	0.5
Y 307 082 02	1/2
Y 307 082 03	1
Y 307 082 04	1.5
Y 307 082 05	1 1/2
Y 307 082 06	2
Y 307 082 07	3
Y 307 082 08	5
Y 307 082 09	7.5
Y 307 082 10	7 1/2
Y 307 082 11	10
Y 307 082 12	15
Y 307 082 13	20
Y 307 082 14	25
Y 307 082 15	30
Y 307 082 16	35
Y 307 082 17	6
Y 307 082 18	40
Y 307 082 19	50
Y 307 082 20	60
Y 307 082 21	70
Y 307 082 22	75
Y 307 082 23	80
Y 307 082 24	90
Y 307 082 25	100
Y 307 082 26	120
Y 307 082 27	125
Y 307 082 28	150
Y 307 082 29	2.5
Y 307 082 30	2 1/2
Y 307 082 31	7

Plug-in screw terminal,

bent at 45° inwards (2 pcs needed per unit)

Y 307 187 02 terminal silver plated

Y 304 508 02 Phillips screw 6-32 UNC-2Ax4.8 (MS 51957-25)

Y 304 509 01 split washer (MS 35338-36)

Plug-in blade terminal (2 pcs needed per unit)

Y 307 202 02 P10 terminal silver plated

Plug-in/pull-out screw terminals with socket,

bent at 45° inwards

X 222 173 11 terminals silver plated

Plug-in/pull-out wire wrap terminals with socket

X 222 174 12 terminals gold plated

Splash cover/hex nut assembly with O ring (IP66)

(approved to VG 95345, part 23)

X 200 801 03 matt black finish nut M12x1x1.8, black cover

X 200 801 08 nickel plated nut M12x1x1.8, transparent cover

X 200 801 09 matt black finish nut 7/16-32x1x1.8, black cover

X 200 801 10 matt black finish nut 7/16-32x1x1.8, transparent cover

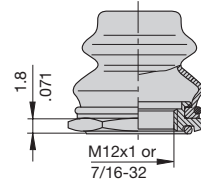

Actuator extension (black) to be fitted on the push button

(approved to VG 95345, T23)

X 200 803 01

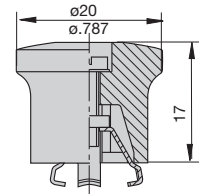

Identification collar to be snapped on the push button

Y 307 004 01 black

Y 307 004 02 white

Y 307 004 03 red

Y 307 004 04 green

Y 307 004 05 blue

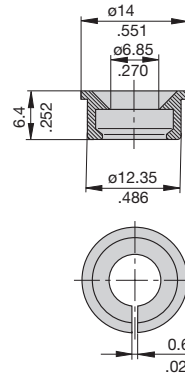

Lock out ring to block the push button in OFF position

Y 307 005 01 red

Y 307 005 02 black

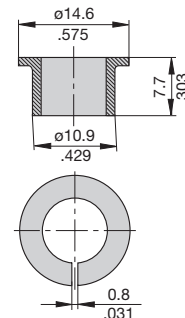

Accessories

Hex nut M12x1
Y 300 116 04

Hex nut 7/16-32
Y 304 506 03

Lock washer Ø12 / Ø15
Y 300 118 03

Serrated lock washer Ø12.1 / Ø17.2
Y 302 911 01

Toothed washer Ø11.3 / Ø14.9 (MS 35333-141)
Y 304 507 01

**Front plate with mounting thread 6-32 UNC-2B
for threadneck 7/16-32 UN**
Y 301 516 21

Threaded sleeve
Y 307 281 02

Extracting tool of marking insert
Y 307 301 01

Marking inserts (push button configuration A or B)

hot stamped black	green	current rating (A)
Y 307 280 01	Y 307 280 02	without
X 222 175 01	X 222 176 01	0.5
X 222 175 02	X 222 176 02	1/2
X 222 175 03	X 222 176 03	1
X 222 175 04	X 222 176 04	1.5
X 222 175 05	X 222 176 05	1 1/2
X 222 175 06	X 222 176 06	2
X 222 175 07	X 222 176 07	3
X 222 175 08	X 222 176 08	5
X 222 175 09	X 222 176 09	7.5
X 222 175 10	X 222 176 10	7 1/2
X 222 175 11	X 222 176 11	10
X 222 175 12	X 222 176 12	15
X 222 175 13	X 222 176 13	20
X 222 175 14	X 222 176 14	25
X 222 175 15	X 222 176 15	30
X 222 175 16	X 222 176 16	35
X 222 175 17	X 222 176 17	6
X 222 175 18	X 222 176 18	40
X 222 175 19	X 222 176 19	50
X 222 175 20	X 222 176 20	60
X 222 175 21	X 222 176 21	70
X 222 175 22	X 222 176 22	75
X 222 175 23	X 222 176 23	80
X 222 175 24	X 222 176 24	90
X 222 175 25	X 222 176 25	100
X 222 175 26	X 222 176 26	120
X 222 175 27	X 222 176 27	125
X 222 175 28	X 222 176 28	150
X 222 175 29	X 222 176 29	2.5
X 222 175 30	X 222 176 30	2 1/2
X 222 175 31	X 222 176 31	7

All dimensions without tolerances are for reference only. In the interest of improved design, performance and cost effectiveness the right to make changes in these specifications without notice is reserved. Product markings may not be exactly as the ordering codes. Errors and omissions excepted.

Description

The BMS01 is a battery master switch designed for dangerous goods road vehicles complying with international ADR regulations. Environmental protection and the intrinsically safe control circuitry of the BMS01 are in accordance with ADR 2005. The battery switch must be installed between the battery and the vehicle's electrical system. It is operated on and off by means of a control switch in the driver's cab, additional control switches can be sited around the vehicle as required. The BMS01 is available in single pole and double pole versions. An integral safety barrier permits siting of the BMS01 in hazardous areas. Additional auxiliary contacts are provided for disconnection of the ignition circuit, de-energisation of the alternator field winding, or a controlled shutdown of the CANBUS system followed after a delay by disconnection of the battery.

Typical applications

Utility vehicles for hazardous goods.

Ordering information

Type number

BMS01 Battery Master Switch (to ADR 2005)

Number of poles

2 max. 2-pole (for 1-pole please see connection diagram)

Rated voltage

0 DC 12 V

1 DC 24 V

Control function: delay time between auxiliary contact K13 and main contacts

1 1 sec

2 9.5 sec

Control function: low voltage monitoring

0 without

1 with low voltage monitoring function

Version

0 neutral

BMS01-2 - 1 - 2 - 1 - 0 ordering example

Accessories (e.g. ADR control switch, 7-pole and 4-pole connectors) should be ordered separately.

Approvals

(e1)	EC directive 72/245/EWG
(CE)	EMC directive 89/336/EWG
(ATEX)	EC directive 94/9

Protection Class

IP69K

NEW



BMS01

Technical data

Operating data

Voltage rating	DC 24 V	DC 12 V
Voltage range	18...32 V	9...16 V
Rated current	200 A	
Max. overload current	2,400 A 1 s, 600 A 20 s	
Quiescent load electronic module	≤ 5 mA	
Current required to operate	typically 1 A / for 50 ms	
Control circuit (EX)	ZELM 04 ATEX 0213X Ex II (2) G [EEx ib] II C	
Temperature range	-40...+70 °C (-40...+158 °F)	
Reverse polarity protection	integral (in the event of reverse polarity the master switch will disconnect instantaneously)	
Low voltage monitoring	switching thresholds: 22.8 V ± 0.3 V hysteresis: typically 0.5 V trip time: typically 60 sec	
Typical life	10,000 cycles at rated current 100,000 cycles mechanically	
Protection class: housing	IP69k	
Protection class: terminals	IP54 terminal stud with moulded cover	
Vibration	5 g (57-200 Hz), ±0.38mm (10-57 Hz), test to IEC 60068-2-6, test Fc, 10 frequency cycles / axis	
Shock	10 g, test to IEC 60068-2-27, test Ea	
Corrosion	96 hrs 5% salt mist, test to IEC 60068-2-11, test Ka	
Humidity	240 hrs. 95% RH, test to IEC 60068-2-3, test Ca	
Terminals	battery terminals: M10 terminal studs control terminals: AUX connectors to DIN 72 585, 7-pole CRTL connectors to DIN 72 585, 2-pole	
Auxiliary contact	max. 10 A (circuit unprotected)	
Mass	approx. 1,700 g	

Dimensions

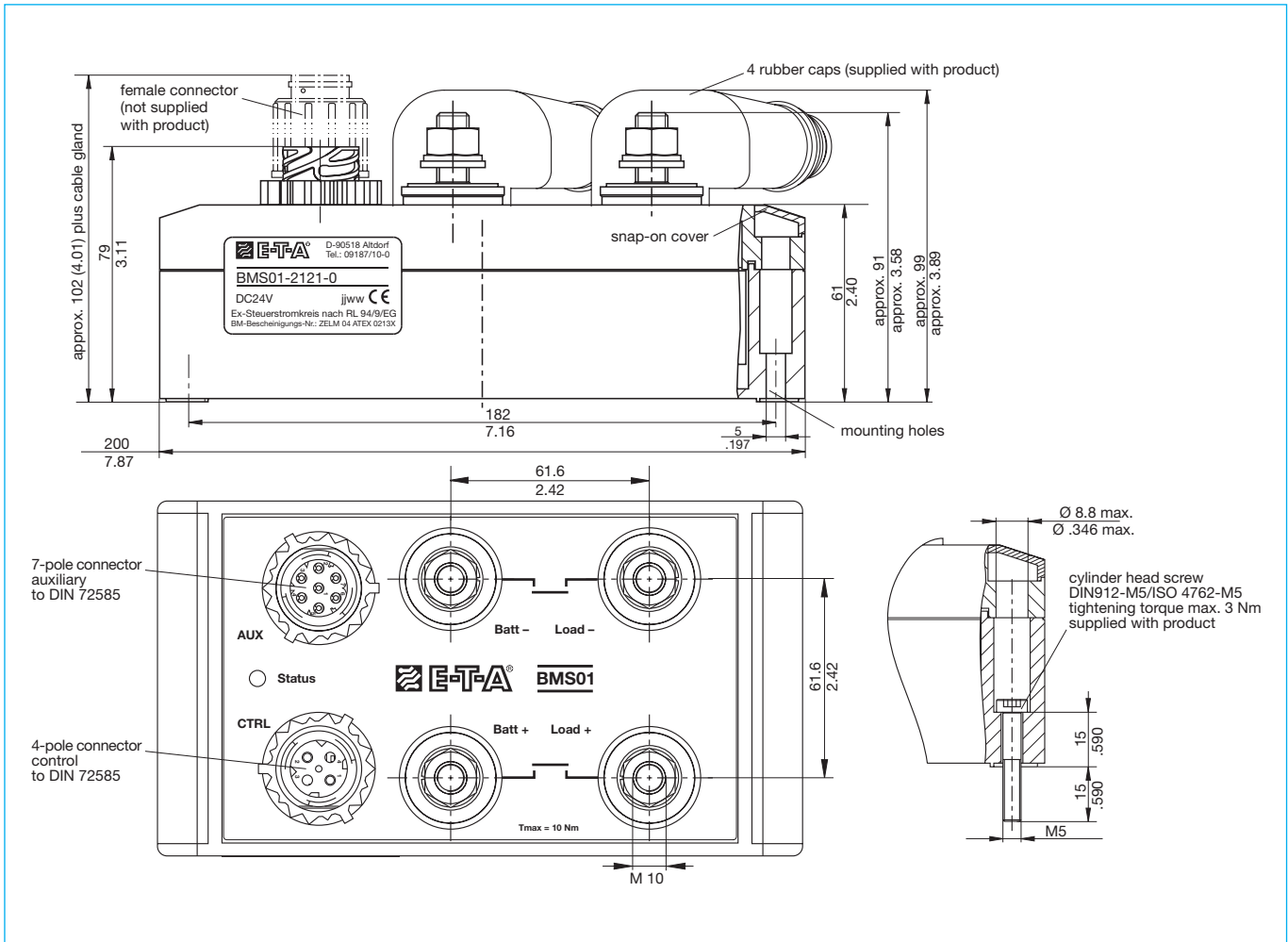

This is a metric design and millimeter dimensions take precedence ($\frac{mm}{inch}$)

Connection diagram 1-pole

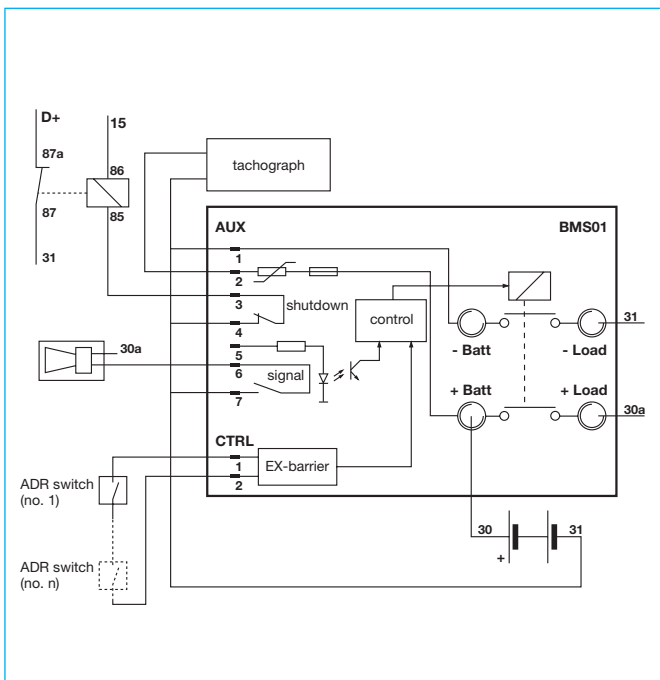

Connection diagram 2-pole

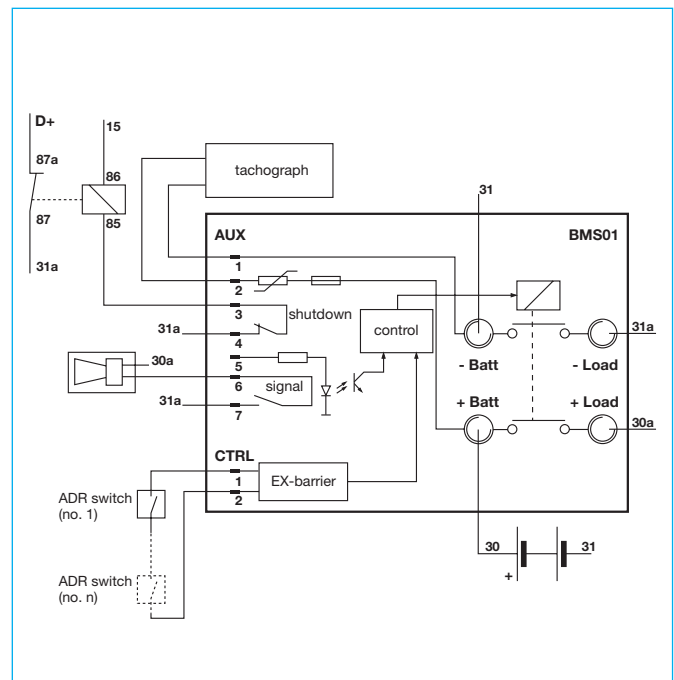

Terminal design

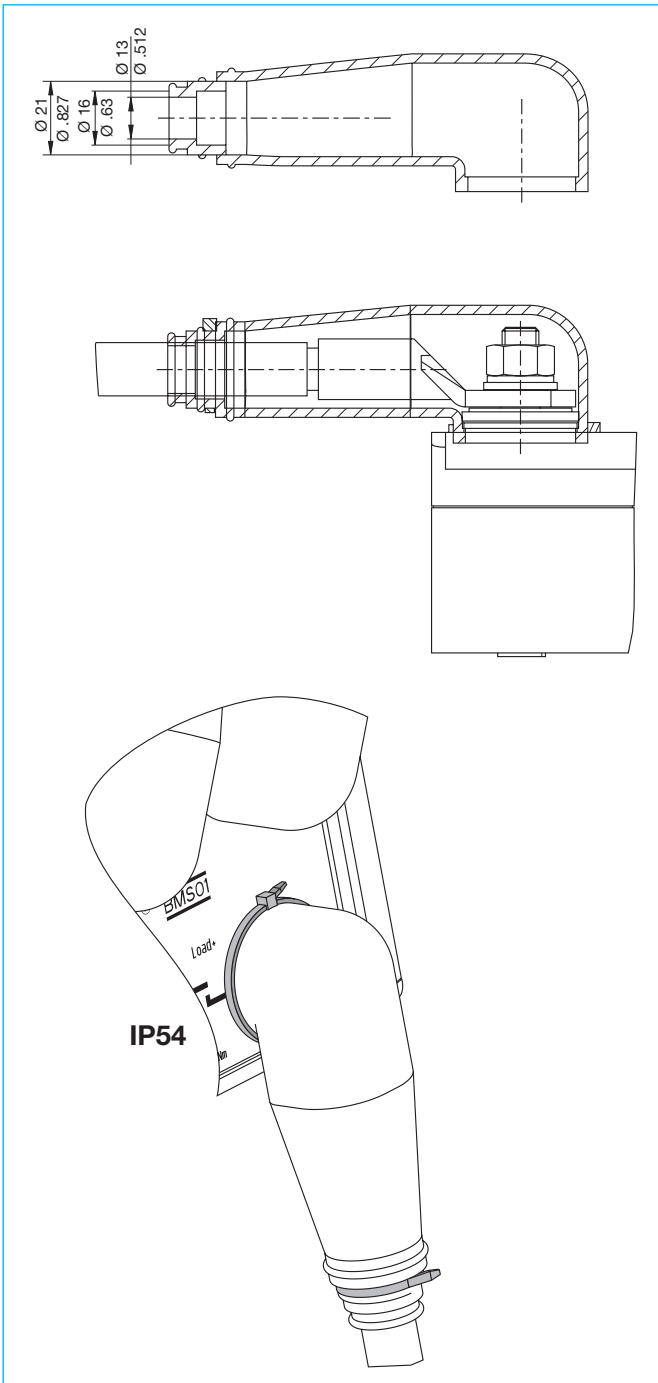

This is a metric design and millimeter dimensions take precedence ($\frac{\text{mm}}{\text{inch}}$)

All dimensions without tolerances are for reference only. In the interest of improved design, performance and cost effectiveness the right to make changes in these specifications without notice is reserved. Product markings may not be exactly as the ordering codes. Errors and omissions excepted.

Description

For vehicles carrying dangerous goods the European guideline ADR (European agreement concerning the international carriage of dangerous goods by road) requires the installation of a battery switch capable of being operated and reset from the driver's position.

E-T-A series E-1032 switches provide electrically controlled on and off operation to meet this requirement. They are also fitted within an IP65 housing which, in accordance with ADR provision 220511, will ensure that operation of the switch in an explosive atmosphere will not constitute a fire hazard. The permanently energised connections to the switch are intrinsically safe.

Typical applications

Commercial vehicles carrying dangerous goods

Ordering information

Type No.	
E-1032	
Version	
NA1	single pole
NA2	double pole
Enclosure	
C	with moulded enclosure IP65 (GGVS/ADR)
Isolation switch	
921	single pole switch
922	double pole switch
Voltage rating	
DC 24 V	
DC 12 V	
Variant No.	
e.g. special versions, mounting plate. Designation determined by manufacturer	
E-1032 - NA1 - C 921 - DC 24 V - ... ordering example	

Approvals

Authority	Requirement	Approval mark No.
TÜV	Appendix B2 of ADR DIN/EN 40050	TÜ.EGG.030-97

Technical data

Auxiliary contact for auxiliary relay	max. 6 A (circuit not protected)
Mass	single pole: approx. 3,500 g with enclosure, double pole: approx. 3,700 g with enclosure,



E-1032

Technical data

Voltage rating	DC 24 V	DC 12 V
Voltage rang	ON 18-32 V	9-16 V
	OFF 15-32 V	8.5-16 V
The switching function is no longer ensured when the voltage falls below the minimum values. The switch will not change its position when the voltage falls down to 0 V (automatic locking).		
Current ratings	240 A single pole 120 A double pole	
Overload capacity	2,500 A for 1 s at 23 °C, single pole 1,500 A for 1 s at 23 °C, double pole	
Current consumption of the electronics	≤ 15 mA (with the control circuit connected)	
Switching current at U _N	DC 24 V:	DC 12 V:
	ON approx. 15A/100 ms OFF approx. 12A/100 ms	approx. 20A/100 ms approx. 10A/100 ms
Control circuit (Ex) (PTB No.III B/E-29861S)	4 - 6 mA ON, rated to VDE 0171, protection (Ex) G5 „intrinsically safe“	
Control switch (accessory)	with coding resistance DC 24 V: 1 kΩ DC 12 V: 330 Ω without coding resistance to ADR for external actuation	
Temperature range	-40...+75 °C (-40...+167 °F)	
Reverse polarity protection	If polarized incorrectly, the Master Switch will switch off immediately, disconnecting the entire vehicle electrical system. After approx. 30 s the circuit breaker of the ON coil will trip.	
Resetability	When the Battery Master Switch is mechanically switched off, it will be reset immediately by the electronics.	
Typical life	10,000 operations at I _N 20,000 operations, mechanical	
Degree of protection IEC 60529/DIN40050)	housing IP65 terminal studs with rubber cap IP54	
Vibration	5 g (57-200 Hz), ±0.38 mm (10-57 Hz) to IEC 60068-2-6, test Fc, 10 frequency cycles/axis	
Shock	25 g (11 ms) direction 1, 2, 3, 4 15 g (11 ms) direction 5, 6 to IEC 60068-2-27, test Ea	
Corrosion	96 h at 5 % salt mist, to IEC 60068-2-11, test Ka	
Humidity	240 h at 95 % RH, to IEC 60068-2-3, test Ca	
Terminals	Main terminals	blade terminals with cable lugs for M10 terminal studs
	Control cable	connector to DIN 72 585

Dimensions

E-1032-NA1-... 1 pole

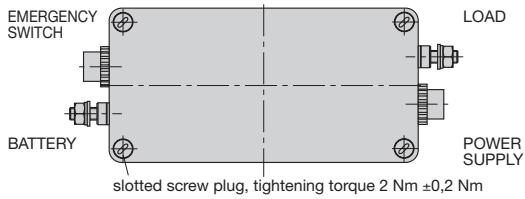
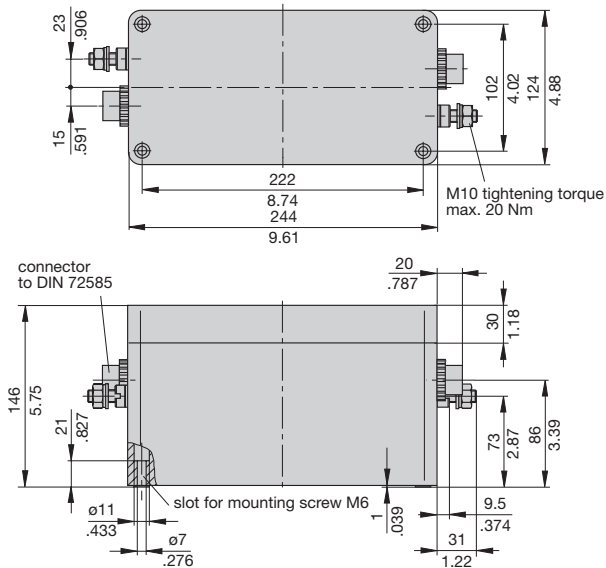

E-1032-NA2-... 2 pole

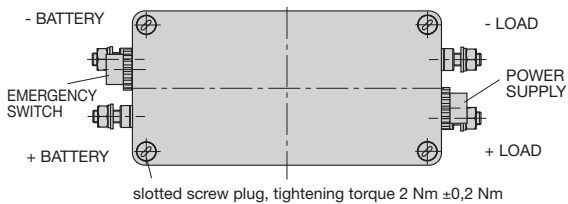
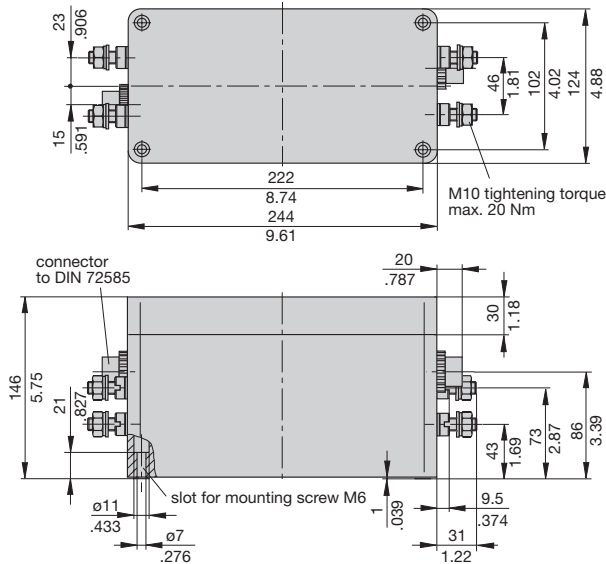

Rubber cap

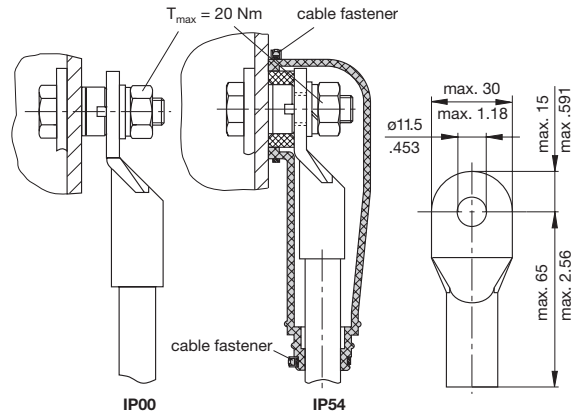

Rubber caps and cable fasteners are supplied with the product.

Internal connection diagrams

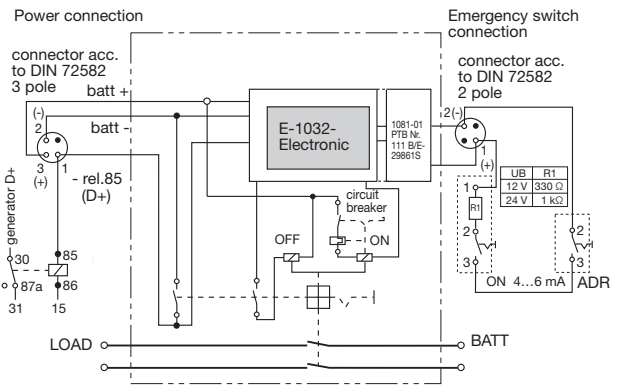

Shock directions

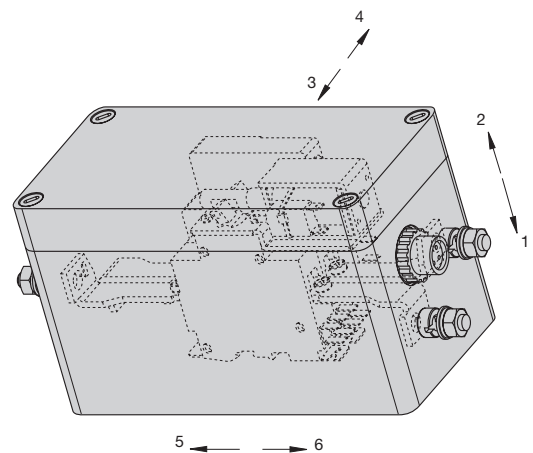

Please follow the instructions for installation

This is a metric design and millimeter dimensions take precedence ($\frac{\text{mm}}{\text{inch}}$)

Accessories

ADR switch with safety cover
OZ223Z000141 12 V
OZ223Z000142 24 V

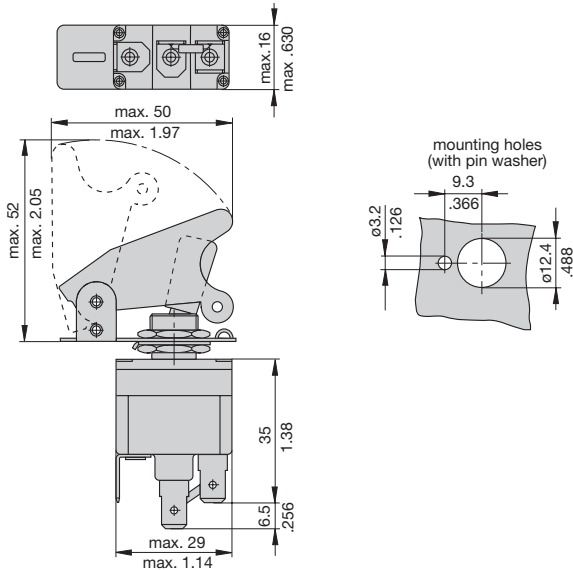

ADR switch without rubber boot
OZ223Z000143

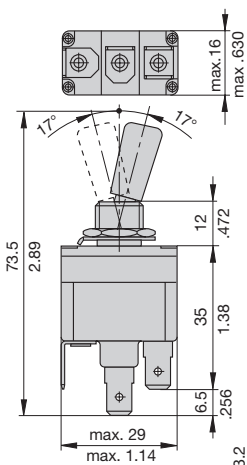

ADR switch with rubber boot
(IP54 in operating area)
OZ223Z000144

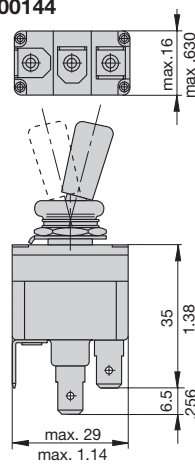

Standard connector set OZ112Z000179, comprising:

(AMP-parts) suitable for single/double pole Battery Master Switch E-1032-..., DC 12 V and DC 24 V

Quantity	Designation	Ref. No.
1	female connector, 3-pole	X 221 378 01
1	female connector, 2-pole	X 221 378 02
5+1 replacem.	jack for female connector	Y 306 501 01
5+1 replacem.	seal	Y 306 502 01
2	90° cover corrugated conduit NW 10	Y 306 499 01

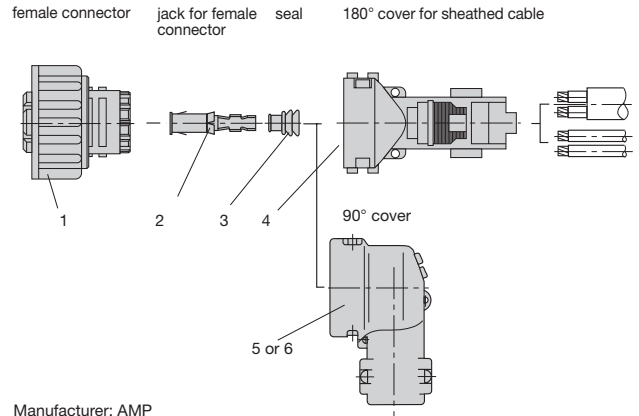

Manufacturer: AMP

- 1. Female connector SW**
X 221 378 02 2-way
X 221 378 01 3-way
X 221 378 03 4-way

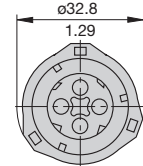
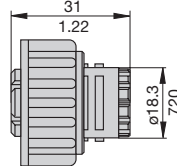

- 2. Jack for female connector**
Y 306 501 01

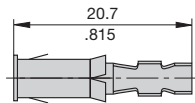

- 3. Seal**
Y 306 502 01

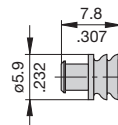

- 4. 180° cover for sheathed cable**
Y 306 500 01

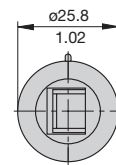
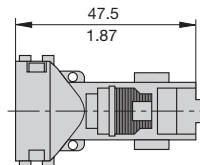

- 5. 90° cover for corrugated conduit NW10**
Y 306 499 01

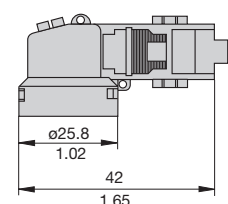
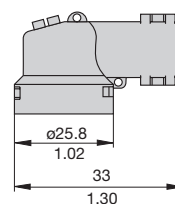
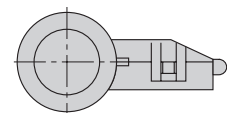
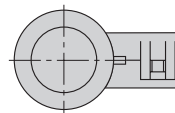

This is a metric design and millimeter dimensions take precedence ($\frac{\text{mm}}{\text{inch}}$)

All dimensions without tolerances are for reference only. In the interest of improved design, performance and cost effectiveness the right to make changes in these specifications without notice is reserved. Product markings may not be exactly as the ordering codes. Errors and omissions excepted.

Description

Single pole circuit breaker type 437 or single/two pole isolation switches types 921/922 featuring an additional electronic function module which limits the duration of the supply to the remote disconnect and reconnect coils, avoiding damage in the event of unusual operating circumstances. Available with undervoltage monitoring option to protect batteries from the effects of deep discharge, status output for undervoltage, auto reset feature.

Typical applications

Battery and cable protection for all types of vehicle (including electric), battery powered systems.

Ordering information

Type No.	
E-1073	control unit for types 921/922 and 437 with remote control
Voltage rating	
0	DC 12 V
1	DC 24 V
Control mode	
1	ON/OFF control input
00	without additional function
02	with undervoltage protection and status output
12	with autoreset, undervoltage protection and status output (921/922 only)
2	ON and OFF buttons
33	with control current supply and ON/OFF test input
Circuit Breaker/Isolation Switch	
437	single pole circuit breaker (2-pole upon request)
921	single pole battery isolation switch
922	double pole battery isolation switch
Enclosure design (optional)	
	blank = without housing
B3	moulded housing, for use with single pole devices
B32	moulded housing, for use with double pole device
B34	moulded housing, external operating knob, for use with double pole devices (not with auto reset)
B35	moulded housing, external operating knob, for use with single pole devices (not with auto reset)
Terminal design	
K12	flat screw terminals angled 90°, for single pole version
K60	straight flat screw terminals, for single pole version, without housing
K72	flat screw terminals angled 90°, for double pole version
Characteristic curve (type 437 only)	
06	fast magnetic trip
07	delayed magnetic trip (standard)
Auxiliary contacts	
Si01	one N/C, two N/O (one N/C, one N/O with autoreset option)
Current ratings	
437:	40, 50, 63, 80, 100, 120, 160, 200, 240A
921:	240 A
922:	120 A
E-1073 - 1 1 02 - 437 - B3 - K12 - 07 - Si01 - 240 A	ordering example

The exact part number required can be built up from the table of choices shown above. Ordering references for optional features should be omitted if not required.

Technical data of switch or circuit breaker

see types 437, 921 or 922

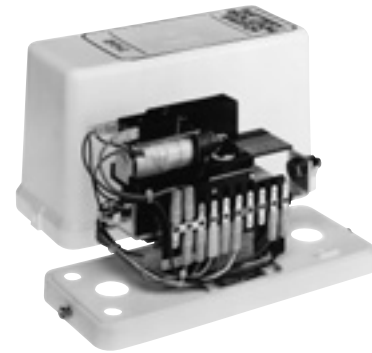

1073-437

Technical data – Electronic module

Voltage rating	DC 12 V	DC 24 V
Voltage rating range	ON 10.3 - 16 V OFF 9 - 16 V	18 - 32 V 16 - 32 V
	Correct switching performance is not guaranteed if the voltage falls below the minimum value.	
Temperature range electronic control unit	-40...+80 °C (-40...+176 °F)	
Operating current	ON approx. 30 A OFF approx. 10 A	approx. 15 A approx. 20 A
Excitation time	ON typically 100 ms OFF typically 20 ms	
Switching frequency	0.1 Hz max.	
Power consumption of electronic control unit	typically < 1 mA (when switched off or button operated)	
Control inputs	E-1073-.1...: E/A (ON/OFF), 'U-AUS' (undervoltage protection OFF), 'A-W' (auto reset) E-1073-.2...: 'T-EIN' (button ON), 'T-AUS' (button OFF)	
voltage	max. 32 V	
ON (high)	> 8 V	
OFF (low)	< 3 V	
power consumption	DC 12 V: typically 1 mA DC 24 V: typically 5 mA	
EMC	according to DIN 40839/ISO 7637	
Reverse polarity protection	If polarized incorrectly, the Battery Isolation Switch will operate immediately. The circuit breaker will trip after a few seconds.	
Undervoltage protection switching thresholds	optional with E-1073-.1... DC 12 V: 11.0 V ±0.2 V DC 24 V: 22.8 V ±0.2 V	
hysteresis	typically 0.5 V	
trip time	typically 40 sec	
Undervoltage status output ('UST'), optional with E-1073-.1... transistor output current load	minus switching corresponding to 2 W lamp load, short-circuit proof	
Automatic reset ('A-W'), (optional with E-1073-.1..., with series 921/922 only)	Reset after mechanical disconnection is provided by the integral electronic control after approx. 100 ms.	
Control current supply ('+US2'), with E-1073-.2... for T-EIN/T-AUS	May be connected to 20 control inputs. Noise-voltage proof, short-circuit proof	
Terminals	blade terminals 6.3x0.8 mm	
control terminals	blade terminals 6.3x0.8 mm	
Mass, with circuit breaker or isolation switch	approx. 2,000 g without enclosure approx. 2,500 g with enclosure	

Features

- Multiple functions in one unit
 - High performance circuit breaker providing battery and cable protection from overloads and short-circuits.
 - Master switch for ON/OFF operation
 - Electrical remote control
 - Undervoltage protection with status output
 - Auxiliary contacts (e.g. for generator disconnection)
 - Active reverse polarity protection of the entire vehicle electrical system
- Current ratings to 240 A (higher voltage ratings to special order)
- Closed-circuit current consumption < 1 mA

Technical description

E-T-A circuit breaker/battery isolation switches combined with electronic control unit E-1073 will meet a wide range of requirements.

Circuit breaker/battery isolation switches

The main switching contacts will open the plus, the minus or both poles according to model and application.

- **Series E-1073-....437**
Single pole thermal-magnetic circuit breaker for current ratings up to 240 A, to protect the vehicle electrical system from overloads and short circuits.
- **Series E-1073-....921**
Single pole battery isolation switch for current ratings up to 240 A.
- **Series E-1073-....922**
Double pole battery isolation switch for current ratings up to 120 A.

Electronic control unit

An electronic control unit enables the basic on/off function and two additional functions. The system voltage is connected across terminals +UB/-UB to provide the supply to the control unit and a feed is taken from +US1 for the remotely sited operating switch(es). The quiescent current drain is typically less than 1 mA, with a short duration excursion during excitation of the ON/OFF coils.

Basic function

Switch ON/OFF

Operation of the ON control switch will energise the switch-on coil for approximately 100 ms causing the main switching contacts to latch closed. Operation of the OFF control switch will cause the disconnect coil to trigger the release of the switching mechanism within approximately 20 ms. Both coil circuits are current limited to prevent damage through overheating.

Manual operation

An optional external operating knob is available to provide manual control in addition to electrical ON/OFF operation.

Reverse polarity protection

In the event of reverse polarity connection, the electronic control unit will immediately operate the battery switch to isolate the entire electrical system. The circuit breaker will trip after a short delay to protect the operating coils and must be re-set once the fault has been corrected.

Control functions

Type 1 E-1073-.1.. with ON/OFF switch

ON/OFF control switch input ("E/A")

The battery isolation switch can be operated on or off by an external control switch to plus.

Undervoltage protection (optional)

This optional feature protects the battery from deep discharge should electrical loads be left on.

The battery is automatically disconnected whenever the voltage falls below a critical value for more than 40 s. The unit is reset by operation of the control switch. Sustained undervoltage after reconnection causes the unit to disconnect again after approx. 40 s.

Overriding the undervoltage protection ("U-AUS")

Undervoltage protection may be overridden if required by connecting control output "U-AUS" to plus terminal or terminal 15.

Undervoltage status output ("UST")

Undervoltage is signalled immediately via the minus-switching, short-circuit proof transistor output (2 W lamp load).

Auto reset ("A-W"), optional with series 921 and 922

Immediate reset after unwanted mechanical disconnection (e.g. upon excessive vibration) is provided by the integral electronic control.

Type 2 E-1073-.2.. with ON/OFF button

ON/OFF control inputs ("T-ON/T-OFF")

ON/OFF function is provided by two external switches with a central control function, i.e. several systems can be operated simultaneously.

Additional control current supply ("US2")

If several circuit breakers/battery isolation switches are operated in parallel, switches can be supplied with control current from any of the electronic control units available. This power source is short-circuit proof, protected from noise voltages and will operate for 20 inputs.

Additional control input "ON/OFF Test" ("E/A")

This control input can be used for maintenance purposes. The battery isolation switch is switched on when plus voltage is applied, and switched off when plus voltage is removed.

Note

The circuit breaker should be in the OFF condition when connecting or replacing the battery.

Observe instructions for installation TM 9/9.3 D/E!

Typical applications

For road vehicles, e.g. buses and coaches

Series E-1073-1102-437-B3-K12-07-Si01-240 A

In this application, the E-T-A combined battery switch/circuit breaker has several functions:

- High performance circuit breaker rated at 240 A, providing battery and cable protection from overloads and short circuits.
- Isolation switch, for ON/OFF operation (e.g. for main system disconnection).
- Remote control via external, low-current circuit.
- Undervoltage protection from battery deep discharge should electrical loads be left on.
- Early under voltage signalisation via a warning lamp (undervoltage status output), located as required.
- Undervoltage operation can be overridden if required.
- Auxiliary contact to disconnect the generator field.
- Reverse polarity protection through immediate disconnection of the entire vehicle electrical system if the battery is incorrectly connected.

These functions allow the number of components and cables required to be reduced, with significant space and weight saving benefits.

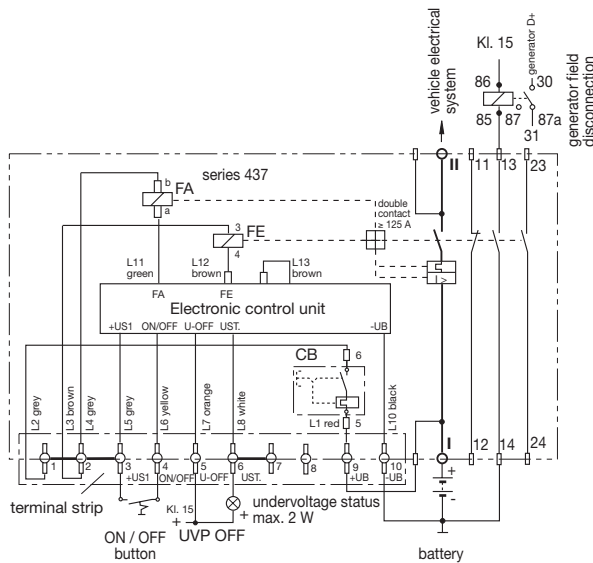

For rail vehicles, e.g. underground carriages

Series E-1073-1233-437-K60-06-Si01-200 A

In this application, the E-T-A combined battery switch/circuit breaker has two functions:

- High performance circuit breaker providing battery and cable protection from overloads and short circuits.
- Isolation switch between battery and loads.

In this application, an ON/OFF remote control switch can be provided in both the first and last carriages. This will enable all batteries to be disconnected from the power distribution system by the operation of one control, irrespective of its location. In the same way, all batteries can be re-connected by the operation of a single control switch.

This is extremely helpful during coupling/de-coupling of carriages for example. In addition the E/A test input permits the operation of individual battery switch/circuit breakers during maintenance.

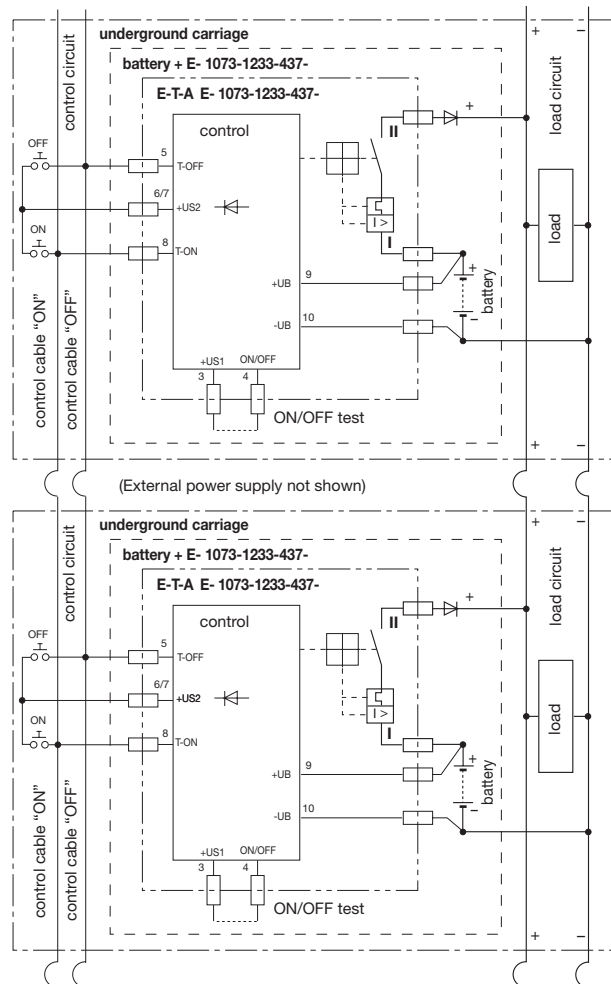

This is a metric design and millimeter dimensions take precedence ($\frac{\text{mm}}{\text{inch}}$)

All dimensions without tolerances are for reference only. In the interest of improved design, performance and cost effectiveness the right to make changes in these specifications without notice is reserved. Product markings may not be exactly as the ordering codes. Errors and omissions excepted.