

Description

An extremely versatile range of rocker switch/thermal circuit breakers (S-type TO CBE to EN 60934 with trip free mechanism) offering the choice of single pole, double pole with single pole protection, and double pole with protection on both poles. Designed for snap-in panel mounting with versions available for three different panel cut-out sizes. Illumination is optional and there is a range of colours and markings for the rocker. Under overload conditions the rocker returns to the OFF position. 6-way frame for 3120-F5 available upon request.

Any one of the following additional function modules can be supplied factory fitted to the rear of the switch/circuit breaker.

- Under voltage release coil (for double pole versions only).
- Magnetic trip coil for short circuit protection.
- Magnetic trip coil for remote relay trip.
- Auxiliary contacts for status signalling.
- Mechanical slide interlock.

Approved to CBE standard EN 60934 (IEC 60934).

Typical applications

Motors, transformers, solenoids, extra low voltage wiring systems, office machines, electro-medical equipment, power supplies, communications systems, medical equipment to EN 60601.

Standard current ratings and typical internal resistance values

Current rating (A)	Internal resistance per pole (Ω)	Current rating (A)	Internal resistance per pole (Ω)
0.1	94	3.5	0.0565
0.2	24	4	0.0435
0.3	12	4.5	0.0435
0.4	5.30	5	0.0325
0.5	4.20	6	0.0215
0.6	2.90	7	0.0165
0.8	1.50	8	0.0165
1	0.9	10	< 0.02
1.2	0.80	12	< 0.02
1.5	0.45	14	< 0.02
2	0.27	16	< 0.02
2.5	0.0785	18	< 0.02
3	0.0595	20	< 0.02

Illumination voltage/power consumption

operating voltage	power consumption	
	filament/neon	LED
6 V	60 mA	9 mA
12 V	20 mA	9 mA
24 V	20 mA	9 mA
48 V	20 mA	1.5 mA
115 V	< 1.5 mA	< 1 mA*
230 V	< 1.5 mA	< 1 mA*
415 V	< 1 mA	not available

* single pole version only

Approvals

Authority	Voltage ratings	Current ratings
VDE (EN 60934)	AC 240 V; DC 28 V DC 50 V DC 50 V	0.1...20 A 0.1...20 A 2-pole 0.1...10 A 1-pole
BV	AC 250 V; DC 28 V	0.1...20 A
UL, CSA	AC 250 V; DC 50 V	0.1...20 A
CCC	AC 250 V; DC 50 V	0.1...20 A



3120-F...

Technical data

For further details please see chapter: Technical Information

Voltage rating	AC 240 V; DC 50 V (AC 415 V to special order) (UL: AC 250 V; DC 50 V)		
Current ratings	0.1...20 A (up to 30 A to special order, single pole only)		
Typical life	1-pole AC 240 V: 0.1...20 A 30,000 operations at $1 \times I_N$, inductive DC 50 V: 0.1...4 A 30,000 operations at $1 \times I_N$, inductive 4.5...16 A 30,000 operations at $1 \times I_N$, resistive DC 28 V: 4.5...20 A 30,000 operations at $1 \times I_N$, inductive 2-pole AC 415 V: 0.1...16 A 10,000 operations at $1 \times I_N$, inductive AC 240 V: 0.1...16 A 50,000 operations at $1 \times I_N$, inductive 17...20 A 30,000 operations at $1 \times I_N$, inductive DC 50 V: 0.1...16 A 50,000 operations at $1 \times I_N$, inductive 17...20 A 10,000 operations at $1 \times I_N$, inductive		
Ambient temperature	-30...+60 °C (-22...+140 °F)		
Insulation co-ordination (IEC 60664 and 60664 A)	rated impulse withstand voltage 2.5 kV	pollution degree 2	reinforced insulation in operating area
Dielectric strength (IEC 60664 and 60664A) operating area between poles (2-pole)	test voltage AC 3,000 V AC 1,500 V		
Insulation resistance	> 100 MΩ (DC 500 V)		
Interrupting capacity I_{cn}	0.1...2 A $10 \times I_N$ 2.5...20 A 250 A 2-pole, or 150 A 1-pole		
Interrupting capacity (UL 1077)	I_N 0.1...2 A 2.5...3 A 3.5...8 A 9...16 A 18...20 A 0.1...20 A	U_N AC 250 V AC 250 V AC 250 V AC 250 V AC 250 V DC 50 V	2-pole 200 A 1,000 A 2,000 A 3,500 A 5,000 A 1,000 A
Degree of protection (IEC 60529/DIN 40050)	operating area IP40 (IP54 with water splash protection) terminal area IP00		
Vibration	8 g (57-500 Hz), ±0.61 mm (10-57 Hz) to IEC 60068-2-6, test Fc 10 frequency cycles/axis		
Shock	30 g (11 ms) to IEC 60068-2-27, test Ea		
Corrosion	96 hours at 5 % salt mist, to IEC 60068-2-11, test Ka		
Humidity	240 hours at 95 % RH, to IEC 60068-2-3, test Ca		
Mass	approx. 33 g (double pole) approx. 27 g (single pole)		

Ordering information

Type No.	
3120	rocker switch/circuit breaker
Mounting	
F snap in frame	
Size of frame	panel thickness
3 to fit mounting cut-out 50.5 x 21.5 mm	1-6.35 mm (.039-.250 in)
5 to fit mounting cut-out 44.5 x 22 mm	1-4 mm (.039-.157 in)
6 to fit mounting cut-out 45 x 33.7 mm	1.2-2.4 mm (.047-.094 in)
Number of poles	
0	2-pole, unprotected, switch only
1	1-pole, thermally protected
2	2-pole, thermally protected
5	2-pole, thermally protected on one pole only (terminals 11,12k,12l)
6	1-pole, unprotected, switch only
Mounting frame design	
1	collar height 1 mm
3	collar height 9 mm
4	collar height 2 mm with water splash protection (IP54), not with -F6...
U	with water splash protection and actuator guard
Terminal configuration	
P7	blade terminals 2x2.8x0.8 mm (QC 2x.110) (terminals 12(k), 22(k), 11, 21), not for under voltage module, not for switch
H7	12(k), 22(k): blade terminals 2x2.8-0.8 (QC 2x.110) 11, 21: terminal screws, not for switch
N7	as P7, but including shunt terminals 12(i) and 22 (i) as blade terminals 2x2.8x0.8 mm(QC 2x.110) not for under voltage module
G7	as H7, but including shunt terminals 12(i) and 22 (i) as blade terminals 2x2.8x0.8 mm(QC 2x.110)
Characteristic curve	
T1	thermal, 1.01-1.4 x I _N
Q1	switch only
Actuator style	
W	rocker
U	momentary switch
Switch colour designation	
opaque	translucent (for illuminated versions)
01 black	12 white
02 white	14 red
04 red	15 orange
	19 green
Rocker markings	
A	
B	
C	
D	
E	
F	
X	
X = without marking	
Rocker illumination (optional)	
B	filament ≤ 48V AC/DC; neon ≥ 115V AC
G	green LED, AC/DC
Y	yellow LED, AC/DC
R	red LED, AC/DC
Illumination voltage range	
0	4 - 7 V (B,G,Y,R)
1	10 - 14 V (B,G,Y,R)
2	20 - 28 V (B,G,Y,R)
3	90 - 140 V (B)
4	185 - 275 V (B)
5	42 - 54 V (B,Y,R)
Current ratings	
0.1...20 A	

3120 - F 3 2 1 - N7 T1 - W 14 A B 4 - 10 A ordering example
 3120 - F . 0 . - N7 Q1 - W - 20 A (switch only)

N.B.
 Switch only versions must be specified with -N7 or -G7 terminals.
 Terminals 12(k) and 22(k) are not fitted.

Typical time/current characteristics

single or double pole load

0.1 ... 2 A

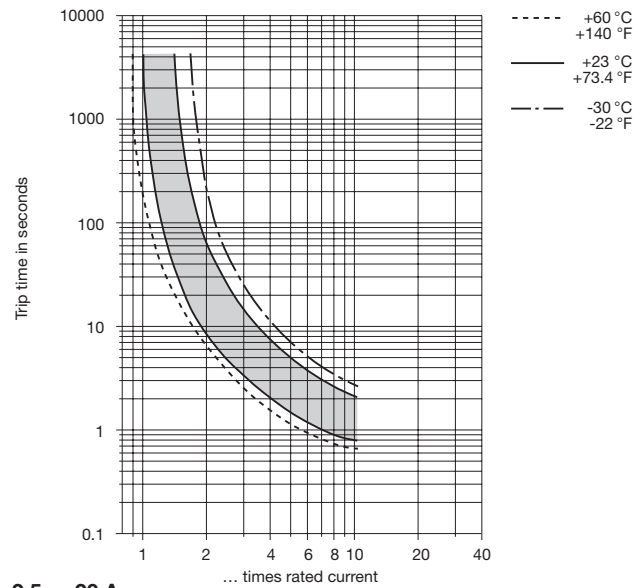

2.5 ... 20 A

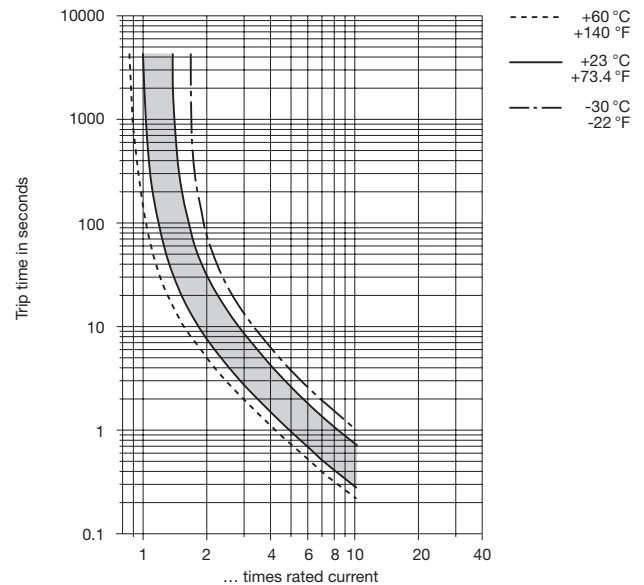

The time/current characteristic curve depends on the ambient temperature prevailing. In order to eliminate nuisance tripping, please multiply the circuit breaker current ratings by the derating factor shown below. See also section 9 – Technical information.

Ambient temperature °F	-22	-4	+14	+32	+73.4	+104	+122	+140
°C	-30	-20	-10	0	+23	+40	+50	+60
Derating factor	0.8	0.76	0.84	0.92	1	1.08	1.16	1.24

Internal connection diagrams

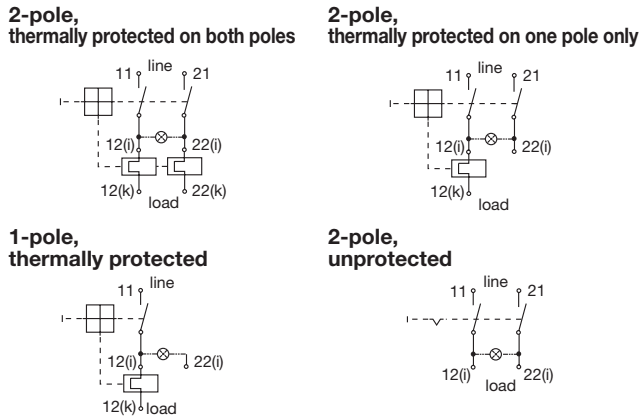

Dimensions

Style F3.1

collar height 1 mm / .039 in.

Actuating force max. 35 N
optional illumination in ON position

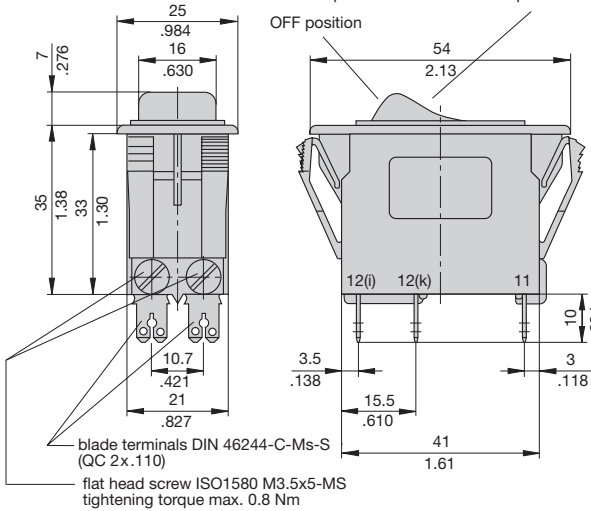

Installation drawing

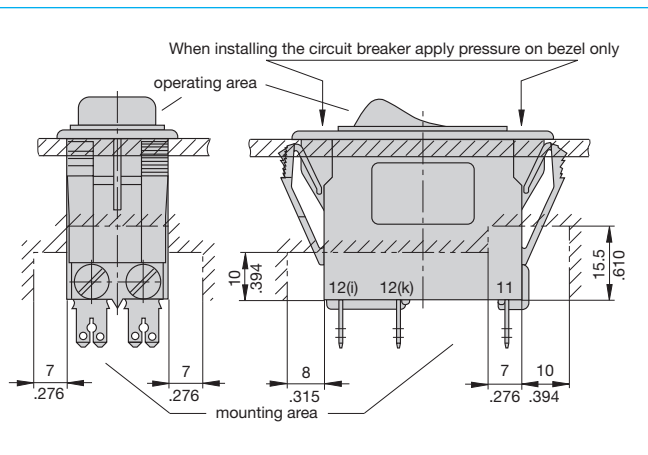

This is a metric design and millimeter dimensions take precedence (mm / inch)

Mounting style variants

Style F 3.3 collar height 9 mm (.354 in.)

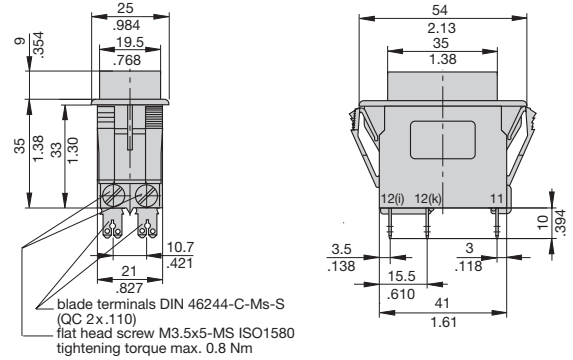

Style F 3.4

collar height 2 mm (.079 in.), with water splash protection

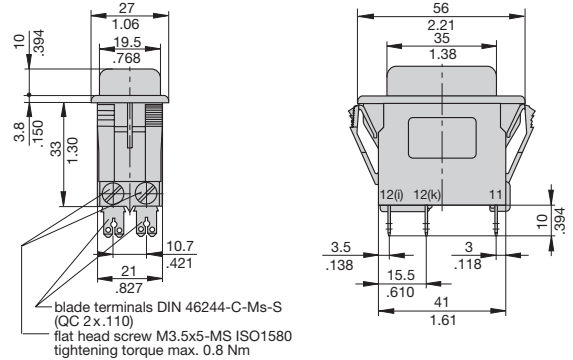

Style F 5.1

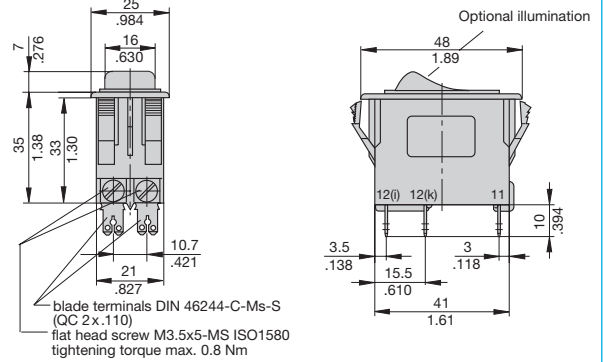

Style F 5.U

with water splash protection (IP54) and actuator guard

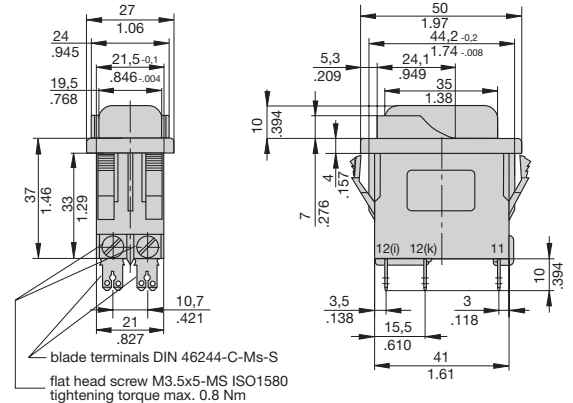

Dimension diagram for style F6 is available on request.

Accessories

Rear terminal shroud black (IP64) Y 304 275 01

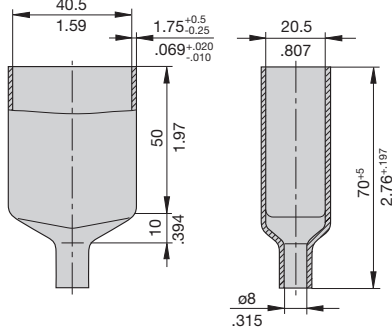

Water splash cover, transparent (IP66) for style -F5.. X 221 619 01

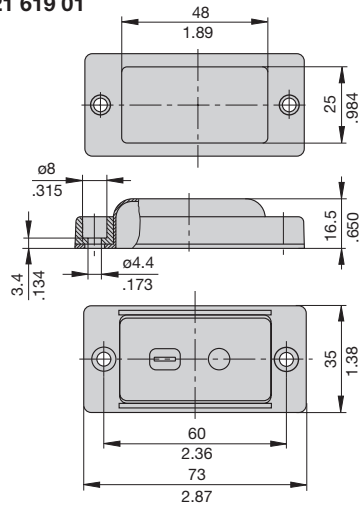

6-way frame for 3120-F5... upon request

Insulated cover Y 303 068 01

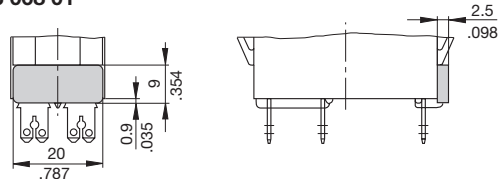

Terminal adapter Y 303 862 01

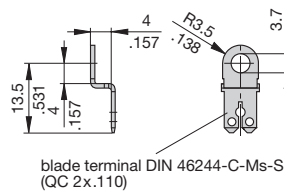

Spacer for 3120-F3... Y 303 675 01/02

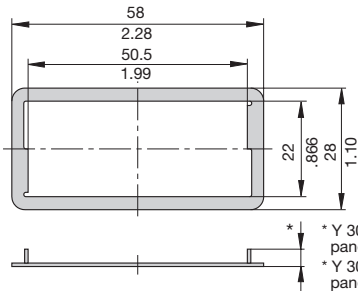

Spacer for 3120-F5... Y 303 676 01

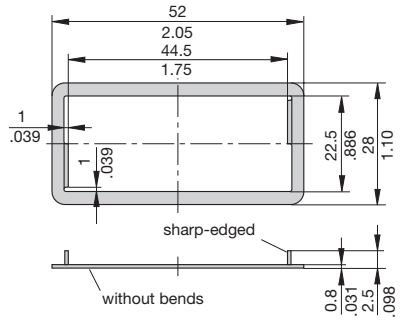

Blanking piece in -F3 frame Y 303 885 31

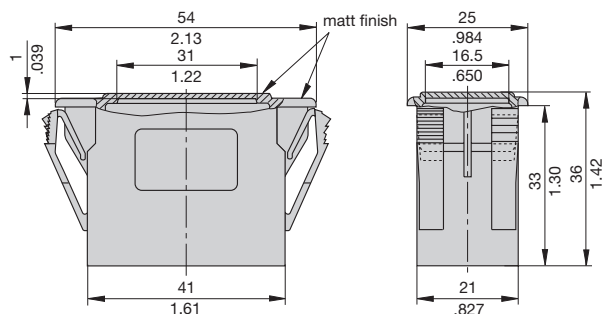

Cut-out dimensions

Cut-out for mounting style -F3 with rocker and push button

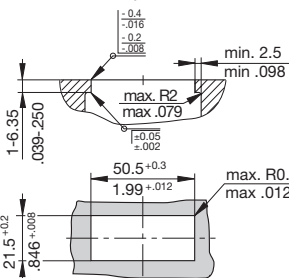

Cut-out for mounting style -F6 with rocker

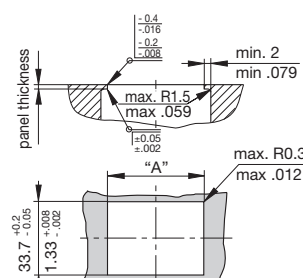

Cut-out for mounting style -F5 with rocker

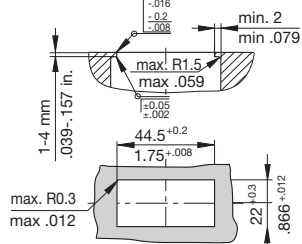

panel thickness	mm	1.2 ^{+0.4}	1.6 ^{+0.8}	2.4 ⁺¹
	inch	.047 ^{+0.016}	.063 ^{+0.031}	.094 ^{+0.039}
dimension	mm	45 ^{+0.2} / _{-0.05}	45 ^{+1.1} / _{-0.05}	45 ^{+2.2} / _{-0.05}
"A"	inch	1.77 ^{+0.008} / _{.002}	1.77 ^{+0.043} / _{.002}	1.77 ^{+0.087} / _{.002}

Edges of working parts: ISO 13715

This is a metric design and millimeter dimensions take precedence (mm)
inch

All dimensions without tolerances are for reference only. In the interest of improved design, performance and cost effectiveness the right to make changes in these specifications without notice is reserved. Product markings may not be exactly as the ordering codes. Errors and omissions excepted.

Description

E-T-A's proven type 3120 in a new attractive styling (S-type TO CBE to EN 60934 with trip free mechanism) offering the choice of single pole, double pole with single pole protection, and double pole with protection on both poles. Designed for snap-in panel mounting with illumination as an option. Under overload conditions the rocker returns to the OFF position.

Any one of the following additional function modules can be supplied factory fitted to the rear of the switch/circuit breaker.

- Under voltage release coil (for double pole versions only).
- Magnetic trip coil for short circuit protection.
- Magnetic trip coil for remote relay trip.
- Auxiliary contacts for status signalling.
- Mechanical slide interlock.

Approved to CBE standard EN 60934 (IEC 60934).

Available accessories: water splash protection and actuator guard to prevent inadvertent operation.

Typical applications

Motors, transformers, solenoids, extra low voltage wiring systems, office machines, electro-medical equipment, power supplies, communications systems, boating.

Standard current ratings and typical internal resistance values

Current rating (A)	Internal resistance per pole (Ω)	Current rating (A)	Internal resistance per pole (Ω)
0.1	94	3.5	0.0565
0.2	24	4	0.0435
0.3	12	4.5	0.0435
0.4	5.30	5	0.0325
0.5	4.20	6	0.0215
0.6	2.90	7	0.0165
0.8	1.50	8	0.0165
1	0.9	10	< 0.02
1.2	0.80	12	< 0.02
1.5	0.45	14	< 0.02
2	0.27	16	< 0.02
2.5	0.0785	18	< 0.02
3	0.0595	20	< 0.02

Illumination voltage/power consumption

operating voltage	power consumption	
	filament/neon	LED
6 V	60 mA	9 mA
12 V	20 mA	9 mA
24 V	20 mA	9 mA
48 V	20 mA	1.5 mA
115 V	< 1.5 mA	< 1 mA*
230 V	< 1.5 mA	< 1 mA*
415 V	< 1 mA	not available

* single pole version only

Approvals

Authority	Voltage ratings	Current ratings
VDE, (EN 60934)	AC 240 V; DC 28 V DC 50 V DC 50 V	0.1...20 A 0.1...20 A 2-pole 0.1...10 A 1-pole
BV	AC 250 V; DC 28 V	0.1...20 A
UL, CSA	AC 250 V; DC 50 V	0.1...20 A
CCC	AC 250 V; DC 50 V	0.1...20 A



3120-F7..

Technical data

For further details please see chapter: Technical Information

Voltage rating	AC 240 V; DC 50 V (AC 415 V to special order) (UL: AC 250 V; DC 50 V)		
Current ratings	0.1...20 A (up to 30 A to special order, single pole only)		
Typical life	AC 240 V:	0.1...20 A	30,000 operations at 1 x I _N , inductive
	DC 50 V:	0.1...4 A	30,000 operations at 1 x I _N , inductive
		4.5...16 A	30,000 operations at 1 x I _N , resistive
	DC 28 V:	4.5...20 A	30,000 operations at 1 x I _N , inductive
Ambient temperature	AC 415 V:	0.1...16 A	10,000 operations at 1 x I _N , inductive
	AC 240 V:	0.1...16 A	50,000 operations at 1 x I _N , inductive
		17...20 A	30,000 operations at 1 x I _N , inductive
	DC 50 V:	0.1...16 A	50,000 operations at 1 x I _N , inductive
	17...20 A	10,000 operations at 1 x I _N , inductive	
Ambient temperature	-30...+60 °C (-22...+140 °F)		
Insulation co-ordination (IEC 60664 and 60664 A)	rated impulse withstand voltage	2.5 kV	pollution degree 2
	reinforced insulation in operating area		
Dielectric strength (IEC 60664 and 60664A) operating area between poles (2-pole)	test voltage	AC 3,000 V	
	operating area	AC 1,500 V	
	between poles (2-pole)	AC 1,500 V	
Insulation resistance	> 100 MΩ (DC 500 V)		
Interrupting capacity I _{cn}	0.1...2 A	10 x I _N	
	2.5...20 A	250 A 2-pole, or 150 A 1-pole	
Interrupting capacity (UL 1077)	I _N	U _N	2-pole
	0.1...2 A	AC 250 V	200 A
	2.5...3 A	AC 250 V	1,000 A
	3.5...8 A	AC 250 V	2,000 A
	9...6 A	AC 250 V	3,500 A
	18...20 A	AC 250 V	5,000 A
	DC 50 V	1,000 A	
Degree of protection (IEC 60529/DIN 40050)	operating area IP40 (IP54 with water splash protection) terminal area IP00		
Vibration	8 g (57-500 Hz), ±0.61 mm (10-57 Hz) to IEC 60068-2-6, test Fc 10 frequency cycles/axis		
Shock	30 g (11 ms) to IEC 60068-2-27, test Ea		
Corrosion	96 hours at 5 % salt mist, to IEC 60068-2-11, test Ka		
Humidity	240 hours at 95 % RH, to IEC 60068-2-3, test Ca		
Mass	approx. 33 g (double pole)		
	approx. 27 g (single pole)		

Ordering information

Type No.	
3120	rocker switch/circuit breaker
Mounting	
F snap in frame	
Size of frame panel thickness	
7	to fit mounting cut-out 44.5x22mm(1.75x.866 in) 1-4 mm(.039-.157 in)
Number of poles	
0	2-pole, unprotected, switch only
1	1-pole, thermally protected
2	2-pole, thermally protected
5	2-pole, thermally protected on one pole only (terminals 11,12k,12l)
6	1-pole, unprotected, switch only
Mounting frame design	
N	grey frame
P	snap-on actuator guard grey
Q	snap-on water splash cover grey
R	black frame
S	snap-on actuator guard black
T	snap-on water splash cover black
Terminal configuration	
P7	blade terminals 2x2.8x0.8 mm (QC 2x.110) (terminals 12(k), 22(k), 11, 21), not for under voltage module, not for switch
H7	12(k), 22(k): blade terminals 2x2.8-0.8 (QC 2x.110) 11, 21: terminal screws, not for switch
N7	as P7, but including shunt terminals 12(i) and 22 (i) as blade terminals 2x2.8x0.8 mm(QC 2x.110) not for under voltage module
G7	as H7, but including shunt terminals 12(i) and 22 (i) as blade terminals 2x2.8x0.8 mm(QC 2x.110)
Characteristic curve	
T1	thermal, 1.01-1.4 x I _N
Q1	switch only
Actuator style	
A	rocker
Switch colour designation	
20	blue opaque
30	blue translucent
Rocker markings	
Q	"I" and "0" moulded in
Push button illumination (optional)	
B	filament, AC/DC
G	green LED, AC/DC
R	red LED, AC/DC
Illumination voltage range (optional)	
0	4 - 7 V (G,B,R)
1	10 - 14 V (G,B,R)
2	20 - 28 V (G,B,R)
3	90 - 140 V (B)
4	185 - 275 V (B)
5	42 - 54 V (B,R)
Current ratings	
0.1...20 A	
3120 - F 7 2 N - N7 T1 - A 20 Q B 4 - 10 A ordering example	
3120 - F . 0 N - N7 Q1 - A 20 Q B 4 - 20 A (switch only)	

N.B.
Switch only versions must be specified with -N7 or -G7 terminals.
Terminals 12(k) and 22(k) are not fitted.

Typical time/current characteristics

single or double pole load

0.1 ... 2 A

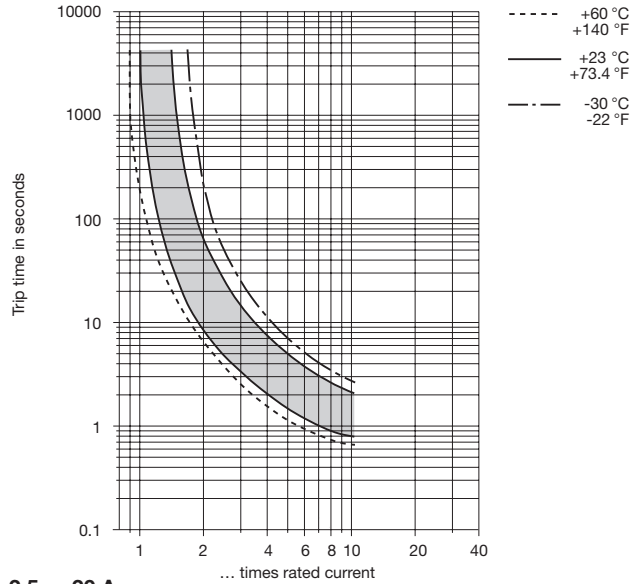

2.5 ... 20 A

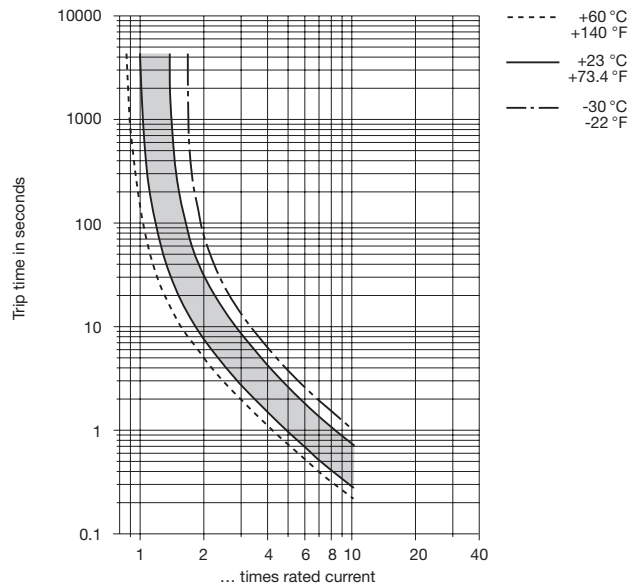

The time/current characteristic curve depends on the ambient temperature prevailing. In order to eliminate nuisance tripping, please multiply the circuit breaker current ratings by the derating factor shown below. See also section 9 – Technical information.

Ambient temperature °F	-22	-4	+14	+32	+73.4	+104	+122	+140
°C	-30	-20	-10	0	+23	+40	+50	+60
Derating factor	0.8	0.76	0.84	0.92	1	1.08	1.16	1.24

Dimensions

Style -F7.N and F7.R

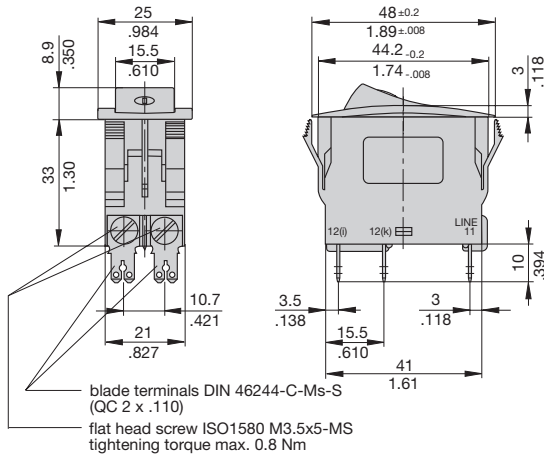

Style -F7.P and F7.S

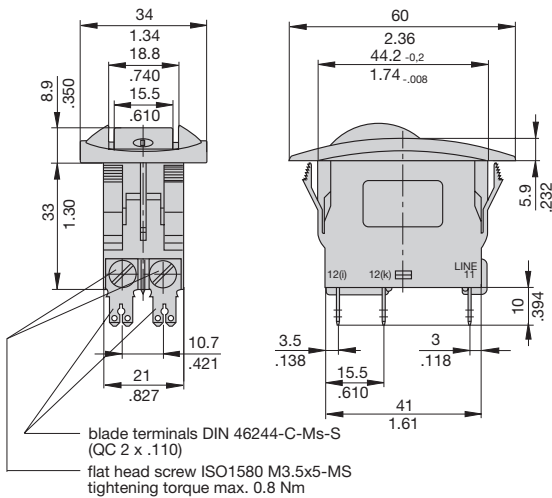

Style -F7.Q and F7.T

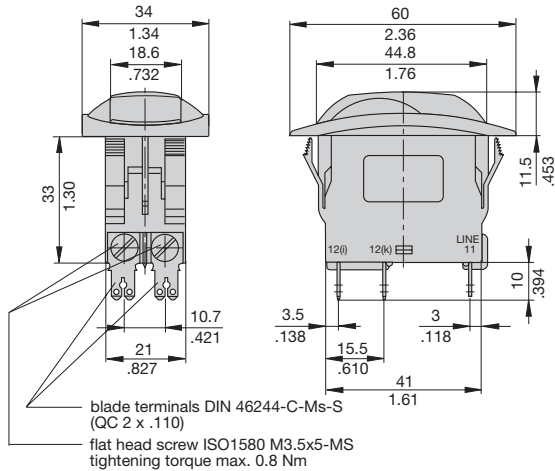

Internal connection diagrams

2-pole, thermally protected on both poles

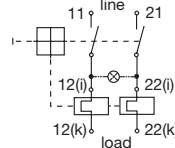

2-pole, thermally protected on one pole only

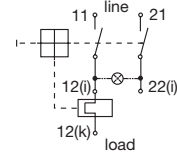

1-pole, thermally protected

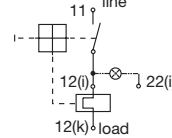

2-pole, unprotected

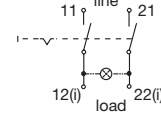

Installation drawing

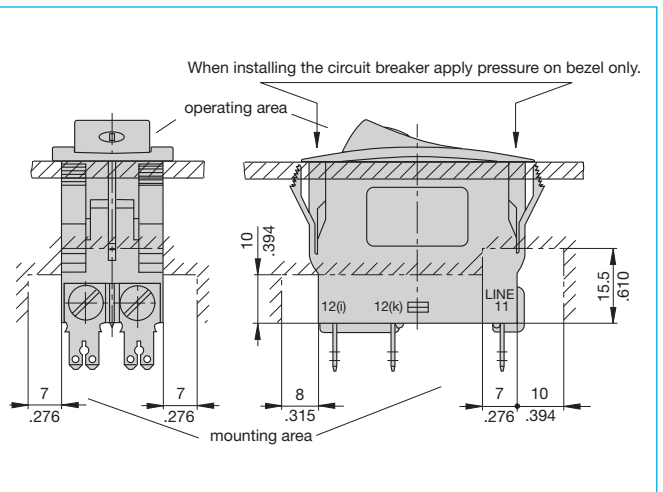

Panel cut-out

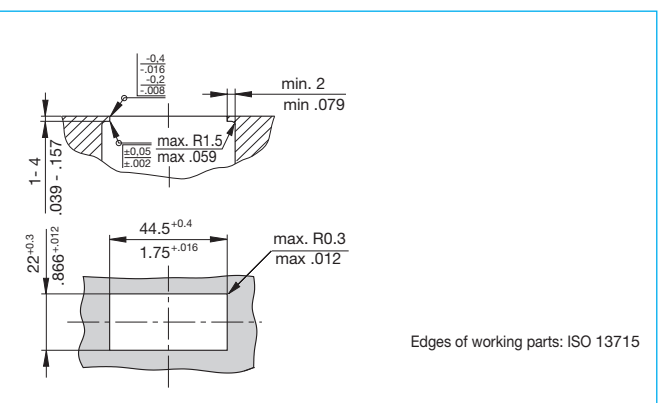

This is a metric design and millimeter dimensions take precedence (mm/inch)

Accessories

Insulated cover Y 303 068 01

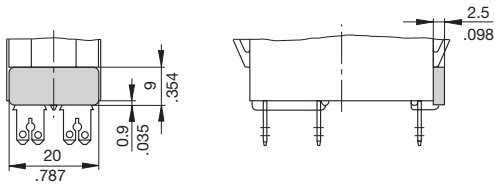

Terminal adapter Y 303 862 01

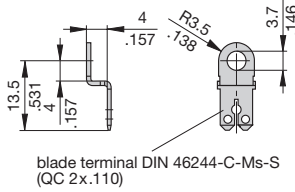

Spacer Y 303 676 01

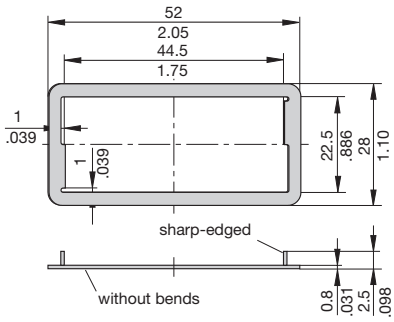

Rear terminal shroud black (IP64) Y 304 275 01

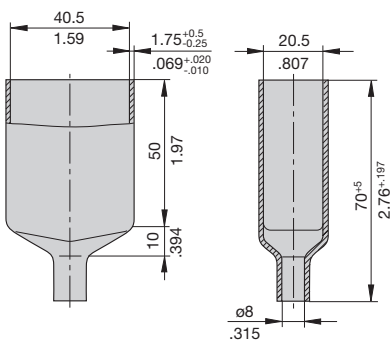

Translucent water splash cover (IP54)

X 222 143 01

Consisting of

- Y 307 097 01 snap-on frame with actuator guard

- Y 307 096 01 soft plastic cover

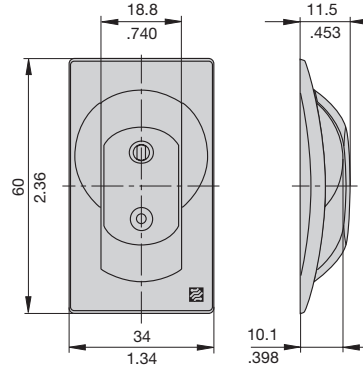

Snap-on frame with actuator guard (can be snapped on as switch-on protection or switch-off protection)

Y 307 097 01

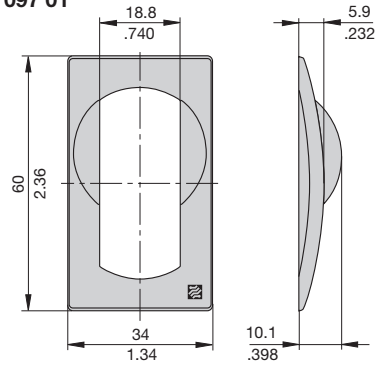

This is a metric design and millimeter dimensions take precedence ($\frac{\text{mm}}{\text{inch}}$)

All dimensions without tolerances are for reference only. In the interest of improved design, performance and cost effectiveness the right to make changes in these specifications without notice is reserved. Product markings may not be exactly as the ordering codes. Errors and omissions excepted.

Description

Switch/thermal trip free circuit breaker (S-type TO CBE to EN 60934) with standard isolator style two button operation. Single button press-to-reset version also available. Both types can be supplied in single pole configuration only, in double pole with single pole protection, and in double pole with protection on both poles. Designed for snap-in panel mounting. There is a choice of push button colour combinations and illumination is optional.

Any one of the following additional function modules can be supplied factory fitted to the rear of the switch/circuit breaker:

- Under voltage release coil (for double pole versions only).
- Magnetic trip coil for short circuit protection.
- Magnetic trip coil for remote relay trip.
- Auxiliary contacts for status signalling.
- Mechanical slide interlock.

Approved to CBE standard EN 60934 (IEC 60934).

Typical applications

Motors, transformers, solenoids, extra low voltage wiring systems, office machines, electro-medical equipment, power supplies, communications systems, industrial controls.

Standard current ratings and typical internal resistance values

Current rating (A)	Internal resistance per pole (Ω)	Current rating (A)	Internal resistance per pole (Ω)
0.1	94	3.5	0.0565
0.2	24	4	0.0435
0.3	12	4.5	0.0435
0.4	5.30	5	0.0325
0.5	4.20	6	0.0215
0.6	2.90	7	0.0165
0.8	1.50	8	0.0165
1	0.9	10	< 0.02
1.2	0.80	12	< 0.02
1.5	0.45	14	< 0.02
2	0.27	16	< 0.02
2.5	0.0785	18	< 0.02
3	0.0595	20	< 0.02

Illumination voltage/power consumption

operating voltage	power consumption	
	filament/neon	LED
6 V	60 mA	9 mA
12 V	20 mA	9 mA
24 V	20 mA	9 mA
48 V	20 mA	1.5 mA
115 V	< 1.5 mA	< 1 mA*
230 V	< 1.5 mA	< 1 mA*
415 V	< 1 mA	not available

* single pole version only

Approvals

Authority	Voltage ratings	Current ratings
VDE, (EN 60934)	AC 240 V; DC 28 V DC 50 V DC 50 V	0.1...20 A 0.1...20 A 2-pole 0.1...10 A 1-pole
BV	AC 250 V; DC 28 V	0.1...20 A
UL, CSA	AC 250 V; DC 50 V	0.1...20 A
CCC	AC 250 V; DC 50 V	0.1...20 A



3120-F...

Technical data

For further details please see chapter: Technical Information

Voltage rating	AC 240 V; DC 50 V (AC 415 V to special order) (UL: AC 250 V; DC 50 V)	
Current ratings	0.1...20 A (up to 30 A to special order, single pole only)	
Typical life	1-pole AC 240 V: 0.1...20 A 30,000 operations at $1 \times I_N$, inductive DC 50 V: 0.1...4 A 30,000 operations at $1 \times I_N$, inductive 4.5...16 A 30,000 operations at $1 \times I_N$, resistive DC 28 V: 4.5...20 A 30,000 operations at $1 \times I_N$, inductive 2-pole AC 415 V: 0.1...16 A 10,000 operations at $1 \times I_N$, inductive AC 240 V: 0.1...16 A 50,000 operations at $1 \times I_N$, inductive 17...20 A 30,000 operations at $1 \times I_N$, inductive DC 50 V: 0.1...16 A 50,000 operations at $1 \times I_N$, inductive 17...20 A 10,000 operations at $1 \times I_N$, inductive	
Ambient temperature	-30...+60 °C (-22...+140 °F)	
Insulation co-ordination (IEC 60664 and 60664 A)	rated impulse withstand voltage 2.5 kV	pollution degree 2 reinforced insulation in operating area
Dielectric strength (IEC 60664 and 60664A)	test voltage operating area between poles (2-pole)	AC 3,000 V AC 1,500 V
Insulation resistance	> 100 MΩ (DC 500 V)	
Interrupting capacity I_{cn}	0.1...2 A $10 \times I_N$ 2.5...20 A 250 A 2-pole, or 150 A 1-pole	
Interrupting capacity (UL 1077)	I_N	U_N
	0.1...2 A	AC 250 V
	2.5...3 A	AC 250 V
	3.5...8 A	AC 250 V
	9...16 A	AC 250 V
	18...20 A	AC 250 V
	0.1...20 A	DC 50 V
Degree of protection (IEC 60529/DIN 40050)	operating area IP40 terminal area IP00	
Vibration	8 g (57-500 Hz), ±0.61 mm (10-57 Hz) to IEC 60068-2-6, test Fc 10 frequency cycles/axis	
Shock	30 g (11 ms) to IEC 60068-2-27, test Ea	
Corrosion	96 hours at 5 % salt mist, to IEC 60068-2-11, test Ka	
Humidity	240 hours at 95 % RH, to IEC 60068-2-3, test Ca	
Mass	approx. 33 g (double pole) approx. 27 g (single pole)	

Ordering information

Type No.	
3120	push button switch/circuit breaker
Mounting	
F snap in frame	
Size of frame	
2	flange mounting, special frame for fitting splash cover
3	to fit mounting cut-out 50.5 x 21.5 mm (1.99 x 8.47 in) panel thickness 1 - 6.35 mm (.039 - .250 in)
Number of poles	
0	2-pole, unprotected, switch only
1	1-pole, thermally protected
2	2-pole, thermally protected
5	2-pole, thermally protected on one pole only (terminals 11,12k,12i)
6	1-pole, unprotected, switch only
Mounting frame design	
F with 2 push buttons	
G with 1 push button (switch-on only)	
Terminal configuration	
P7 blade terminals 2x2.8x0.8mm(QC 2x.110) (terminals 12(k), 22(k), 11, 21), not for under voltage module, not for switch	
H7 12(k), 22(k): blade terminals 2x2.8-0.8 (QC 2x.110) 11, 21: terminal screws, not for switch	
N7 as P7, but including shunt terminals 12(i) and 22 (i) as blade terminals 2x2.8x0.8 mm (QC 2x.110) not for under voltage module	
G7 as H7, but including shunt terminals 12(i) and 22 (i) as blade terminals 2x2.8x0.8 mm (QC 2x.110)	
Characteristic curve	
T1 thermal, 1.01-1.4 I _N	
Q1 switch only, only for N7 or G7 terminals	
Switch style/colour	
D 1 push button (re-set only)	
Z 1 push button (momentary switch)	
01X black	
04X red	
12X white translucent	
19X green translucent	
S 2 push buttons on/off	
GRX green translucent/red	
WRX white translucent/red	
WBX white translucent/black	
Push button illumination (optional)	
B filament AC/DC	
L neon, AC	
G green LED, AC/DC	
Y yellow LED, AC/DC	
R red LED, AC/DC	
Illumination voltage range (optional)	
0 4 - 7 V (B,G,Y,R)	
1 10 - 14 V (B,G,Y,R)	
2 20 - 28 V (B,G,Y,R)	
3 90 - 140 V (L)	
4 185 - 275 V (L)	
5 42 - 54 V (B,Y,R)	
Current ratings	
0.1...20 A	
3120 - F 3 2 F - N7 T1 - S GRX L 4 - 10 A	ordering example
3120 - F 3 0 F - N7 Q1 - S - 20 A	switch only

N.B.
Switch only versions must be specified with -N7 or -G7 terminals.
Terminals 12(k) and 22 (k) are not fitted.

Typical time/current characteristics

single or double pole load

0.1 ... 2 A

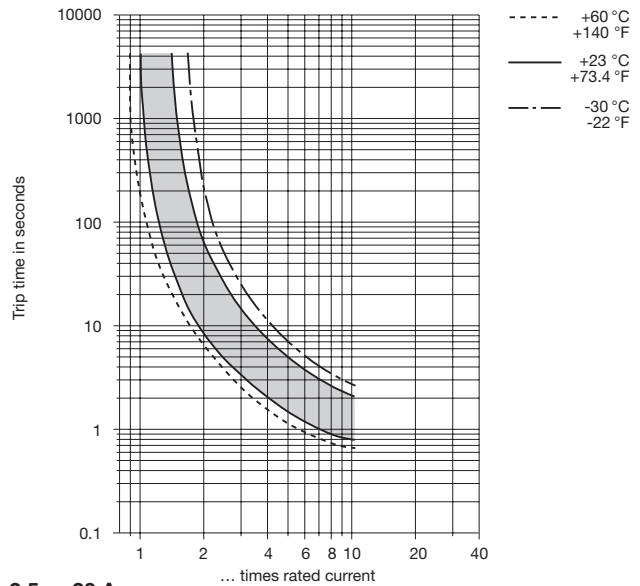

2.5 ... 20 A

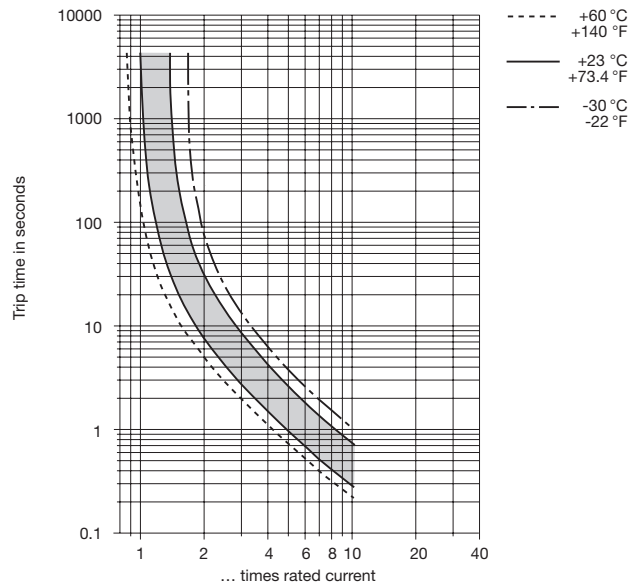

The time/current characteristic curve depends on the ambient temperature prevailing. In order to eliminate nuisance tripping, please multiply the circuit breaker current ratings by the derating factor shown below. See also section 9 – Technical information.

Ambient temperature °F	-22	-4	+14	+32	+73.4	+104	+122	+140
°C	-30	-20	-10	0	+23	+40	+50	+60
Derating factor	0.8	0.76	0.84	0.92	1	1.08	1.16	1.24

Accessories

Insulated cover Y 303 068 01

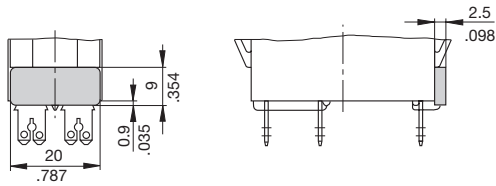

Terminal adapter Y 303 862 01

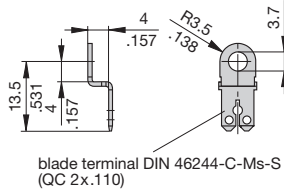

Spacer for 3120-F3... Y 303 675 01/02

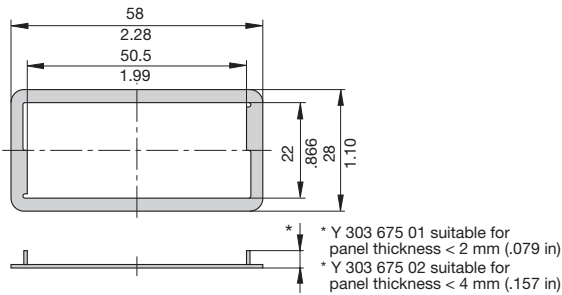

Blanking piece in -F3 frame Y 303 885 31

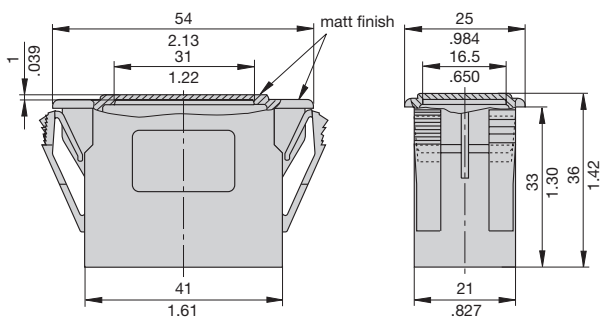

Rear terminal shroud black (IP64) Y 304 275 01

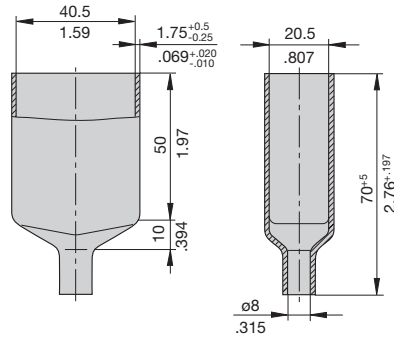

Water splash cover, transparent (IP66) for style 3120-F2.F-... X 221 619 01 consisting of - retaining clip 305 551 01 - cover Y 306 001 01

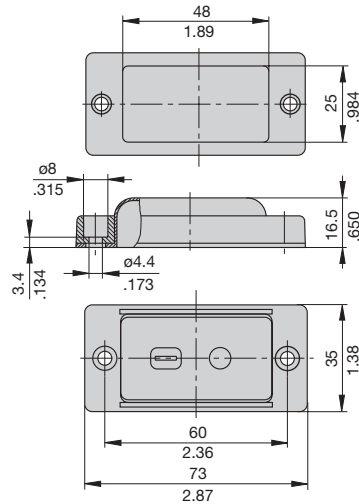

This is a metric design and millimeter dimensions take precedence ($\frac{\text{mm}}{\text{inch}}$)

All dimensions without tolerances are for reference only. In the interest of improved design, performance and cost effectiveness the right to make changes in these specifications without notice is reserved. Product markings may not be exactly as the ordering codes. Errors and omissions excepted.

Description

A module supplied factory fitted to type 3120-F to provide electrically separate changeover contacts which operate as the main contacts open/close. Ideally suited to status signalling and sequence switching.

Typical applications

Monitoring of the switching position of the circuit breaker or any connected load.

Ordering information

Type No.		
X3120	Module for type 3120 and type 3140	
Function		
S	auxiliary contact module	
Contact configuration		
0	change-over contact	
Terminal design		
1	blade terminals 2.8 x 0.5 (QC .110), silver plated	
Contact rating		
AC		
Voltage rating	Current rating	
A 10 V-250 V	0.1...4 A	
	DC (not approved)	
	Voltage rating	Current rating
	12 V	0.1...4 A
	24 V	0.1...4 A
60 V	0.1...1 A	
110 V	0.1...0.5 A	
220 V	0.1...0.25 A	
B 5 V-250 V	0.05...1 A	
5 V-250 V 0.05...1 A		
Supply condition		
M	module mounted to circuit breaker 3120-...	
X3120 - S 0 1 A M	ordering example	

Approvals (complete circuit breaker/module assembly)

Authority	Voltage ratings	Current ratings
VDE (EN 60934)	AC 250 V; DC 28 V	0.05...4 A
UL, CSA	AC 250 V	0.05...4 A

Dimensions

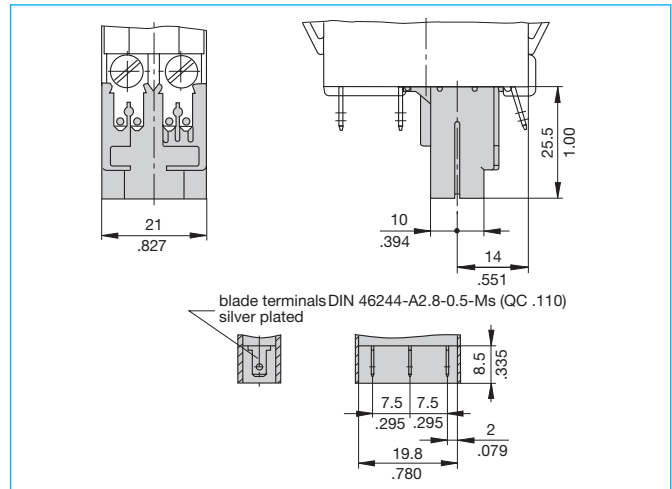

Internal connection diagram

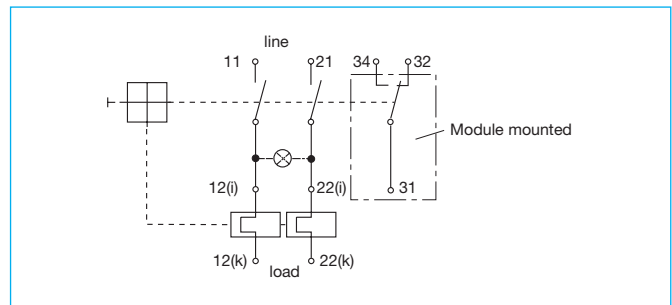

Technical data

Voltage rating	AC 250 V; DC 220 V
Current rating	0.1...4 A / 0.05...1 A
Typical life	50,000 operations
Ambient temperature	-30...+60 °C (-22...+140 °F)
Dielectric strength (IEC 60664 and 60664A) between main and auxiliary circuit	test voltage AC 3,000 V
Insulation resistance	> 100 MΩ (DC 500 V)
Vibration	6 g (type X3120-S...A) 8 g (type X3120-S...B) (57-500 Hz), ±0.46 mm (10-57 Hz) to IEC 60068-2-6, test Fc 10 frequency cycles/axis
Shock	15 g (11 ms), type X3120-S...A 20 g (11 ms), type X3120-S...B to IEC 60068-2-27, test Ea
Corrosion	96 hours at 5 % salt mist, to IEC 60068-2-11, test Ka
Humidity	240 hours at 95 % RH to IEC 60068-2-30, test Ca
Mass	approx. 38 g (complete assembly)

This is a metric design and millimeter dimensions take precedence ($\frac{\text{mm}}{\text{inch}}$)

All dimensions without tolerances are for reference only. In the interest of improved design, performance and cost effectiveness the right to make changes in these specifications without notice is reserved. Product markings may not be exactly as the ordering codes. Errors and omissions excepted.

Description

A module suitable for all double pole versions of type 3120-F to trip the main switch/circuit breaker mechanism in the event of loss of voltage. When the voltage is restored the rocker switch must be reset to reconnect the load, thereby avoiding the safety hazards associated with automatic re-starting of machinery.

Note: Basic unit 3120-...-H7 or -G7: screw terminals necessary.

Typical applications

Machines such as power tools, industrial equipment and domestic appliances where automatic restart after restoration of power could be dangerous (EC Machinery Directive).

Dimensions

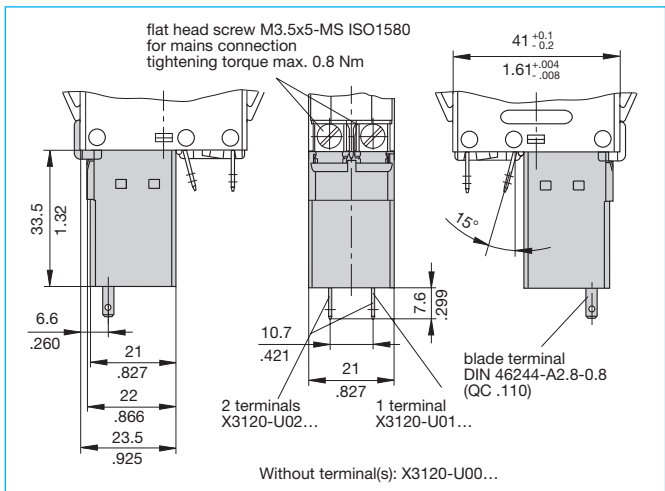

Ordering information

Type No.	
X3120	Module for type 3120
Function	
U	undervoltage release module
Terminal design	
00	standard (without separate connections)
01	1 blade terminal 2.8x0.8 (QC .110)
02	2 blade terminals 2.8x0.8 (QC .110)
Voltage ratings	
00	AC 230/240 V 50/60 Hz
01	AC 120 V 50/60 Hz
02	AC 100 V 50/60 Hz
03	DC 24 V
Assembly status	
M	module mounted to the circuit breaker 3120
X3120 -U 00 00 M	ordering example

Internal connection diagrams

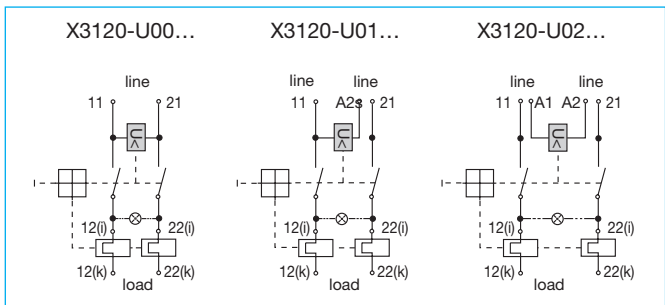

Technical data

Voltage ratings	AC 100; 120 V; 230/240 V 50/60 Hz DC 24 V
Voltage tolerance	+10%/-15%
Current consumption	approx. 2.5 mA
Typical life	20,000 operations
Release values	$0.2 \times U_N < U < 0.7 \times U_N$ (at a rated voltage of AC 100 V the device may release at 70 V and must release at 20 V)
Release delay	$t < 20$ ms
Latch-in values	$\geq 85 \% U_N$
Ambient temperature	-30...+60 °C (-22...+140 °F)
Vibration	8 g (57-500 Hz) ± 0.61 mm (10-57 Hz) to IEC 60068-2-6, test Fc 10 frequency cycles/axis
Shock	30 g (11 ms) to IEC 60068-2-27, test Ea
Corrosion	48 hours at 5 % salt mist, to IEC 60068-2-11, test Ka
Humidity	240 hours at 95% RH to IEC 60068-2-30, test Ca
Mass	approx. 53 g (complete assembly)

Approvals (complete circuit breaker/module assembly)

Authority	Voltage ratings
VDE (EN 60934)	AC 100...240 V; DC 24 V
UL, CSA	AC 100...240 V; DC 24 V

This is a metric design and millimeter dimensions take precedence ($\frac{\text{mm}}{\text{inch}}$)

All dimensions without tolerances are for reference only. In the interest of improved design, performance and cost effectiveness the right to make changes in these specifications without notice is reserved. Product markings may not be exactly as the ordering codes. Errors and omissions excepted.

Description

A module which adds remote trip capability to all versions of type 3120-F. A voltage applied across the coil, by means of an external sensor for example, will cause disconnection of the main switch/circuit breaker mechanism.

Typical applications

Electrical monitoring of safety systems, remote trip.

Ordering information

Type No.	
X3120	Module for type 3120
Function	
M	magnetic relay trip module
Style	
2	magnetic remote trip coil
Terminal design	
P7	blade terminals 2x2.8x0.8 (QC 2x.110) tin plated
Supply condition	
M	module mounted to the circuit breaker
Voltage ratings	
AC 12, 24, 48, 60, 120, 220, 230, 240 V	
DC 12, 24 V	
X3120 - M 2 P7 M - 12 V ordering example	

Standard voltage ratings and typical internal resistance values

Voltage rating (V)	Internal resistance per pole (Ω)	Voltage rating (V)	Internal resistance per pole (Ω)
12 V AC/DC	0.78	120 V AC	71.0
24 V AC/DC	3.3	220 V AC	312
48 V AC	11.9	230 V AC	312
60 V AC	18.5	240 V AC	312

Approvals (complete circuit breaker/module assembly)

Authority	Voltage ratings
VDE (EN 60934)	AC 12...240 V; DC 12...24 V
UL, CSA	AC 12...240 V; DC 12...24 V

Dimensions

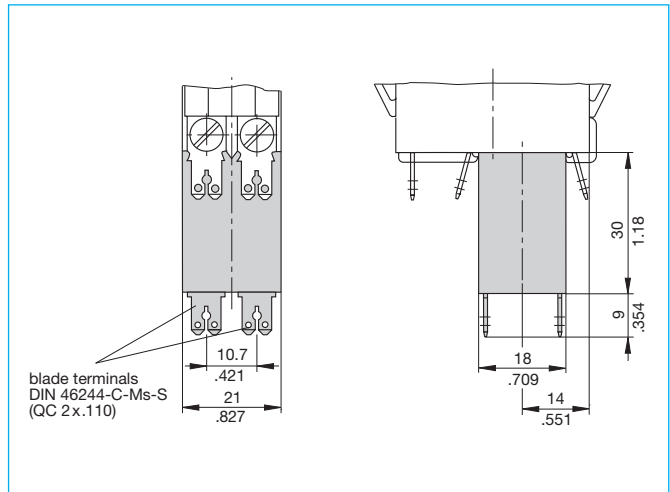

Internal connection diagram

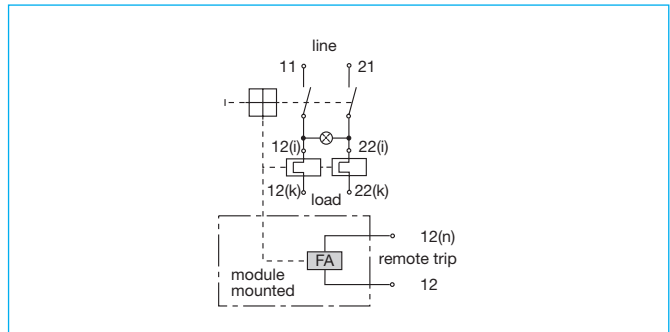

Technical data

Voltage ratings	AC 12...240 V; DC 12...24 V
Power consumption	approx. 200 W
Pulse operation	20 ms < t _{ON} < 100 ms / t _{OFF} > 10 sec
Release delay	t < 20 ms
Typical life	50,000 operations at U _N
Ambient temperature	-30...+60 °C (-22...+140 °F)
Dielectric strength (IEC 60664 and 60664A) between main circuit and trip coil circuit	test voltage AC 3,000 V
Insulation resistance	> 100 MΩ (DC 500 V)
Vibration	8 g (57-500 Hz) ±0.61 mm (10-57 Hz) to IEC 60068-2-6, test Fc 10 frequency cycles/axis
Shock	30 g (11 ms) to IEC 60068-2-27, test Ea
Corrosion	96 hours at 5 % salt mist, to IEC 60068-2-11, test Ka
Humidity	240 hours at 95 % RH to IEC 60068-2-30, test Ca
Mass	approx. 53 g (complete assembly)

This is a metric design and millimeter dimensions take precedence ($\frac{\text{mm}}{\text{inch}}$)

All dimensions without tolerances are for reference only. In the interest of improved design, performance and cost effectiveness the right to make changes in these specifications without notice is reserved. Product markings may not be exactly as the ordering codes. Errors and omissions excepted.

Description

Suitable for use with all type 3120-F versions, this module provides a mechanical safety interlock which, according to the option specified, prevents the main switch/circuit breaker mechanism from being reset/switched on. The actuator is intended for use with interlock systems to ensure that machinery cannot be operated without covers and safety guards in place, for instance.

Dimensions

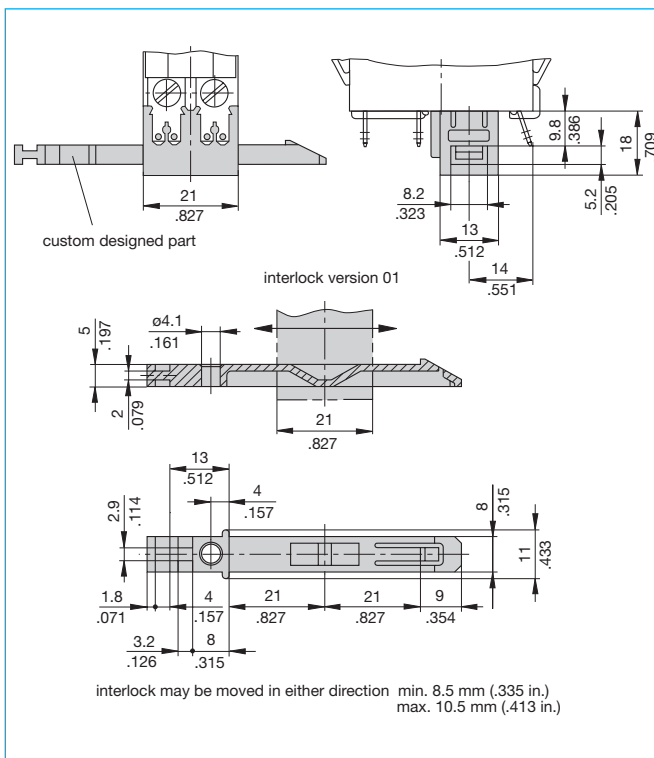

Typical applications

Mechanical monitoring of safety systems, e. g. for garden shredders.

Ordering information

Type No.	
X3120	Module for type 3120-F
Function	
V	mechanical slide interlock module
Module operation	
1	3120 can only be switched on without the interlock fitted
Interlock design	
00	without interlock
01	interlock version 01 (see dimension diagram)
Delivery condition of interlock	
L	interlock supplied separately with the module
M	module factory-fitted with the interlock in its centre position
O	module supplied without interlock
Operating direction of interlock	
0	without interlock, or interlock supplied separately
1	interlock operated from the side near terminals 11, 12k, 12i of the 3120-...
2	interlock operated from the side near terminals 21, 22k, 22i of the 3120-...
Assembly status	
L	module supplied separately
M	module mounted to the circuit breaker
X3120 - V 1 00 0 0 M	ordering example

This is a metric design and millimeter dimensions take precedence ($\frac{\text{mm}}{\text{inch}}$)

All dimensions without tolerances are for reference only. In the interest of improved design, performance and cost effectiveness the right to make changes in these specifications without notice is reserved. Product markings may not be exactly as the ordering codes. Errors and omissions excepted.

Description

Single, two and three pole rocker switch/thermal trip free circuit breakers (S-type TO CBE to EN 60934) of compact design for snap-in panel mounting. Available either with protection on one/both/all poles or, in the case of the double pole version, protection on one pole only. Illumination is optional and there is a choice of rocker colours. Approved to CBE standard EN 60934 (IEC 60934).

Typical applications

Motors, transformers, solenoids, household and office machines, electrical tools, mobile homes, boating, construction vehicles, medical equipment to EN 60601.

Standard current ratings and typical internal resistance values

Current rating (A)	Internal resistance per pole (Ω)	Current rating (A)	Internal resistance per pole (Ω)
0.1	94	4	0.0435
0.2	24	5	0.0325
0.3	12	6	0.0215
0.4	5.30	7	0.0165
0.5	4.20	8	0.0165
0.8	1.50	10	< 0.02
1	0.9	12	< 0.02
1.2	0.80	14	< 0.02
1.5	0.45	15	< 0.02
2	0.27	16	< 0.02
2.5	0.0785	18	< 0.02
3	0.0595	20	< 0.02
3.5	0.0565		

Illumination voltage/power consumption

operating voltage	power consumption	
	filament/neon (B)	LED (G, R, Y)
6 V	60 mA	9 mA
12 V	20 mA	9 mA
24 V	20 mA	9 mA
48 V	20 mA	1.5 mA
115 V	< 1.5 mA	< 1 mA*
230 V	< 1.5 mA	< 1 mA*
415 V	< 1 mA	not available

* single pole version only

Approvals

Authority	Voltage rating	Current rating
VDE (EN 60934)	AC 240/415 V	0.1...20 A single pole 0.1...16 A multipole
	DC 50 V	0.1...8 A single pole 0.1...16 A multipole
	DC 28 V	0.1...20 A single pole
	UL, CSA	AC 250 V; DC 50 V 3 AC 250 V

All dimensions without tolerances are for reference only. In the interest of improved design, performance and cost effectiveness the right to make changes in these specifications without notice is reserved. Product markings may not be exactly as the ordering codes. Errors and omissions excepted.

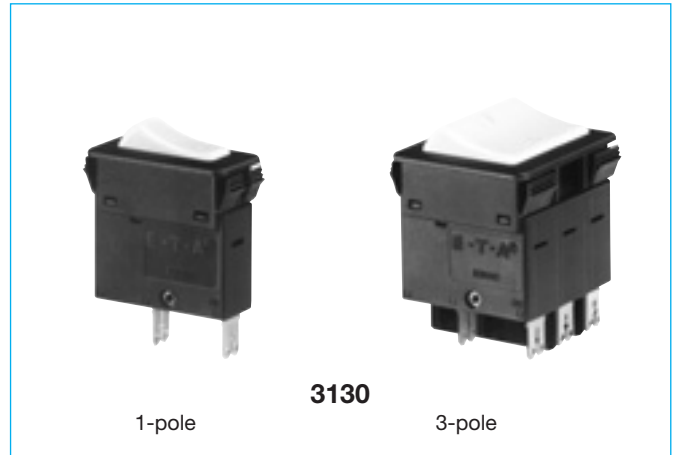

Technical data

For further details please see chapter: Technical Information			
Voltage rating	AC 240 V; 3 AC 415 V; DC 50 V (UL: AC 250 V; 3 AC 250 V; DC 50 V)		
Current ratings	0.1...20 A 1-pole 0.1...16 A 2- and 3-pole		
Typical life	1-pole AC 240 V: 0.1...20 A 30,000 operations at 1 x I _N , inductive DC 50 V: 0.1...4 A 30,000 operations at 1 x I _N , inductive 4.5...16 A 30,000 operations at 1 x I _N , resistive DC 28 V: 4.5...20 A 30,000 operations at 1 x I _N , inductive		
	2-pole AC 240 V: 0.1...16 A 50,000 operations at 1 x I _N , inductive DC 50 V: 0.1...16 A 50,000 operations at 1 x I _N , inductive		
	3-pole 3 AC 415 V: 0.1...16 A 30,000 operations at 1 x I _N , inductive		
Ambient temperature	-30...+60 °C (-22...+140 °F)		
Insulation co-ordination (IEC 60664 and 60664 A)	rated impulse withstand voltage 2.5 kV reinforced insulation in operating area	pollution degree 2	
Dielectric strength (IEC 60664 and 60664A)	test voltage operating area AC 3,000 V current path/current path AC 1,500 V		
Insulation resistance	> 100 MΩ (DC 500 V)		
Interrupting capacity I _{cn}	0.1...2 A 10 x I _N	2.5...20 A 150 A	1-pole
	2.5...16 A 250 A	2.5...12 A 150 A	2-pole
	14 + 16 A 130 A		3-pole
Interrupting capacity (UL 1077)	I _N 0.1...12 A 14...16 A	1- + 2-pole AC 250V/3500A	AC 250V/3500A
		3-pole 3AC 250V/5000A	
		1- + 2-pole DC 50V/2000A	DC 50V/2000A
Degree of protection (IEC 60529/DIN 40050)	operating area IP40 terminal area IP00		
Vibration	5 g (57-500 Hz), ±0.38 mm (10-57 Hz) to IEC 60068-2-6, test Fc 10 frequency cycles/axis		
Shock	1-pole: 25 g (11 ms) 2 + 3-pole: 20 g (11 ms) to IEC 60068-2-27, test Ea		
Corrosion	96 hours at 5 % salt mist, to IEC 60068-2-11, test Ka		
Humidity	240 hours at 95 % RH, to IEC 60068-2-3, test Ca		
Mass	approx. 45 g (three pole) approx. 31 g (double pole) approx. 17 g (single pole)		

Ordering information - 1-pole

Type No.	3130	rocker switch/circuit breaker
Mounting	F	snap in frame
Frame	1	standard
	3	special single pole version
Number of poles	1	single pole, thermally protected
A		1-pole, unprotected**
Frame mounting	0	panel thickness 1-2.5 mm (.039-.099 in) (only 3130-F1...)
	1	panel thickness 1.5-3.2 mm (.059-.126 in)(only 3130-F3.1...)
Terminal design	P7	blade terminals DIN 46244-C-Ms-S (QC 2x.110)
	H7	for terminals 1.1, 2.1 3.1 terminal screws M 3.5 for terminals 1.2, 2.2, 3.1 blade terminals (QC 2x.110)
	N7	blade terminals (QC 2x.110), with shunt terminal
Characteristic curve	T1	thermal, 1.05-1.4 I _N
	Q1	switch, only with terminal design -N7
Switch style	W	rocker
	U	momentary switch function
Switch colour designation		opaque translucent
	01	black 12 white
	02	white 14 red
	04	red 19 green
	09	green 29 black, rocker with green dot
Rocker markings	A	dot (ON position, only with switch colour designation 29)
	Q	"I" and "O" moulded in
Rocker illumination (optional)		
	12 Q Y	white rocker, yellow LED, AC/DC
	14 Q R	red rocker, red LED, AC/DC
	19 Q Y	green rocker, yellow LED, AC/DC
	29 A G	black rocker with dot, green LED
Illumination voltage range* (optional)		
	1	4 - 7 V (G,R,Y)
	2	10 - 14 V (G,R,Y)
	3	20 - 28 V (G,R,Y)
	4	42 - 54 V (R,Y)
	6	90 - 140 V (R,Y)
	7	185 - 275 V (R,Y)
	X	LED, DC 8 - 10 mA ***
Current ratings		0.1...20 A

3130 - F 1 1 0 - P7 T1 - W 12 Q Y 7 - 5 A ordering example

* N/A for non-illuminated version

** unprotected poles have to be ordered with terminal design N7

*** without series resistor and diode, to be selected by customer.

Recommendation:
 4-7 V Rv 0.43 kΩ
 10-14 V Rv 1.1 kΩ
 20-28 V RV 2.7 kΩ
 diode 1N4007

Ordering information - multipole

Type No.	3130	rocker switch/circuit breaker multipole
Mounting	F	snap in frame
Frame	1	standard
Number of poles	2	2-pole, thermally protected
	3	3-pole, thermally protected
	5	2-pole, thermally protected on one pole only
	6	3-pole, thermally protected on two poles only
B		2-pole, unprotected**
C		3-pole, unprotected**
Frame mounting	0	panel thickness 1-2.5 mm (.039-.099 in) (only 3130-F1...)
Terminal design	P7	blade terminals DIN 46244-C-Ms-S (QC 2x.110)
	H7	for terminals 1.1, 2.1 3.1 terminal screws M 3.5; for terminals 1.2, 2.2, 3.1 blade terminals (QC 2x.110)
	N7	blade terminals DIN 46244-C-Ms-S (QC 2x.110), with shunt terminal
Characteristic curve	T1	thermal, 1.05-1.4 I _N
	Q1	switch, only with terminal design -N7
Switch style	W	rocker
	U	momentary switch function
Switch colour designation		opaque translucent
	01	black 12 white
	02	white 14 red
	04	red 19 green
	09	green
Rocker markings	Q	"I" and "O" moulded in
Rocker illumination (optional)		
	B	filament (≤ AC/DC 48 V), neon (≥ AC 115 V)
	G	green LED, DC
	R	red LED, DC
	Y	yellow LED, DC
Illumination voltage range* (optional)		
	1	4 - 7 V (B,G,R,Y)
	2	10 - 14 V (B,G,R,Y)
	3	20 - 28 V (B,G,R,Y)
	4	42 - 54 V (B,R,Y)
	6	90 - 140 V (B)
	7	185 - 275 V (B)
	8	320 - 450 V (B)
Current ratings		0.1...16 A

3130 - F 1 3 0 - P7 T1 - W 12 Q B 7 - 5 A ordering example

* N/A for non-illuminated version

** unprotected poles have to be ordered with terminal design N7

Installation drawing 3130-F1...

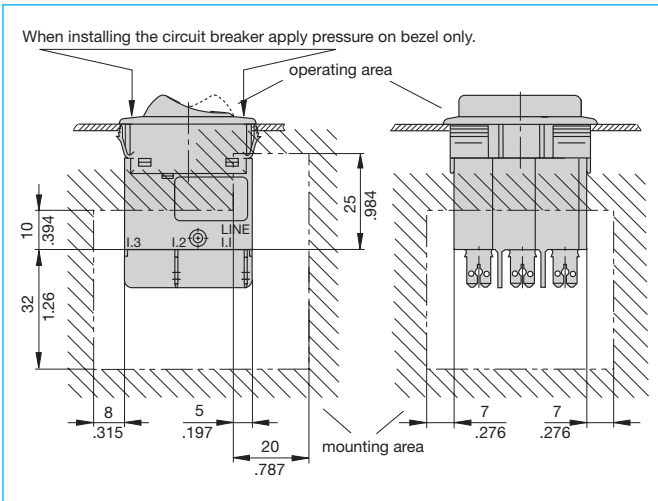

Typical time/current characteristics

Multipole types: all poles symmetrically loaded.
 With single pole overload, thermal tripping will be at approx. $1.54 \times I_N$ with 2-pole devices and at approx. $1.68 \times I_N$ with 3-pole devices.

0.1 2 A

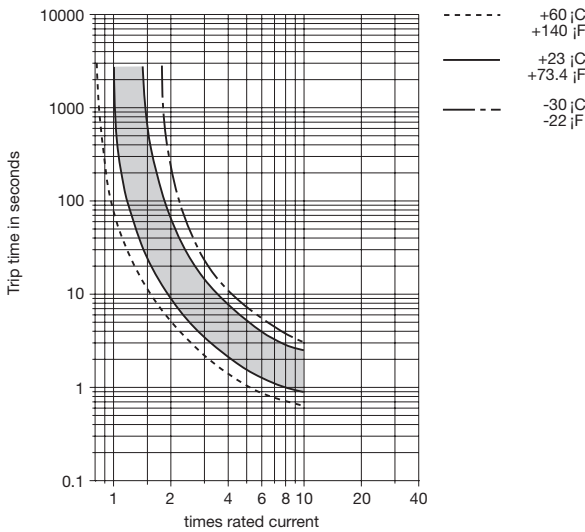

2.5 20 A 1-pole 2.5 16 A 2- and 3-pole

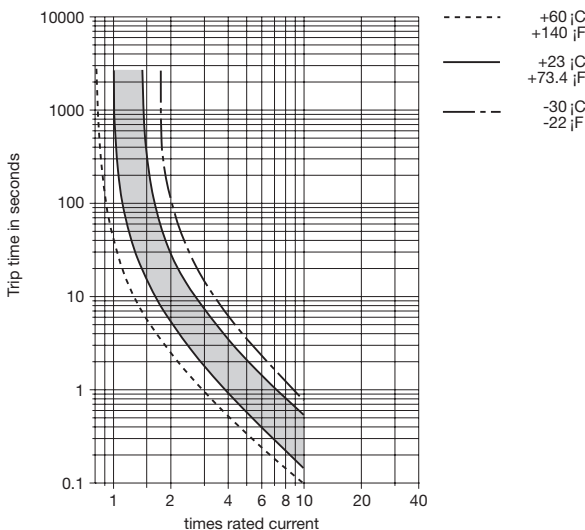

Internal connection diagrams

1-pole

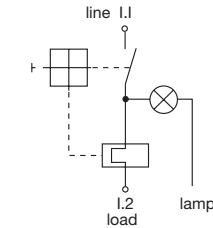

1-pole switch

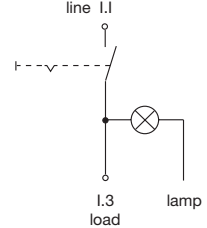

2-pole

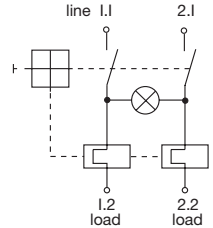

1-pole momentary switch

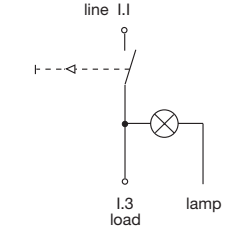

3-pole

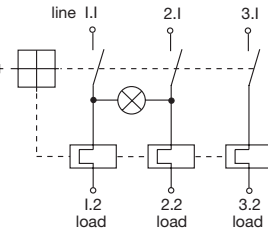

2-pole momentary switch

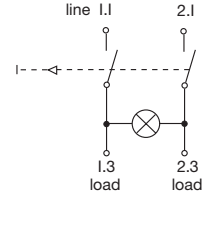

Accessories 3130-F130-...

Splash cover, transparent, for 3-pole version
X 221 258 01 (IP54), comprising bezel Y 306 109 01
 and transparent cover Y 306 108 01

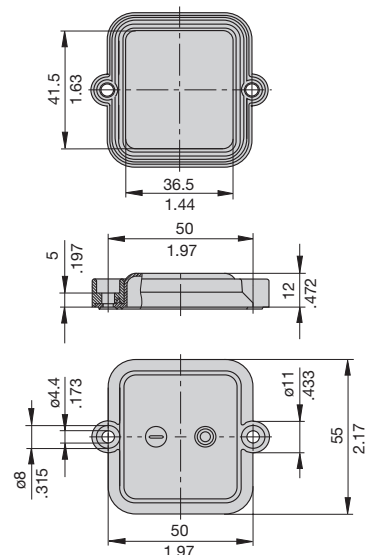

This is a metric design and millimeter dimensions take precedence ($\frac{mm}{inch}$)

The time/current characteristic curve depends on the ambient temperature prevailing. In order to eliminate nuisance tripping, please multiply the circuit breaker current ratings by the derating factor shown below. See also section 9 – Technical information.

Ambient temperature °F	-22	-4	+14	+32	+73.4	+104	+122	+140
°C	-30	-20	-10	0	+23	+40	+50	+60
Derating factor	0.8	0.76	0.84	0.92	1	1.08	1.16	1.24

Description

Single pole rocker switch/thermal trip free circuit breakers (S-type TO CBE to EN 60934) of compact design for snap-in panel mounting. Available either with protection on one/both/all poles or, in the case of the double pole version, protection on one pole only. Illumination is optional and there is a choice of rocker colours. Approved to CBE standard EN 60934 (IEC 60934).

Typical applications

Motors, transformers, solenoids, household and office machines, electrical tools, mobile homes, boating, construction vehicles, medical equipment to EN 60601.

Standard current ratings and typical internal resistance values

Current rating (A)	Internal resistance per pole (Ω)	Current rating (A)	Internal resistance per pole (Ω)
0.1	94	4	0.0435
0.2	24	5	0.0325
0.3	12	6	0.0215
0.4	5.30	7	0.0165
0.5	4.20	8	0.0165
0.8	1.50	10	< 0.02
1	0.9	12	< 0.02
1.2	0.80	14	< 0.02
1.5	0.45	15	< 0.02
2	0.27	16	< 0.02
2.5	0.0785	18	< 0.02
3	0.0595	20	< 0.02
3.5	0.0565		

Illumination voltage/power consumption

operating voltage	power consumption	
	filament/neon (B)	LED (G, R, Y)
6 V	60 mA	9 mA
12 V	20 mA	9 mA
24 V	20 mA	9 mA
48 V	20 mA	1.5 mA
115 V	< 1.5 mA	< 1 mA
230 V	< 1.5 mA	< 1 mA
415 V	< 1 mA	not available

Approvals

Authority	Voltage rating	Current rating
VDE (EN 60934)	AC 240/415 V	0.1...20 A
	DC 50 V	0.1...8 A
	DC 28 V	0.1...20 A
UL, CSA	AC 250 V, DC 50 V	0.1...16 A



3130
water splash protected (IP 66)

Technical data

For further details please see chapter: Technical Information

Voltage rating	AC 240 V; DC 50 V (UL: AC 250 V; DC 50 V)	
Current ratings	0.1...20 A	
Typical life	AC 240 V: 0.1...20 A 30,000 operations at $1 \times I_N$, inductive DC 50 V: 0.1...4 A 30,000 operations at $1 \times I_N$, inductive 4.5...16 A 30,000 operations at $1 \times I_N$, resistive DC 28 V: 4.5...20 A 30,000 operations at $1 \times I_N$, inductive	
Ambient temperature	-30...+60 °C (-22...+140 °F)	
Insulation co-ordination (IEC 60664 and 60664 A)	rated impulse withstand voltage 2.5 kV	pollution degree 2 reinforced insulation in operating area
Dielectric strength (IEC 60664 and 60664A)	test voltage operating area current path/current path	AC 3,000 V AC 1,500 V
Insulation resistance	> 100 M Ω (DC 500 V)	
Interrupting capacity I_{cn}	0.1...2 A 2.5...20 A	10 $\times I_N$ 150 A
Interrupting capacity (UL 1077)	0.1...12 A AC 250V/3,500A DC 50V/2,000A	14...16 A AC 250V/3,500A DC 50V/2,000A
Degree of protection (IEC 60529/DIN 40050)	operating area IP66 terminal area IP00	
Vibration	5 g (57-500 Hz), ± 0.38 mm (10-57 Hz) to IEC 60068-2-6, test Fc 10 frequency cycles/axis	
Shock	25 g (11 ms) to IEC 60068-2-27, test Ea	
Corrosion	96 hours at 5 % salt mist, to IEC 60068-2-11, test Ka	
Humidity	240 hours at 95 % RH, to IEC 60068-2-3, test Ca	
Mass	approx. 17 g	

Internal connection diagrams

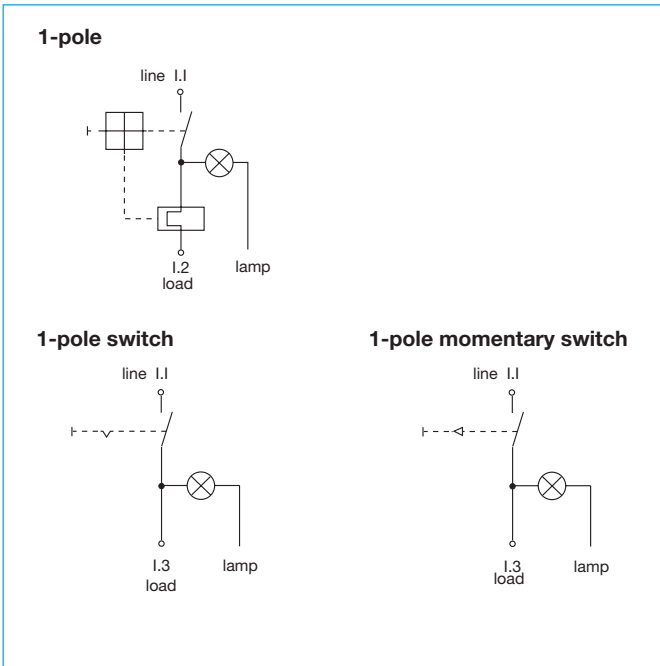

Typical time/current characteristics

0.1 ... 2 A

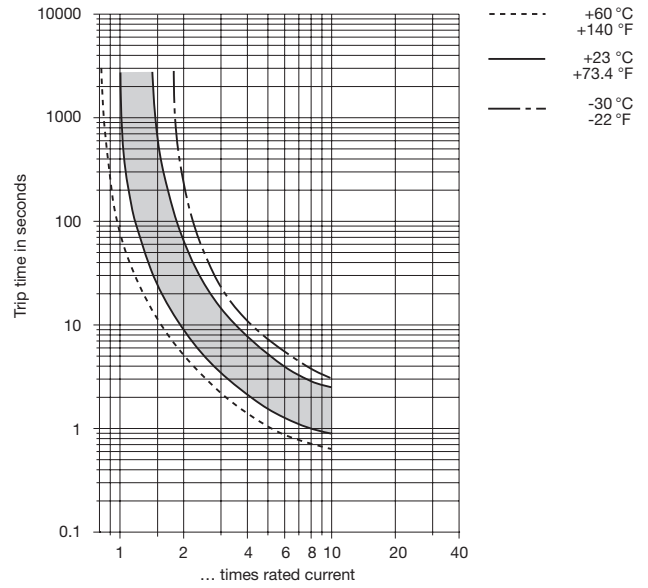

2.5 ... 20 A

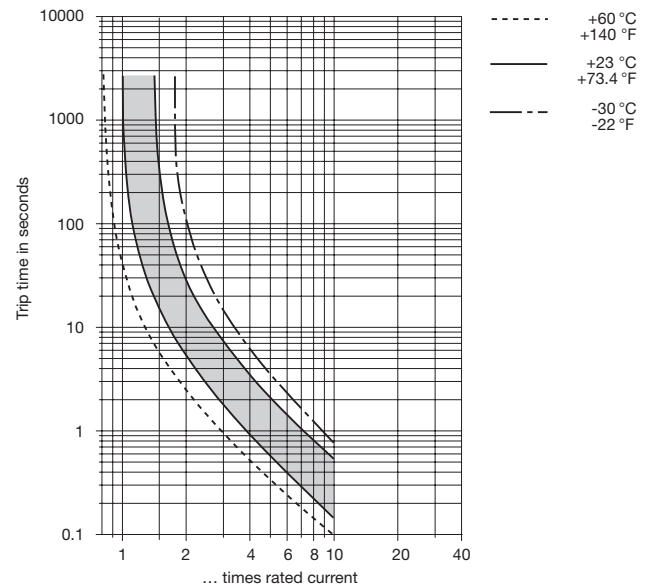

The time/current characteristic curve depends on the ambient temperature prevailing. In order to eliminate nuisance tripping, please multiply the circuit breaker current ratings by the derating factor shown below. See also section 9 – Technical information.

Ambient temperature °F	-22	-4	+14	+32	+73.4	+104	+122	+140
°C	-30	-20	-10	0	+23	+40	+50	+60
Derating factor	0.8	0.76	0.84	0.92	1	1.08	1.16	1.24

Accessories

Rocker X 222 420 ..

How to exchange rockers

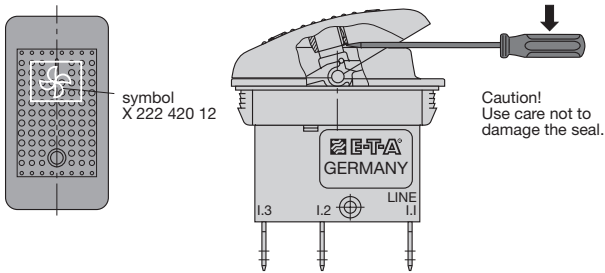

Symbols/legends available

Navigation instruments		X 222 420 14
Music		X 222 420 15
Heating		X 222 420 16
Shower pump		X 222 420 17
		X 222 420 18
Icebox		X 222 420 19
Water for windshield wiper		X 222 420 20
Weigh anchor		X 222 420 21
Drop anchor		X 222 420 22
Search light		X 222 420 23
Autopilot		X 222 420 24
Trim flaps		X 222 420 25
Mast lift		X 222 420 26
Navigation lights (sailing ship)		X 222 420 27
Cockpit light (sailing ship)		X 222 420 28
Deck light (sailing ship)		X 222 420 29
Anchor light (sailing ship)		X 222 420 30

Symbols/legends available

Interior light		X 222 420 01
Anchor light		X 222 420 02
Cockpit light		X 222 420 03
Navigation light		X 222 420 04
VHF radio		X 222 420 05
Refrigerator		X 222 420 06
Anchor		X 222 420 07
Windshield wiper		X 222 420 08
Bilge pump		X 222 420 09
Potable water		X 222 420 10
Horn		X 222 420 11
Ventilation fan		X 222 420 12
Panel light		X 222 420 13

Further symbols upon request.

S00 switch style:

white translucent rocker coated with black lacquer with laser marked symbols that appear in white translucent.

Blanking piece (black) 3130-387012

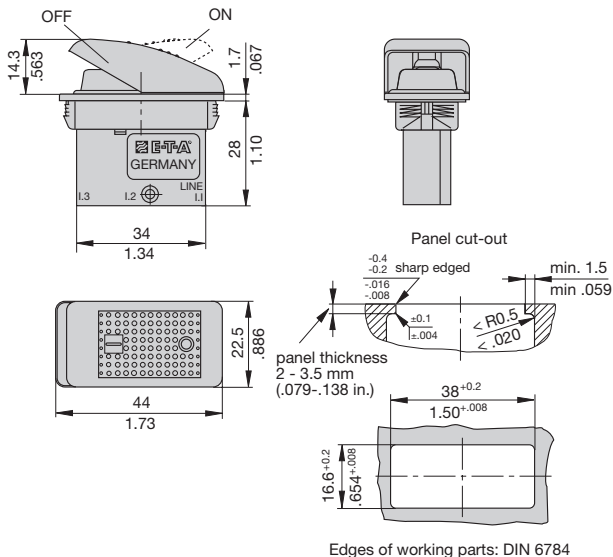

This is a metric design and millimeter dimensions take precedence ($\frac{mm}{inch}$)

All dimensions without tolerances are for reference only. In the interest of improved design, performance and cost effectiveness the right to make changes in these specifications without notice is reserved. Product markings may not be exactly as the ordering codes. Errors and omissions excepted.

Description

Single or two pole rocker switch/thermal circuit breaker (S-type TO).
Rocker illumination is optional and there is a choice of rocker colours.
Reliable trip-free mechanism.
Approved to CBE standard EN 60934 (IEC 60934).

Typical applications

Transformer protection, household appliances and office equipment, floor cleaners, laboratory equipment, medical equipment, in combination with appliance inlet module.

Ordering information - single pole

Type No.	3130	single pole or double pole thermal circuit breaker
Mounting	F	flange mounting, black housing
Design	A	special design, for appliance inlet module
	3	special design
Number of poles	1	single pole, thermally protected
	2	2-pole, thermally protected
	5	2-pole, thermally protected on one pole only
	A	1-pole, unprotected
	B	2-pole, unprotected
Frame mounting	A	supplied without frame
Terminal design	P7	blade terminals 2x2,8x0,8 DIN 46244
	N7	blade terminals 2x2,8x0,8 DIN 46244 only for switch version (curve Q1)
Characteristic curve	T1	thermal 1.05-1.4 I _N
	Q1	switch only, with terminal design -N7
Switch style	W	rocker, one-piece, rounded profile
Switch colour designation		opaque translucent
	01	black
	02	white
	04	red
	09	green
Rocker markings	Q	"I" and "O" moulded in
Rocker illumination		1-pole:
	12 Q Y	white rocker, yellow LED, AC/DC
	14 Q R	red rocker, red LED, AC/DC
	19 Q Y	green rocker, yellow LED, AC/DC
		2-pole:
	B	neon AC/DC
Illumination voltage range	6	90-140 V rated voltage 115 V
	7	185-275 V rated voltage 230 V
Current ratings		0,1...20 A

3130 - F A 2 A - P7 T1 - W 12 Q B 7 - 5 A ordering example

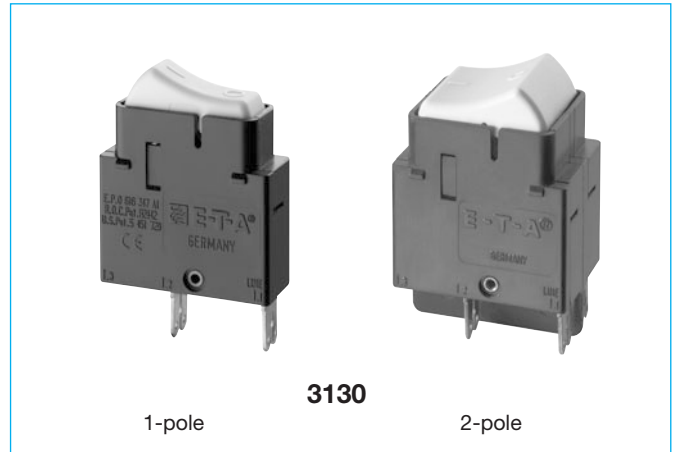

Technical data

Voltage rating	AC 240 V; DC 50 V	
Current ratings	0.1...20 A 1-pole 0.1...16 A 2-pole	
Typical life	1-pole	
AC 240 V:	0.1...20 A	30,000 operations at 1 x I _N , inductive
DC 50 V:	0.1...4 A	30,000 operations at 1 x I _N , inductive
	4.5...16 A	30,000 operations at 1 x I _N , resistive
DC 28 V:	4.5...20 A	30,000 operations at 1 x I _N , inductive
		2-pole
AC 240 V:	0.1...16 A	50,000 operations at 1 x I _N , inductive
DC 50 V:	0.1...16 A	50,000 operations at 1 x I _N , inductive
Ambient temperature	-30...60 °C (-22...+140 °F)	
Insulation co-ordination (IEC 60664 and 60664 A)	rated impulse withstand voltage 2.5 kV	pollution degree 2
	reinforced insulation in operating area*	
Dielectric strength (IEC 60664 and 60664A)	test voltage operating area current path/current path	AC 3,000 V AC 1,500 V
Insulation resistance	>100 MΩ (DC 500 V)	
Interrupting capacity I_{cn}	0.1...2 A 10 x I _N 2.5...20 A 150 A 1-pole 2.5...16 A 250 A 2-pole	
Interrupting capacity UL 1077)	AC 250 V / 3500 A DC 50 V / 2000 A	
Degree of protection (IEC 60529/DIN 40050)	operating area IP40* terminal area IP00	
Vibration*	5 g (57-500 Hz), ±0.38 mm (10-57 Hz) to IEC 60068-2-6, Test Fc 10 frequency cycles/axis	
Shock*	1 pole: 25 g (11 ms) 2 pole: 20 g (11 ms) to IEC 60068-2-27, Test Ea	
Corrosion*	96 hours at 5 % salt mist, to IEC 60068-2-11, Test Ka	
Humidity *	240 hours at 95 % RH, to IEC 60068-2-3, Test Ca	
Mass	approx. 15 g 1-pole approx. 28 g 2-pole	

* mounted in appliance inlet module

All dimensions without tolerances are for reference only. In the interest of improved design, performance and cost effectiveness the right to make changes in these specifications without notice is reserved. Product markings may not be exactly as the ordering codes. Errors and omissions excepted.

Standard current ratings and typical internal resistance values

Current rating (A)	Internal resistance per pole (Ω)	Current (A)	Internal resistance per pole (Ω)
0.1	94	3.5	0.0565
0.2	24	4	0.0435
0.3	12	5	0.0325
0.4	5.30	6	0.0215
0.5	4.20	7	0.0165
0.8	1.50	8	0.0165
1	0.9	10	< 0.02
1.2	0.80	12	< 0.02
1.5	0.45	14	< 0.02
2	0.27	15	< 0.02
2.5	0.0785	16	< 0.02
3	0.0595	20	< 0.02

Approvals

Authority	Voltage rating	Current rating
VDE (EN 60934)	AC 240 V	0.1...20 A single pole
		0.1...16 A 2-pole
	DC 50 V	0.1...8 A single pole
		0.1...16 A 2-pole
UL, CSA	AC 250 V; DC 50 V	0.1...20 A single pole
		0.1...16 A 1- and 2-pole

Dimensions 3130-FA1A-...

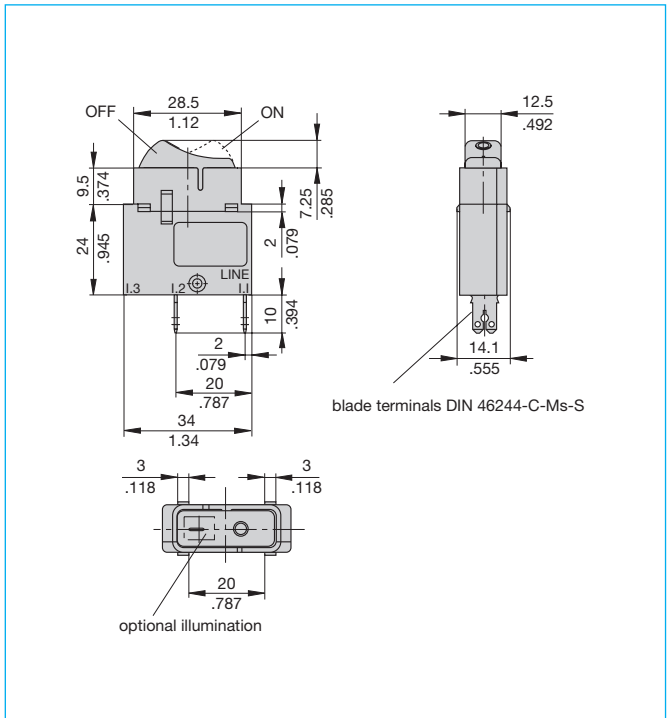

Internal connection diagrams

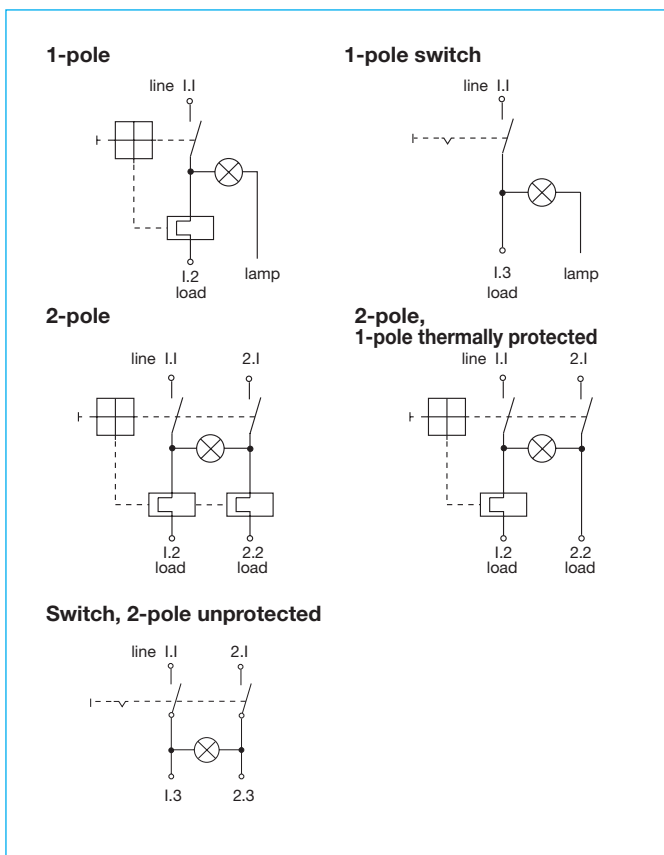

Installation drawing single pole

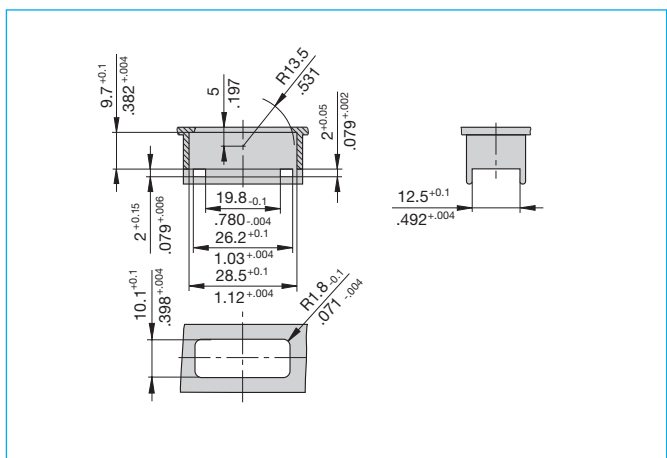

Dimensions 3130-FA2A-...

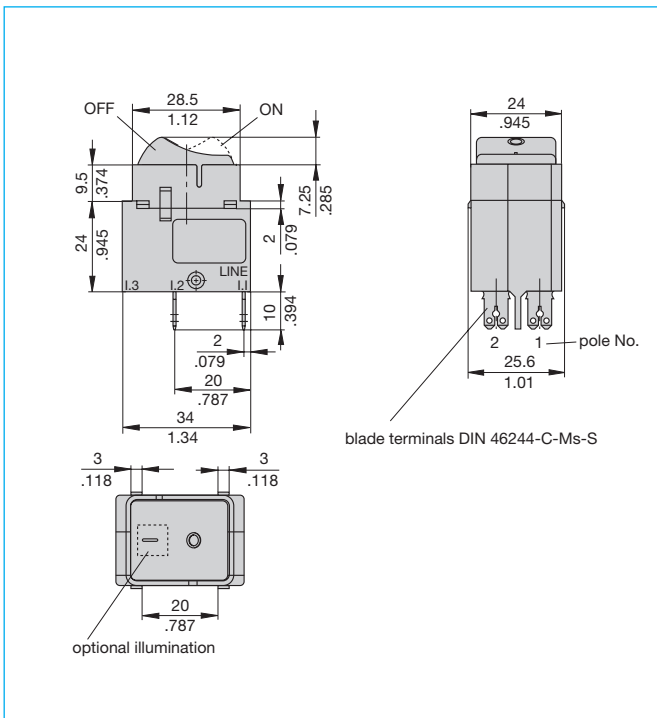

Installation drawing two pole

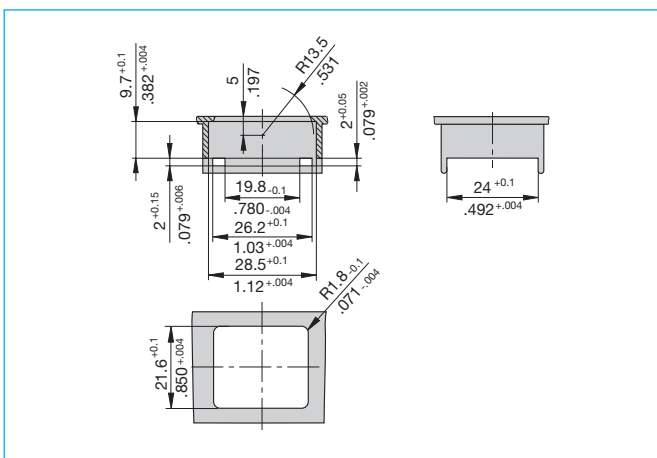

Typical time/current characteristics

Multipole types: all poles symmetrically loaded. With single pole overload, thermal tripping will be at approx. $1.54 \times I_N$ with 2-pole devices.

0.1 ... 2 A

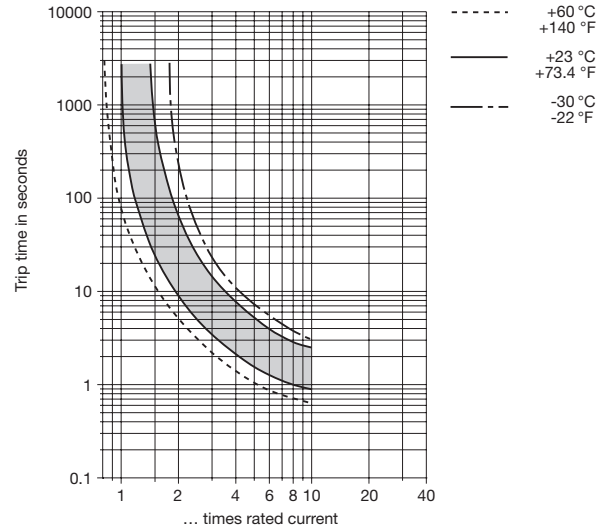

2.5 ... 20 A 1-pole 2.5 ... 16 A 2-pole

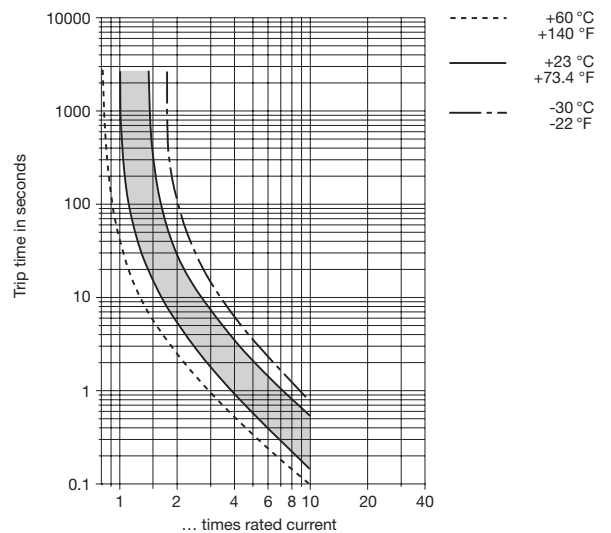

The time/current characteristic curve depends on the ambient temperature prevailing. In order to eliminate nuisance tripping, please multiply the circuit breaker current ratings by the derating factor shown below. See also section 9 – Technical information.

Ambient temperature °F	-22	-4	+14	+32	+73.4	+104	+122	+140
°C	-30	-20	-10	0	+23	+40	+50	+60
Derating factor	0.8	0.76	0.84	0.92	1	1.08	1.16	1.24

Description

Appliance inlet T 70 °C with cut out to accommodate a 2 pole rocker switch/circuit breaker with ON/OFF function.
For 2 pole design only.

Typical applications

Household appliances, laboratory equipment, data processing and communications technology.

Ordering information

Type no.

X3130 Module for type 3130-FA.A

Module Function

A appliance inlet

Design

01 2,5 mm panel thickness, for 2-pole design (number of poles 2, 5 or B)

02 2,0 mm panel thickness, for 2-pole design (number of poles 2, 5 or B)

03 1,5 mm panel thickness, for 2-pole design (number of poles 2, 5 or B)

Accessories

00 without filter

Versions

00 unwired; mounting position 3130: I to plug

01 unwired; mounting position 3130: O to plug (standard)

Assembly status

M module mounted to the circuit breaker 3130-FA.A

X3130 - A 01 00 00 M ordering example

Dimensions X3130-...

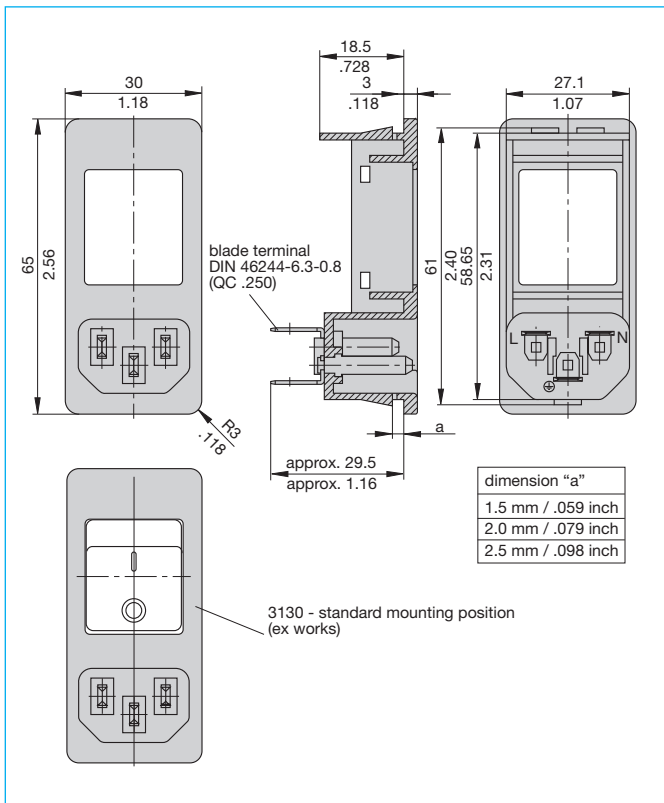

Technical data X3130-...

Voltage rating	AC 250 V
Current rating	10 A (15 A UL/CSA)
Ambient temperature	T 70
Number of poles	L, N + earth
Cable cross section	max. 1.5 mm ²
Degree of protection	protection class I
Mounting	flange mounting
Terminals	blade terminals 6.3x0.8 mm DIN 46244
Mass	approx. 15 g

Approvals

Authority	Voltage rating	Current rating
VDE (EN 60320-1/C14)	AC 250 V	10 A
UL 498; CSA 22.2	AC 250 V	15 A

Accessories

Connector cable

X 222 296 01/ 2 pieces 1.5 mm² (AWG 16), 1 x black and 1 x white

X 222 296 02/ 2 pieces 1.5 mm² (AWG 16), 1 x blue and 1 x brown

Packing quantity: 50 pcs each

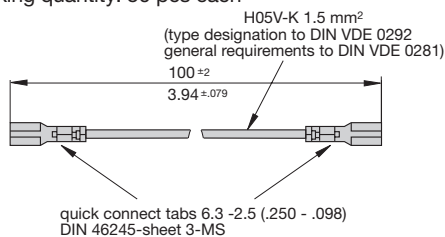

Installation drawing X 3130-...

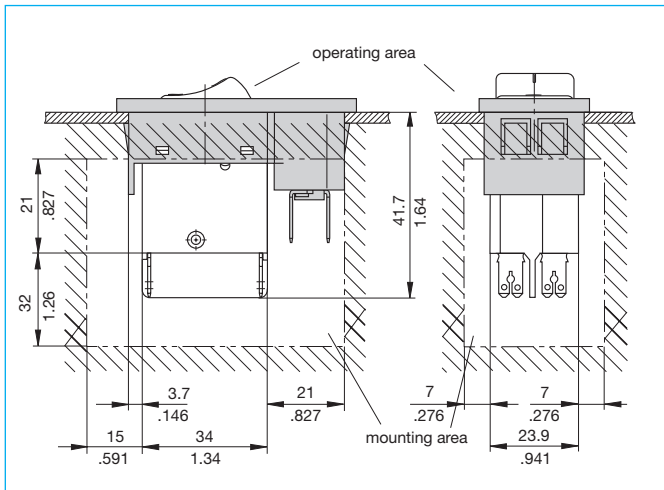

Mounting cut-out X 3130-...

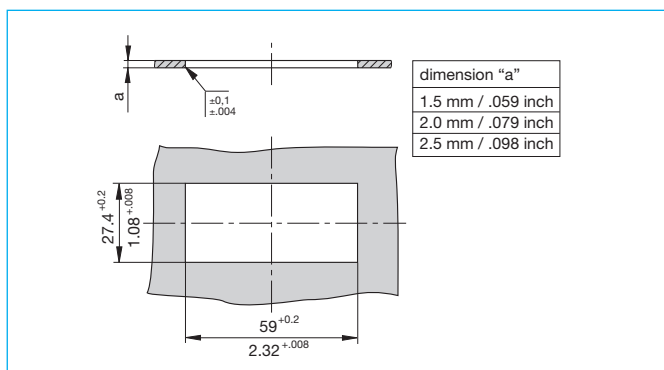

Description

Four pole switch or three pole switch/thermal circuit breaker (S-type TO CBE to EN 60934) with trip-free mechanism and red/green two button operation. Designed for snap-in panel mounting. Integral splash water protection to meet protection degree IP 66 in the operating area (option). Optional with under voltage release module and auxiliary contact module. Complies with CBE standard EN 60934 (IEC 60934).

Typical applications

High-pressure cleaners, shredders, pumps, power saws, electric tools, motors, processing systems.

Ordering information

Type No.	3140 four pole switch or three pole switch/circuit breaker
Mounting	F snap in frame
Frame	1 standard 2 splash water protected version
Number of poles	3 3-pole, thermally protected 7 4-pole, thermally protected on 3 poles only
	C 3-pole, unprotected, switch only D 4-pole, unprotected, switch only
Frame mounting	0 panel thickness 1-6.35 mm (.04-.25 in)
Terminal design	P7 blade terminals 2x2.8x0.8mm(QC 2x.110), DIN 46244-C N7 as P7, but with shunt terminal H7 as P7, but for terminals x.1 terminal screws M3.5 (required with X3140 fitted) G7 as H7, but with shunt terminal
Characteristic curve	T1 thermal Q1 switch only (10,000 operations) *
Switch style	S 2 push buttons (ON/OFF)
Switch colour	GRX green/red
Current rating range	0.1...16 A
3140 - F 1 3 0 - P7 T1 - S GRX - 10 A ordering example	

* only with terminal design N7 or G7

Standard current ratings and typical internal resistance values

Current rating (A)	Internal resistance per pole (Ω)	Current rating (A)	Internal resistance per pole (Ω)
0.1	94	3.5	0.0595
0.2	24	4	0.0435
0.3	12	4.5	0.0325
0.4	5.30	5	0.0325
0.5	4.20	6	0.0215
0.6	2.90	7	0.0165
0.8	1.50	8	0.0125
1	0.9	10	< 0.02
1.2	0.80	12	< 0.02
1.5	0.45	14	< 0.02
2	0.27	15	< 0.02
2.5	0.0785	16	< 0.02
3	0.0595		



3140

Technical data

For further details please see chapter: Technical Information

Voltage rating	3 AC 415 V; DC 50 V		
Current rating range	0.1...16 A		
Typical life	3 AC 415 V: 0.1...14 A	3-pole 10,000 operations at 1 x I _N , inductive	
	15...16 A	10,000 operations at 1 x I _N , resistive	
3 AC 415 V	0.1...14 A	4-pole 10,000 operations at 1 x I _N , inductive	
	15...16 A	10,000 operations at 1 x I _N , resistive	
Ambient temperature	-30...+60 °C (-22...+140 °F)		
Insulation co-ordination (IEC 60664 and 60664A)	rated impulse withstand voltage	pollution degree	2
	2.5 kV		
	reinforced insulation in operating area		
Dielectric strength (IEC 60664 and 60664A)	test voltage	AC 3,000 V	
	operating area	AC 1,500 V	
	between poles (3-pole)	AC 1,500 V	
Insulation resistance	> 100 MΩ (DC 500 V)		
Interrupting capacity I _{cn}	0.1...2 A	10 x I _N	
	2.5...16 A	150 A	
Interrupting capacity (UL 1077)	I _N	U _N	3- and 4-pole
	0.1...16 A	AC 250 V	5,000 A
Degree of protection (IEC 60529/DIN 40050)	operating area IP40		
	(IP66 with water splash protection) terminal area IP00		
Vibration	5 g (57-500 Hz), ±0.38 mm (10-57 Hz) to IEC 60068-2-6, test Fc, 10 frequency cycles/axis		
Shock	20 g (11 ms) to IEC 60068-2-27, test Ea		
Corrosion	96 hours at 5 % salt mist, to IEC 60068-2-11, test Ka		
Humidity	240 hours at 95 % RH, to IEC 60068-2-3, test Ca		
Mass	approx. 68		

Approvals

Authority	Voltage ratings	Current ratings
VDE (EN 60934)	3 AC 415 V	0.1...16 A 3 + 4-pole
UL	AC 250 V	0.1...16 A 3 + 4-pole
CCC	3 AC 415 V	0.1...16 A 3 + 4-pole

All dimensions without tolerances are for reference only. In the interest of improved design, performance and cost effectiveness the right to make changes in these specifications without notice is reserved. Product markings may not be exactly as the ordering codes. Errors and omissions excepted.

Description

A module suitable for all versions of type 3140 to trip the main switch/circuit breaker mechanism in the event of loss of voltage of the connected phases. When the voltage is restored the switch must be reset to reconnect the load, thereby avoiding the safety hazards associated with automatic re-starting of machinery.

Note: Basic unit 3140-... must be fitted with -H7 or -G7 screw terminals.

Typical applications

Machines such as power tools, industrial equipment and domestic appliances where automatic restart after restoration of power could be dangerous (EU Machinery Directive).

Ordering information

Type No.	
X3140	Module for type 3140
Function	
U	undervoltage release module
Terminal design	
00	standard (without separate connections)
01	one blade terminal 2.8x0.8 (QC .110)
02	two blade terminals 2.8x0.8 (QC .110)
03	as 01, with flying lead 0.5mm ² (l = 250 mm) and female connector 6.3x1 DIN 46247-MS
Voltage ratings	
00	AC 400 V 50/60 Hz
03	DC 24 V
09	AC 230 / 240 V 50/60 Hz
Assembly status	
M	module mounted to the circuit breaker
X3140 - U 00 00 M	ordering example

Technical data

Voltage ratings	AC 400 V 50/60 Hz; AC 230 V; DC 24 V
Voltage tolerance	+10%/-15%
Current consumption	approx. 2.0 mA
Release values	$0.2 \times U_N < U < 0.7 \times U_N$ (at a rated voltage of AC 400 V the device may release at 280 V and must release at 80 V)
Release delay	$t < 20$ ms
Latch-in values	$\geq 85 \% U_N$
Ambient temperature	-30...+60 °C (-22...+140 °F)
Vibration	5 g (57-500 Hz) ± 0.38 mm (10-57 Hz) to IEC 60068-2-6, test Fc 10 frequency cycles/axis
Shock	20 g (11 ms) to IEC 60068-2-27, test Ea
Corrosion	48 hours at 5 % salt mist, to IEC 60068-2-11, test Ka
Humidity	240 hours at 95% RH to IEC 60068-2-30, test Ca
Mass	approx. 90 g (complete assembly)

Dimensions

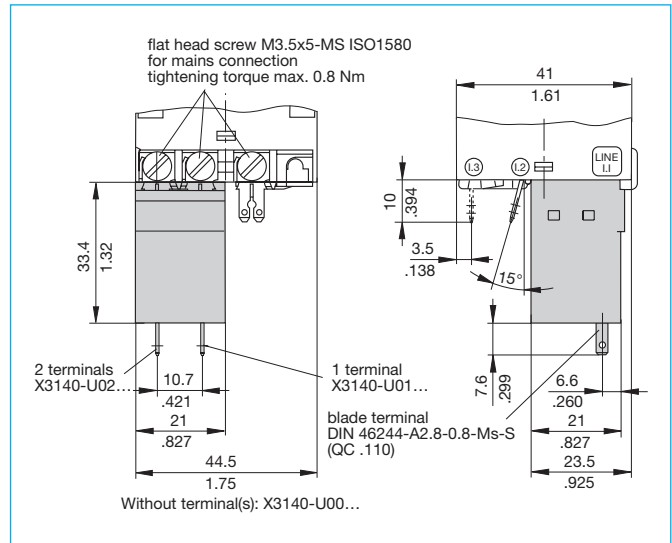

Internal connection diagrams

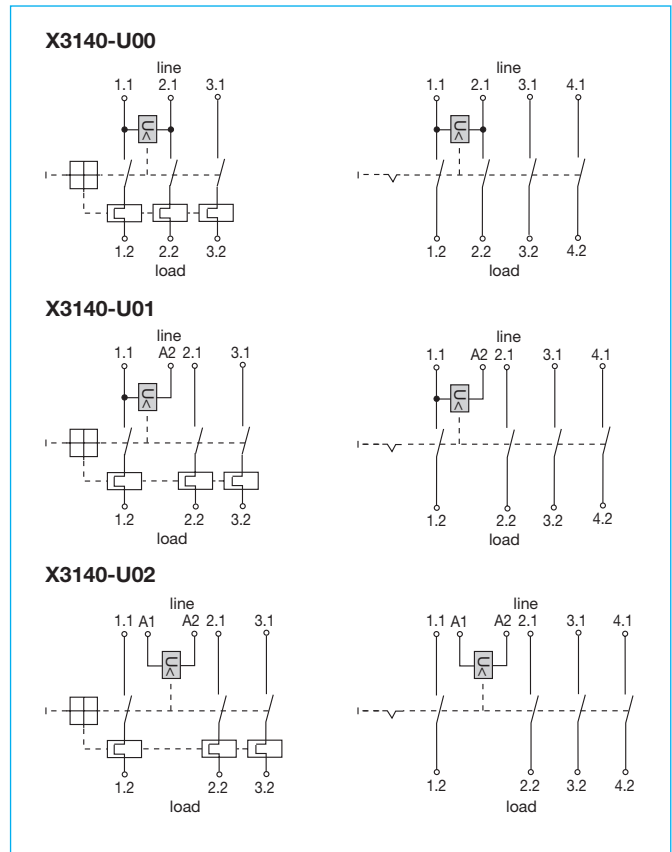

Approvals (complete circuit breaker/module assembly)

Authority	Voltage ratings
VDE (EN 60934)	AC 400 V; AC 230/240 V; DC 24 V

This is a metric design and millimeter dimensions take precedence ($\frac{\text{mm}}{\text{inch}}$)

All dimensions without tolerances are for reference only. In the interest of improved design, performance and cost effectiveness the right to make changes in these specifications without notice is reserved. Product markings may not be exactly as the ordering codes. Errors and omissions excepted.

Description

A module supplied factory fitted to type 3140-F to provide electrically separate changeover contacts which operate as the main contacts open/close. Ideally suited to status signalling and sequence switching.

Typical applications

Monitoring of the switching position of the circuit breaker or any connected load.

Dimensions

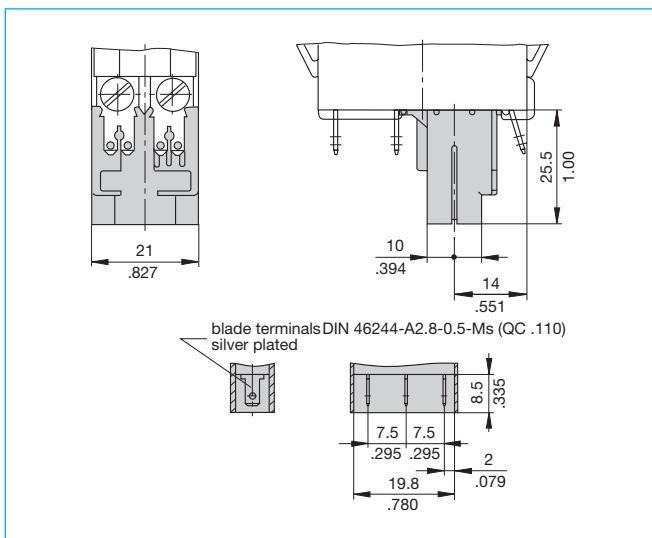

Ordering information

Type No.			
X3120 Module for type 3120 and type 3140			
Function			
S auxiliary contact module			
Contact configuration			
0 change-over contact			
Terminal design			
1 blade terminals 2.8 x 0.5 (QC .110), silver plated			
Contact rating			
AC		DC (not approved)	
Voltage rating	Current rating	Voltage rating	Current rating
A 10 V-250 V	0.1...4 A	12 V	0.1...4 A
		24 V	0.1...4 A
		60 V	0.1...1 A
		110 V	0.1...0.5 A
		220 V	0.1...0.25 A
B 5 V-250 V	0.05...1 A	5 V-250 V	0.05...1 A
Assembly status			
M module mounted to circuit breaker 3140-...			
X3120 - S 0 1 A M ordering example			

Internal connection diagram

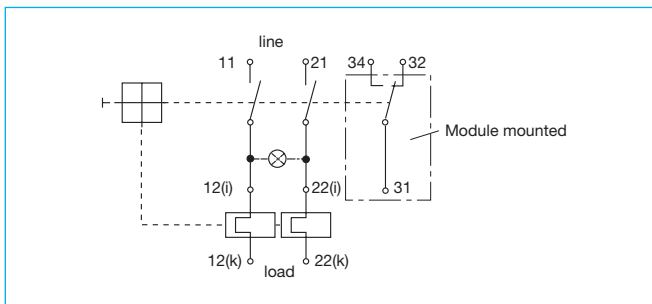

Technical data

Voltage rating	AC 250 V; DC 220 V
Current rating	0.1...4 A / 0.05...1 A
Typical life	50,000 operations
Ambient temperature	-30...+60 °C (-22...140 °F)
Dielectric strength (IEC 60664 and 60664A)	test voltage between main and auxiliary circuit
Insulation resistance	AC 3,000 V
Insulation resistance	> 100 MΩ (DC 500 V)
Vibration	6 g (type X3120-S...A) 8 g (type X3120-S...B) (57-500 Hz), ±0.46 mm (10-57 Hz) to IEC 60068-2-6, test Fc 10 frequency cycles/axis
Shock	15 g (11 ms), type X3120-S...A 20 g (11 ms), type X3120-S...B to IEC 60068-2-27, test Ea
Corrosion	96 hours at 5 % salt mist, to IEC 60068-2-11, test Ka
Humidity	240 hours at 95 % RH to IEC 60068-2-30, test Ca
Mass	approx. 38 g (complete assembly)

Approvals (complete circuit breaker/module assembly)

Authority	Voltage ratings	Current ratings
VDE (EN 60934)	AC 250 V; DC 28 V	0.05...4 A
UL, CSA	AC 250 V	0.05...4 A

This is a metric design and millimeter dimensions take precedence ($\frac{\text{mm}}{\text{inch}}$)

All dimensions without tolerances are for reference only. In the interest of improved design, performance and cost effectiveness the right to make changes in these specifications without notice is reserved. Product markings may not be exactly as the ordering codes. Errors and omissions excepted.

Description

Single pole high performance thermal circuit breaker, with push-to-reset tease free, trip-free snap action mechanism (R-type TO CBE to EN 60934). Designed for threadneck panel mounting and for applications with a high fault current switching requirement. Approved to CBE standard EN 60934 (IEC 60934).

Typical applications

Motors, transformers, solenoids, battery chargers, power supplies, appliances, machinery, extra low voltage systems.

Ordering information

Type No.	Description
4130	single pole thermal circuit breaker
Mounting	
G	threadneck panel mounting
Threadneck design	
2	M12x1, knurled nut (bulk shipped)
4	M12x1, hex nut and knurled nut (bulk shipped)
Number of poles	
1	single pole, thermally protected
Actuator configuration	
1	black push button
Terminal design	
K4	terminal M6x8 screw and washer bulk shipped
Characteristic curve	
M1	medium delay
Current ratings	
20... 70 A	
4130 - G 2 1 1 - K4 M1 - 20 A ordering example	

Standard current ratings and typical internal resistance values

Current rating (A)	Internal resistance (Ω)	Current rating (A)	Internal resistance (Ω)
20	< 0.02	40	< 0.01
25	< 0.02	50	< 0.01
30	< 0.02	60	< 0.01
35	< 0.02	70	< 0.01

Approvals

Authority	Voltage ratings	Current ratings
VDE (EN 60934)	AC 240 V; DC 50 V	20...70 A
UL	AC 240 V; AC 120 V; DC 50 V	20...80 A



4130-...

Technical data

For further details please see chapter: Technical Information			
Voltage rating	AC 240 V; DC 50 V		
Current rating range	20...70 A		
Typical life	AC 240 V: 20...70 A 100 operations at $2 \times I_N$, inductive 500 operations at $2 \times I_N$, resistive DC 50 V: 20...80 A 500 operations at $2 \times I_N$, inductive		
Ambient temperature	-30...+60 °C (-22...+140 °F)		
Insulation co-ordination (IEC 60664)	rated impulse withstand voltage	pollution degree	
	2.5 kV	2 (reinforced insulation in the mounting area)	
Dielectric strength operating area	test voltage	AC 3,000 V	
Insulation resistance	> 100 MΩ (DC 500 V)		
Interrupting capacity I_{cn}	800 A		
Interrupting capacity (UL 1077)	I_N	U_N	
	20...70 A	AC 240 V	1,000 A
	20...60 A	AC 120 V	3,500 A
	70 A	AC 120 V	2,000 A
	20...50 A	DC 50 V	3,500 A
	60...70 A	DC 50 V	2,000 A
Degree of protection (IEC 60529/DIN 40050)	operating area IP40 terminal area IP00		
Vibration	8 g (57-500 Hz) ± 0.61 mm (10-57 Hz) to IEC 60068-2-6, test Fc 10 frequency cycles/axis		
Shock	25 g (11 ms) to IEC 60068-27, test Ea		
Corrosion	96 hours at 5 % salt mist, to IEC 60068-2-11, test Ka		
Humidity	240 hours at 95 % RH to IEC 60068-2-3, test Ca		
Mass	approx. 55 g		

Dimensions

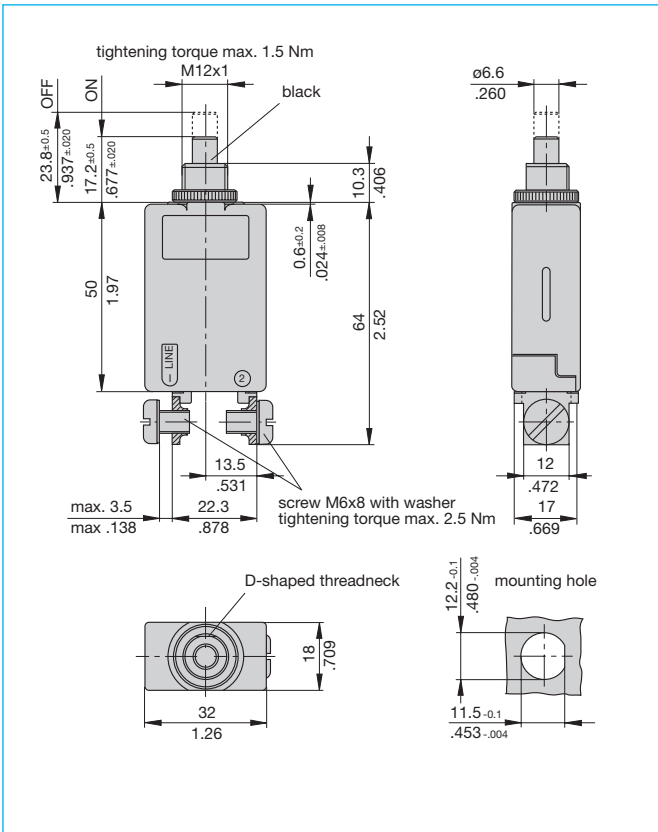

Typical time/current characteristics

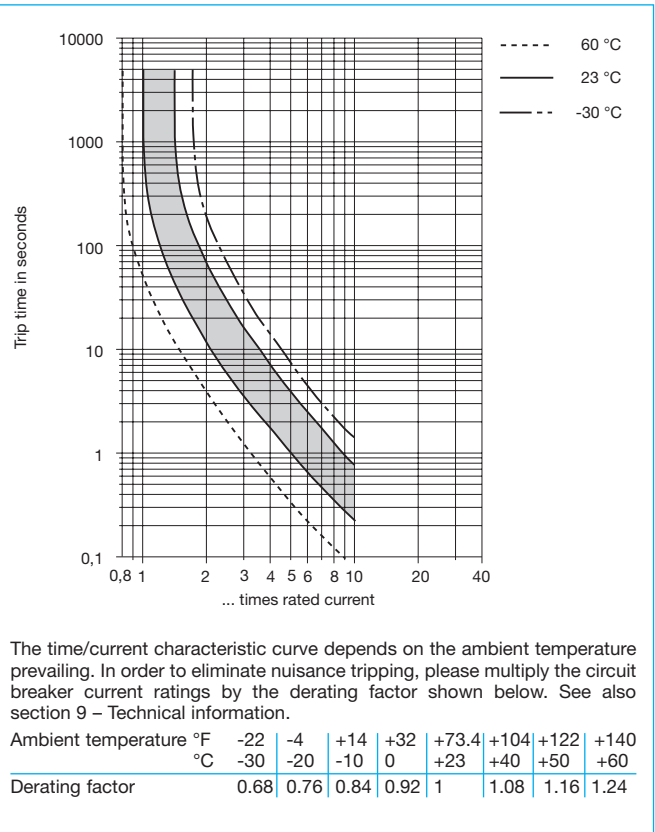

Installation drawing

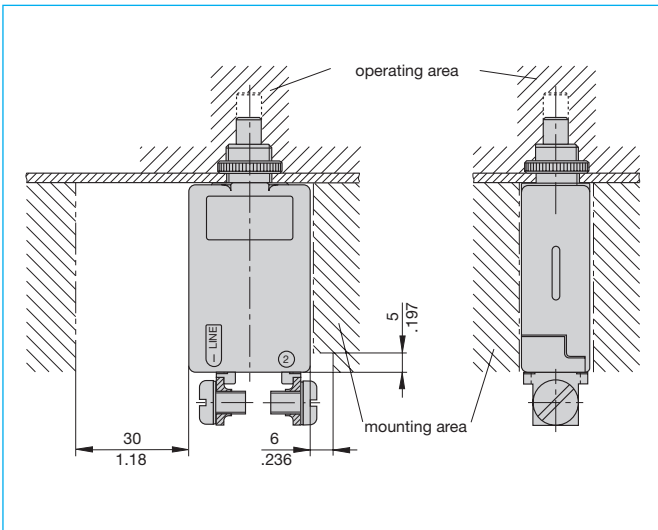

Accessories

Hex nut with splash cover, black
 X 201 296 01 without O ring (IP64)
 X 200 801 03 with O ring (IP66)
 Hex nut with splash cover, transparent
 X 200 801 08 with O ring (IP66)

Water splash cover, transparent with knurled nut and O ring (IP64)
 X 210 663 01



Separate hardware
 Hex nut Y 300 116 02

Knurled nut
 Y 302 065 01

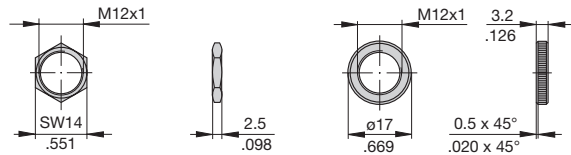

Internal connection diagram

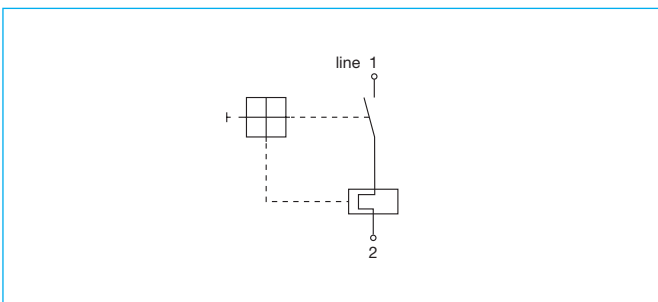

This is a metric design and millimeter dimensions take precedence ($\frac{\text{mm}}{\text{inch}}$)

All dimensions without tolerances are for reference only. In the interest of improved design, performance and cost effectiveness the right to make changes in these specifications without notice is reserved. Product markings may not be exactly as the ordering codes. Errors and omissions excepted.