



Rectangular I/O Connectors

- NFC-UTE C 93-425
- According to MIL-C-24308
- Layouts: 9, 15, 25, 37 and 50
- High reliability
- More than 5000 mating and unmating cycles
- Contact resistance: 5 mΩ max.
- Solder and removable crimp contacts

Technical Characteristics

MATERIAL		GENERAL CHARACTERISTICS					
Shell	Plated steel	Housing	E	A	B	C	D
Insulator	PBT (15%) UL 94 V0	Number of contacts	9	15	25	37	50
Pin & socket body	Brass	Pitch between contacts	2.77 mm (25, 37 & 50 contacts)				
Socket wires	Copper alloy	Pitch between rows	2.84 mm				
Plastic hood	ABS, UL 94 V0	Crimp termination	AWG 26-28 (0.093 to 0.14 mm ²)				
Metallized plastic hood	Metallized ABS, UL 94 V0	ENVIRONMENTAL CHARACTERISTICS					
Metallized hood	Aluminium alloy	Temperature range	-55 °C, + 125 °C				
PLATING		Dry heat	1000h at +125 °C				
Terminations and contact areas	Au/Ni	Salt spray	GS series : 48h		GSD series : 500h		
Shell	GS: tinned shell	Damped heat	56 days (40 °C, relative humidity: 90-95 %)				
	GSD: zinc yellow-chromate plated shell	MECHANICAL CHARACTERISTICS					
ELECTRICAL CHARACTERISTICS		Contact retention	40N min (max displacement: 0.3 mm)				
Working Voltage	300 VAC	Mating and unmating cycles	5000				
Current rating	7.5 A	Vibrations and shocks	no discontinuity 20 ns				
Dielectric withstanding voltage	1000 V _{rms}	• Sinusoidal vibrations	10/2000 Hz, 1.5 mm, 20g				
Electrical continuity (shell to shell)*	2 mΩ typical	• Shocks	50 g				
Contact resistance	5 mΩ max	INSULATOR RETENTION IN HOUSING					
	(standard value 8 mΩ max)	Housing	E	A	B	C	D
Insulation resistance	5.10 ³ MΩ max	Number of contacts	9	15	25	37	50
		Min retention	53N	80N	124N	180N	233N
* Only for tin plated shells with dimples							

Ordering Information

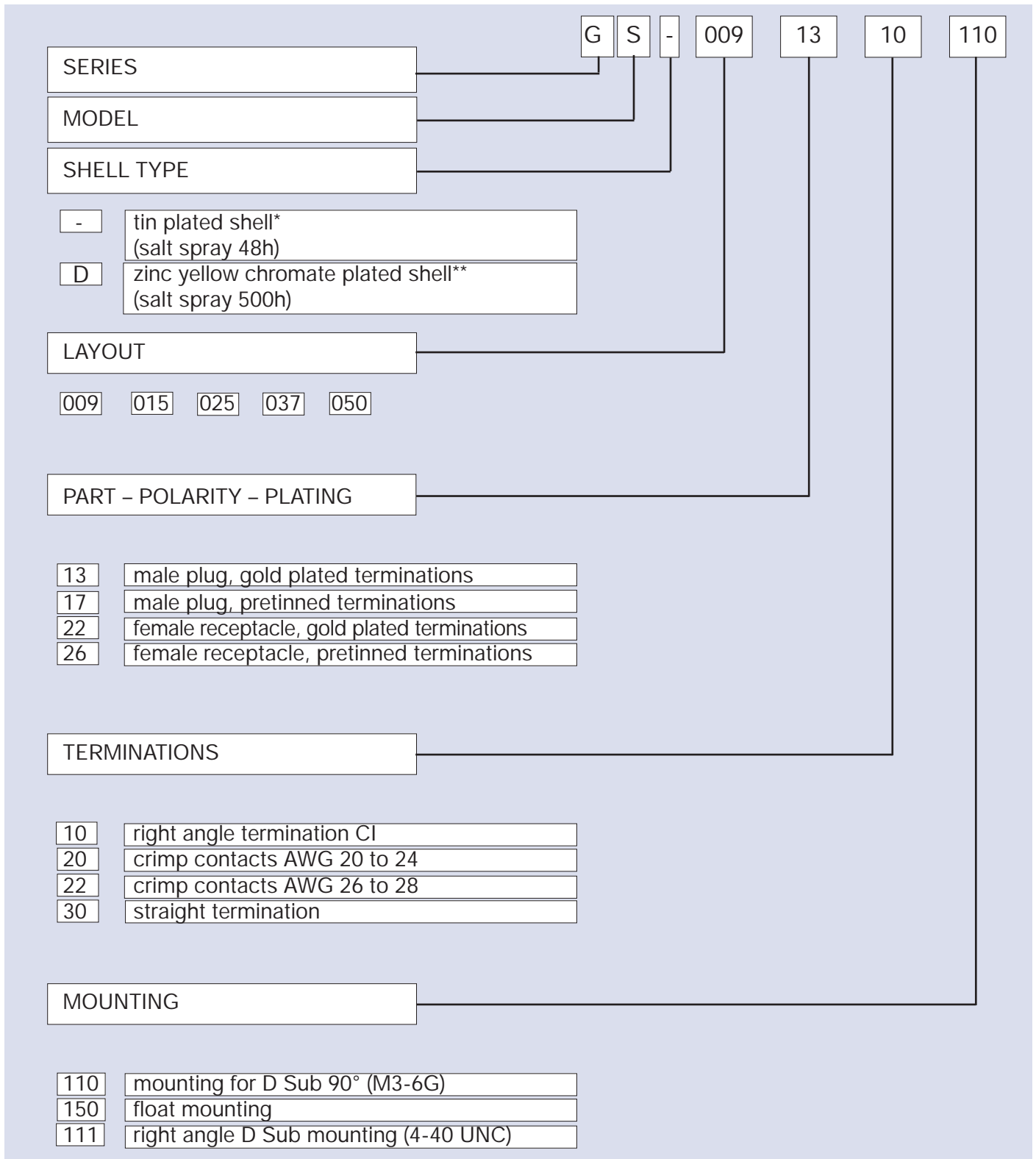

* male plug with dimples
 ** male plug without dimples

The other accessories are sold separately
 Sealed connectors: consult us.

Dimensions: 90° PC tail plugs

Pin \varnothing 1.02

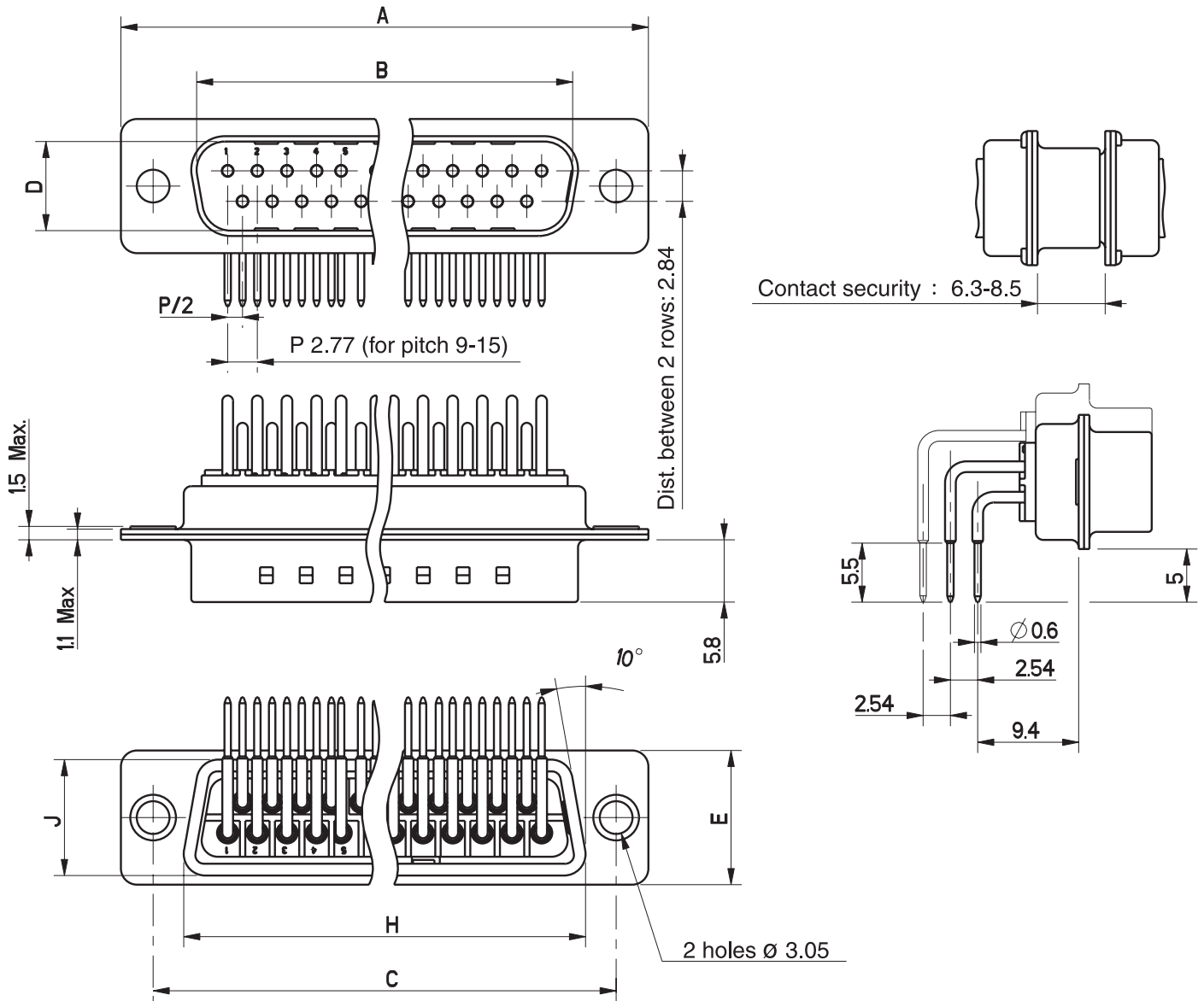

Part Number	No. of contacts	Dimensions (mm)						
		A ± 0.2	B ± 0.2	C ± 0.2	D ± 0.2	E ± 0.2	H ± 0.2	J ± 0.2
GS-009..10...	9	30.7	16.9	25	8.4	12.3	19.3	10.8
GS-015..10...	15	39.1	25.2	33.3	8.4	12.3	27.5	10.8
GS-025..10...	25	52.9	38.9	47.05	8.4	12.3	41.3	10.8
GS-037..10...	37	69.3	55.4	63.5	8.4	12.3	57.7	10.8
GS-050..10...	50	66.7	52.8	61.1	11.2	15.3	55.3	13.6

Dimensions are in mm

Dimensions: 90° PC tail receptacles

Socket \varnothing 1.02

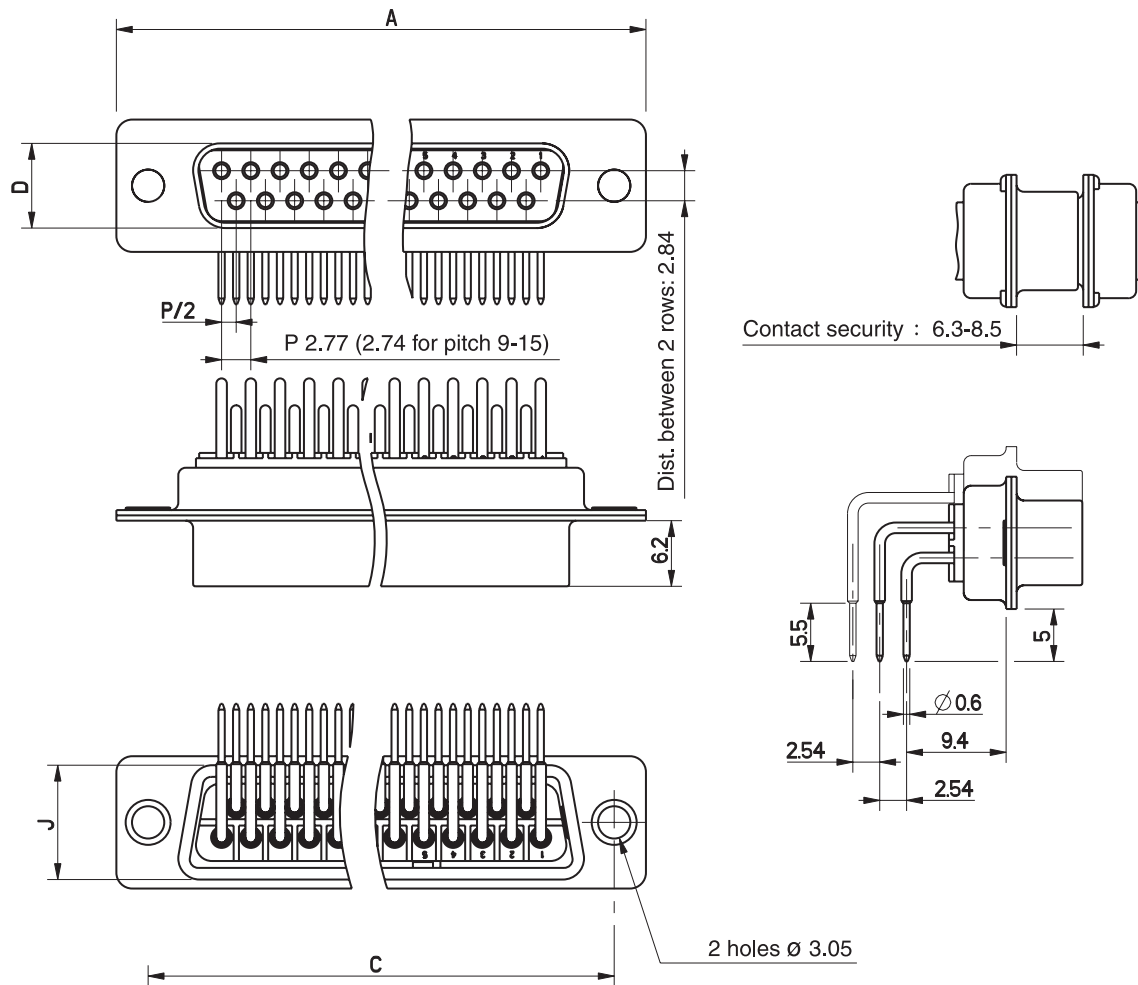

Part Number	No. of contacts	Dimensions (mm)						
		A ± 0.2	B ± 0.2	C ± 0.2	D ± 0.2	E ± 0.2	H ± 0.2	J ± 0.2
GS-009..10...	9	30.7	16.2	25	7.8	12.3	19.3	10.8
GS-015..10...	15	39.1	24.7	33.3	7.8	12.3	27.5	10.8
GS-025..10...	25	52.9	38.4	47.05	7.8	12.3	41.3	10.8
GS-037..10...	37	69.3	54.7	63.5	7.8	12.3	57.7	10.8
GS-050..10...	50	66.7	52.3	61.1	10.8	15.3	55.3	13.6

Dimensions are in mm

Dimensions: straight PC tail plugs

Pin \varnothing 1.02

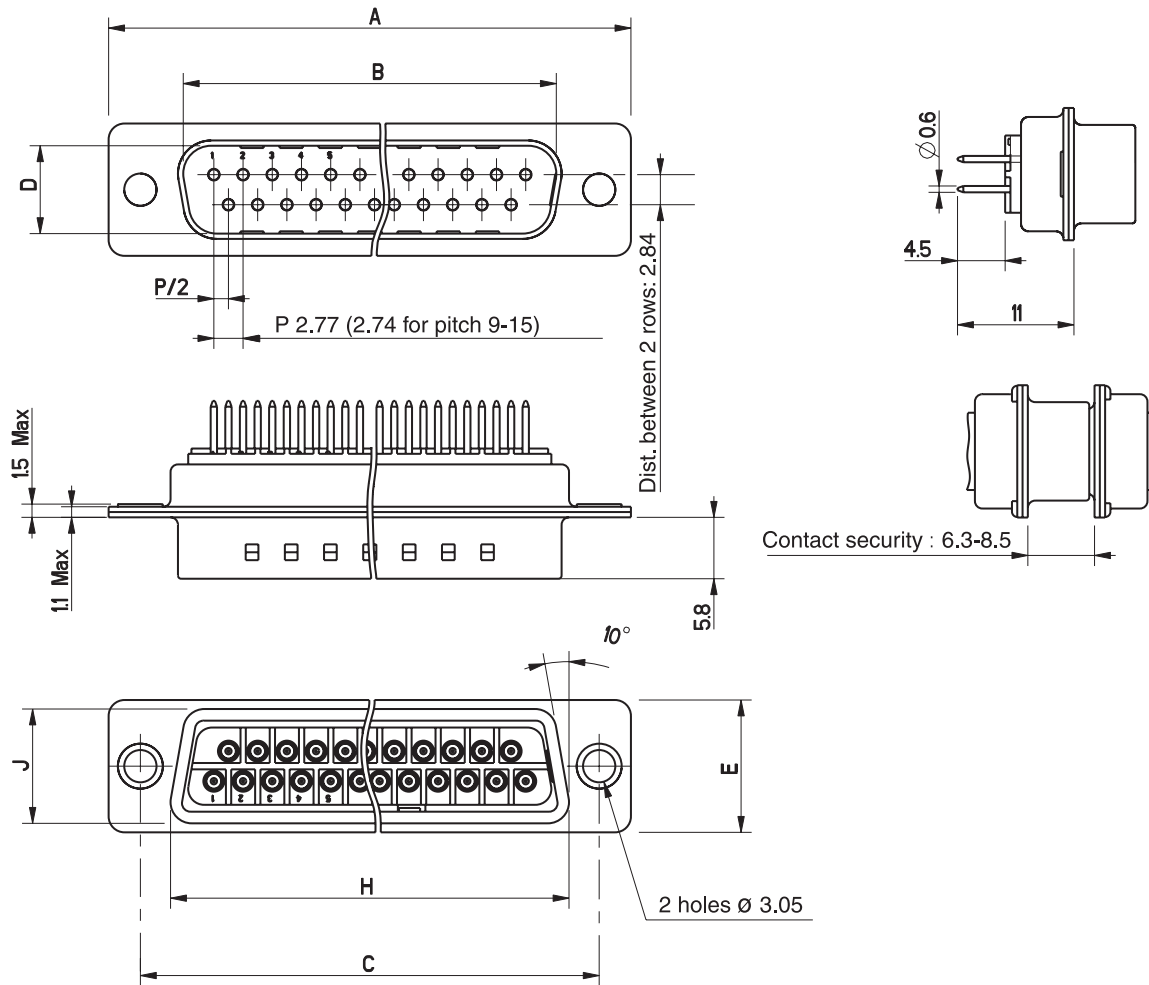

Part Number	No. of contacts	Dimensions (mm)						
		A	B	C	D	E	H	J
		± 0.2	± 0.2	± 0.2	± 0.2	± 0.2	± 0.2	± 0.2
GS-009..30...	9	30.7	16.9	25	8.4	12.3	19.3	10.8
GS-015..30...	15	39.1	25.2	33.3	8.4	12.3	27.5	10.8
GS-025..30...	25	52.9	38.9	47.05	8.4	12.3	41.3	10.8
GS-037..30...	37	69.3	55.4	63.5	8.4	12.3	57.7	10.8
GS-050..30...	50	66.7	52.8	61.1	11.2	15.3	55.3	13.6

Dimensions are in mm

Dimensions: straight PC tail receptacles

Socket \varnothing 1.02

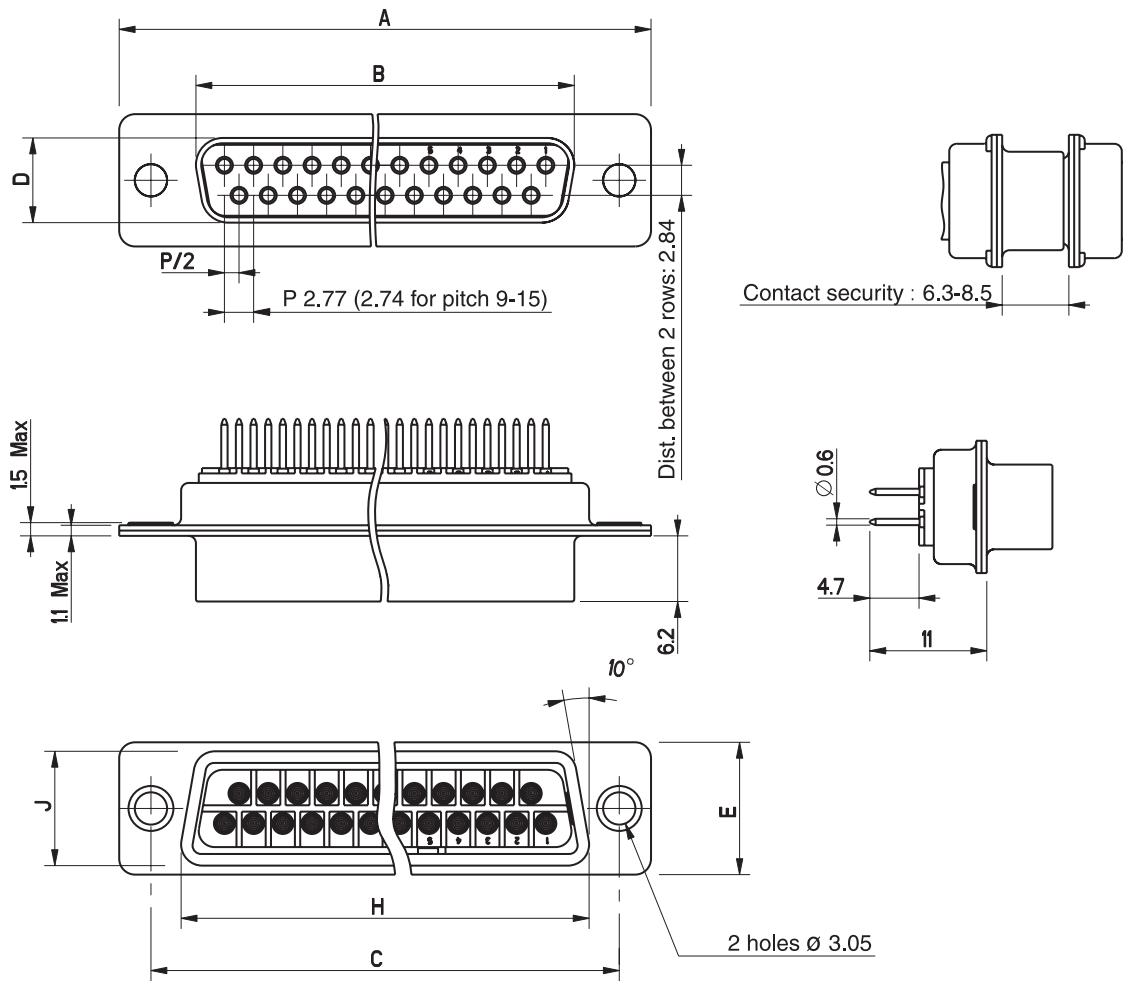

Part Number	No. of contacts	Dimensions (mm)						
		A	B	C	D	E	H	J
		± 0.2	± 0.2	± 0.2	± 0.2	± 0.2	± 0.2	± 0.2
GS-009..30...	9	30.7	16.2	25	7.8	12.3	19.3	10.8
GS-015..30...	15	39.1	24.7	33.3	7.8	12.3	27.5	10.8
GS-025..30...	25	52.9	38.4	47.05	7.8	12.3	41.3	10.8
GS-037..30...	37	69.3	54.7	63.5	7.8	12.3	57.7	10.8
GS-050..30...	50	66.7	52.3	61.1	10.8	15.3	55.3	13.6

Dimensions are in mm

Dimensions: crimp terminations

Pin \varnothing 1.02

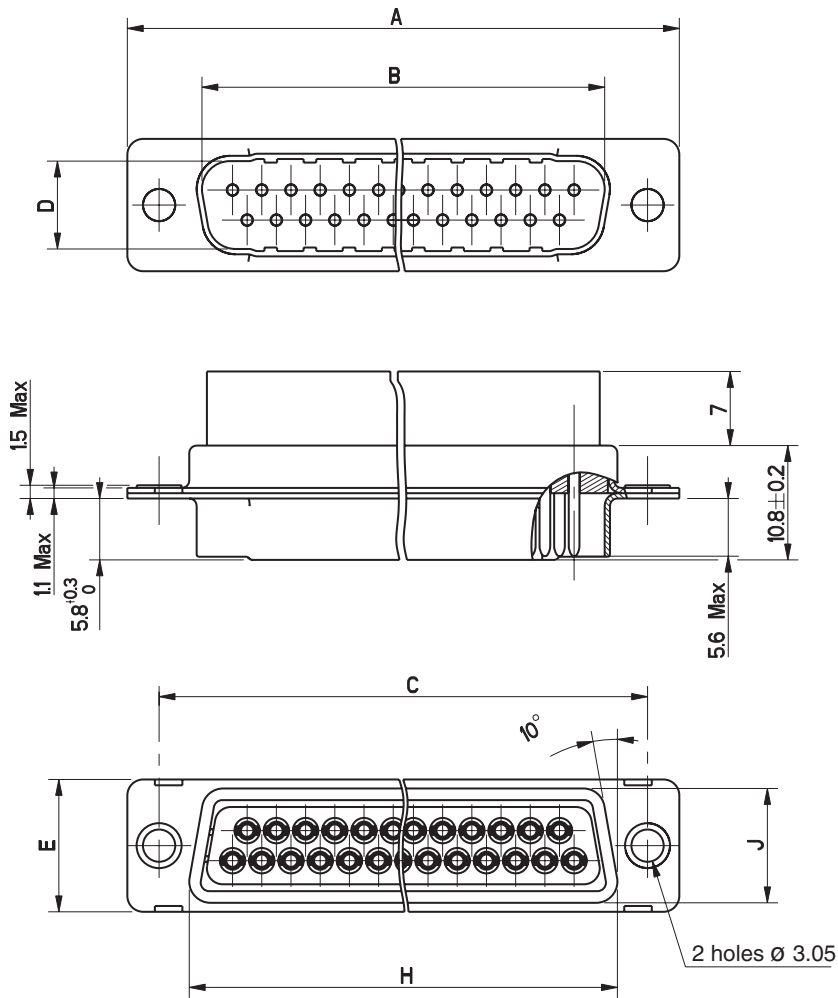

Part Number	No. of contacts	Dimensions (mm)						
		A ± 0.2	B ± 0.2	C ± 0.2	D ± 0.2	E ± 0.2	H ± 0.2	J ± 0.2
GS-009..20...	9	30.8	16.8	25	8.3	12.5	19.3	10.8
GS-009..22...	9	30.8	16.8	25	8.3	12.5	19.3	10.8
GS-015..20...	15	39.1	25.1	33.3	8.3	12.5	27.5	10.8
GS-015..22...	15	39.1	25.1	33.3	8.3	12.5	27.5	10.8
GS-025..20...	25	53	38.9	47	8.3	12.5	41.3	10.8
GS-025..22...	25	53	38.9	47	8.3	12.5	41.3	10.8
GS-037..20...	37	69.3	55.3	63.5	8.3	12.5	57.7	10.8
GS-037..22...	37	69.3	55.3	63.5	8.3	12.5	57.7	10.8
GS-050..20...	50	67	52.7	61.1	11	15.4	55.3	13.6
GS-050..22...	50	67	52.7	61.1	11	15.4	55.3	13.6

Dimensions are in mm

Dimensions: crimp terminations receptacles

Socket \varnothing 1.02

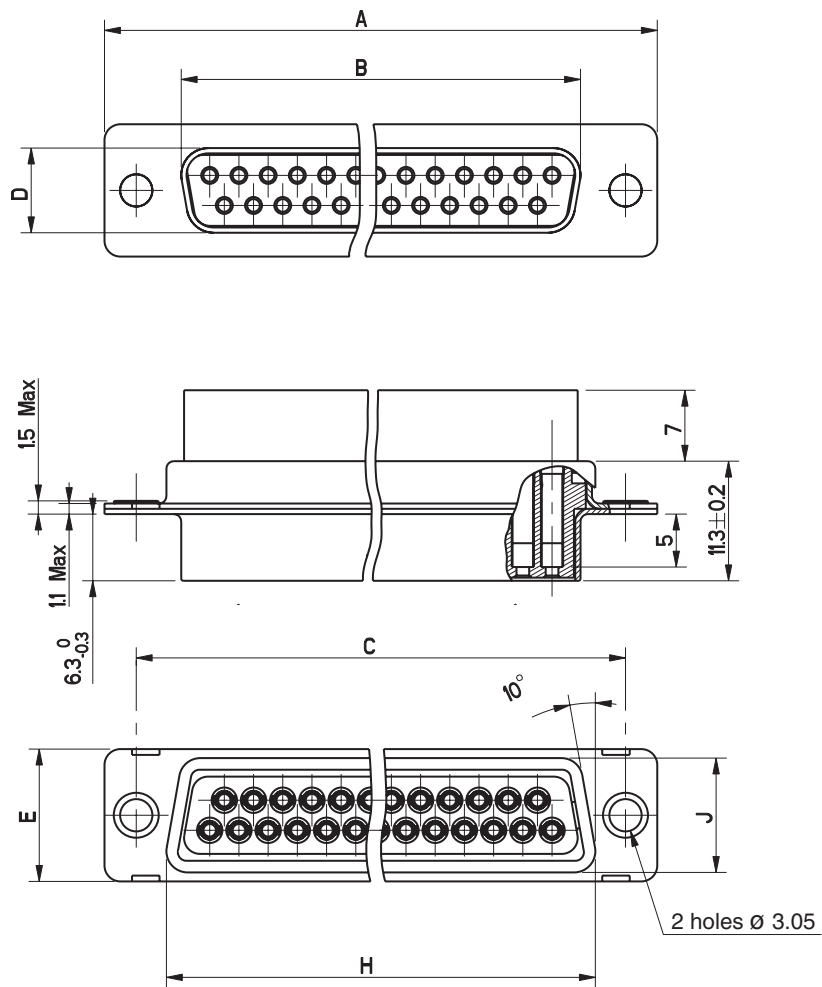

Part Number	No. of contacts	Dimensions (mm)						
		A ± 0.2	B ± 0.2	C ± 0.2	D ± 0.2	E ± 0.2	H ± 0.2	J ± 0.2
GS-009..20...	9	30.8	16.4	25	8	12.5	19.3	10.8
GS-009..22...	9	30.8	16.4	25	8	12.5	19.3	10.8
GS-015..20...	15	39.1	24.7	33.3	8	12.5	27.5	10.8
GS-015..22...	15	39.1	24.7	33.3	8	12.5	27.5	10.8
GS-025..20...	25	53	38.5	47	8	12.5	41.3	10.8
GS-025..22...	25	53	38.5	47	8	12.5	41.3	10.8
GS-037..20...	37	69.3	54.9	63.5	8	12.5	57.7	10.8
GS-037..22...	37	69.3	54.9	63.5	8	12.5	57.7	10.8
GS-050..20...	50	67	52.5	61.1	10.8	15.4	55.3	13.6
GS-050..22...	50	67	52.5	61.1	10.8	15.4	55.3	13.6

Dimensions are in mm

Mounting

Float Mounting

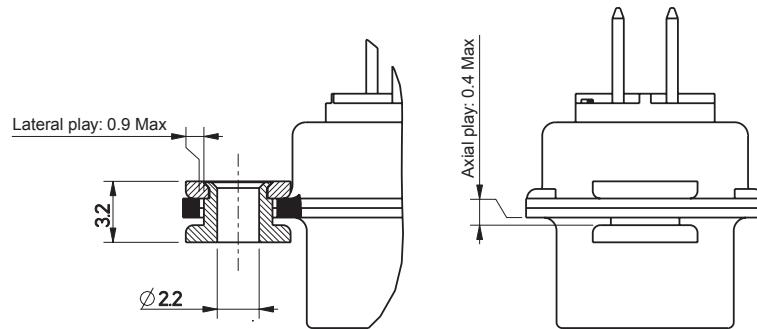

Ref. GS- - - - - 150

Bracket and screw for D SUB 90° - 9 to 37

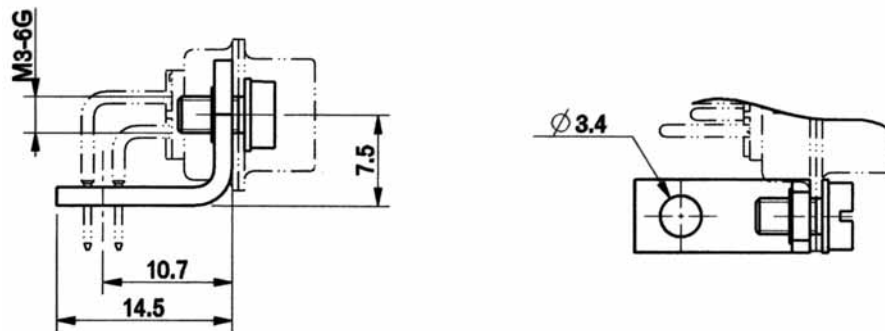

Ref. GS- - - - - 110

Bracket and female screw lock for D SUB 90° - 9 to 37

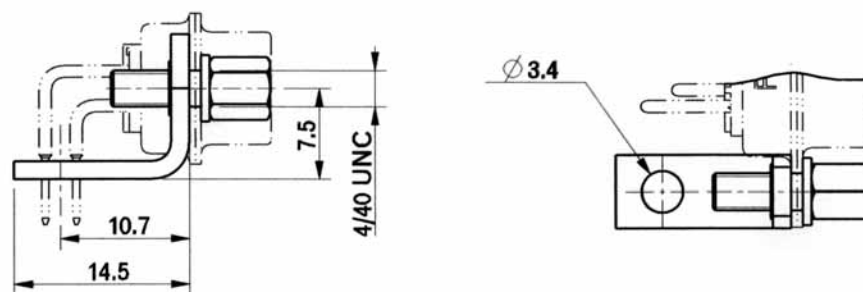

Ref. GS- - - - - 111

Dimensions are in mm

Hoods with screw locks

Plastic, 38mm screws

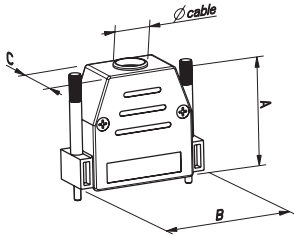

Part Number	Dimensions (mm)			Ø Cable
	A	B	C	
GS-009 300	31	31.5	15.2	8.5
GS-015 300	35	40	15.2	8.5
GS-025 300	38	53.5	15.2	11
GS-037 300	40	70	15.2	11
GS-050 300	40	67.5	18.2	12

Plastic 18mm screws

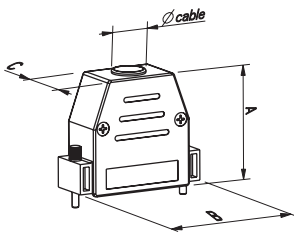

Part Number	Dimensions (mm)			Ø Cable
	A	B	C	
GS-009 301	31	31.5	15.2	8.5
GS-015 301	35	40	15.2	8.5
GS-025 301	38	53.5	15.2	11
GS-037 301	40	70	15.2	11
GS-050 301	40	67.5	18.2	12

Metallized plastic 38mm screws

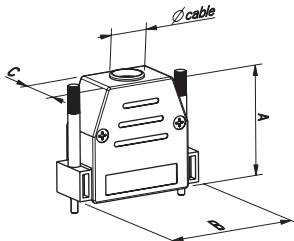

Part Number	Dimensions (mm)			Ø Cable
	A	B	C	
GS-009 302	31	31.5	15.2	8.5
GS-015 302	35	40	15.2	8.5
GS-025 302	38	53.5	15.2	11
GS-037 302	40	70	15.2	11
GS-050 302	40	67.5	18.2	12

Metallized plastic 18mm screws

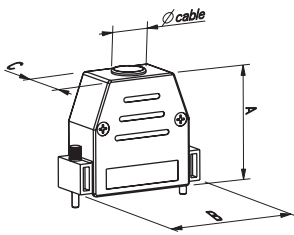

Part Number	Dimensions (mm)			Ø Cable
	A	B	C	
GS-009 303	31	31.5	15.2	8.5
GS-015 303	35	40	15.2	8.5
GS-025 303	38	53.5	15.2	11
GS-037 303	40	70	15.2	11
GS-050 303	40	67.5	18.2	12

Diecast hood with screw locks

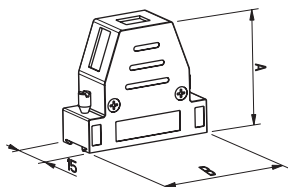

Part Number	Dimensions (mm)	
	A	B
GS-009 304	38	31
GS-015 304	35	39.5
GS-025 304	43	53

Diecast hood with side cable output and screw locks

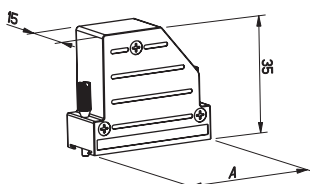

Part Number	Dimensions (mm)
	A
GS-009 305	31
GS-015 305	39.3
GS-025 305	53

Accessories

Crimp sleeve

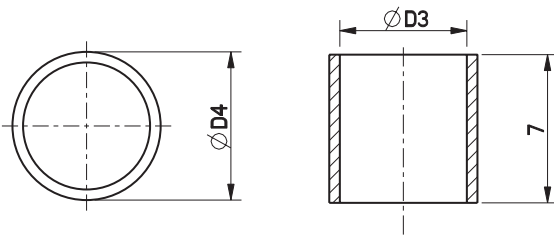

Part Number	Dimensions (mm)	
	Ø D3	Ø D4
GS-060 307	6	7
GS-065 307	6.5	7.5
GS-075 307	7.5	8.5
GS-080 307	8	9
GS-100 307	10	11
GS-105 307	10.5	11.5
GS-110 307	11	12
GS-115 307	11.5	12.5
GS-120 307	12	13
GS-140 307	14	15

Crimp flange

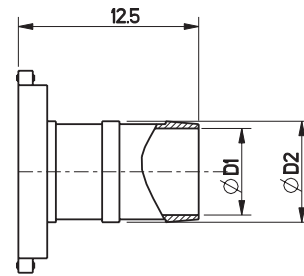

Part Number	Dimensions (mm)	
	Ø D1	Ø D2
GS-030 306	3	4
GS-035 306	3.5	4.5
GS-045 306	4.5	5.5
GS-050 306	5	6
GS-060 306	6	7
GS-070 306	7	8
GS-076 306	7.6	8.6
GS-080 306	8	9
GS-090 306	9	10

Blind plug for diecast hood

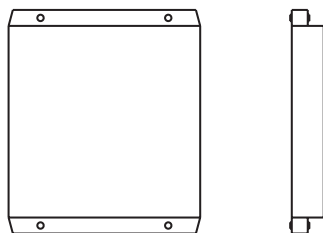

Part Number	Number of contacts
GS-937 308	9 to 37
GS-050 308	50

Accessories

Female screw lock

Male screw lock without hood

YELLOW-CHROMATE FINISH	
Part Number	Dimensions (mm)
GS-002 120	10
GS-002 121	11
GS-002 122	13.2
GS-002 123	16
GS-002 124	18.2
GS-002 125	22

TIN PLATED FINISH	
Part Number	Dimensions (mm)
GS-002 130	10
GS-002 131	11
GS-002 132	13.2
GS-002 133	16
GS-002 134	18.2
GS-002 135	22

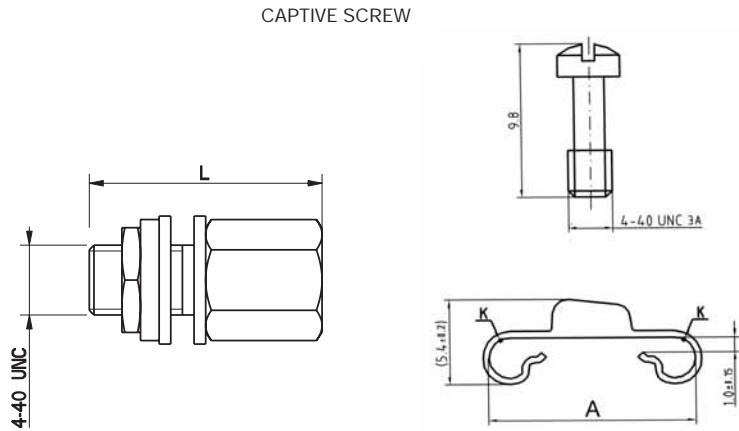

Part Number	Number of contacts	Dimensions
GS-002 937 115	9 to 37	13,2
GS-002 050 115	50	15,7

Crimp tool

Locating plug



Ref. M 22520/201



Ref. M 22520/208

Dust caps



Contact extraction tool

Part Number	Number of female contacts
GS-009-311	9
GS-015-311	15
GS-025-311	25
GS-037-311	37
GS-050-311	50



Ref. S-090

Part Number	Number of male contacts
GS-009-312	9
GS-015-312	15
GS-025-312	25
GS-037-312	37
GS-050-312	50

Board preparation details for straight or bent terminations

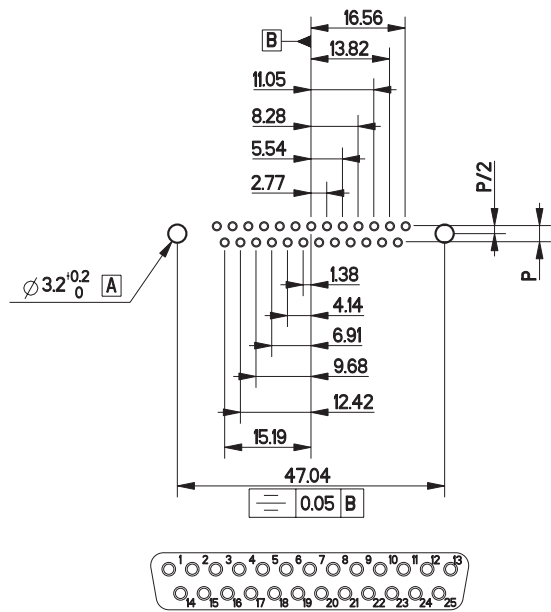

25 Contacts

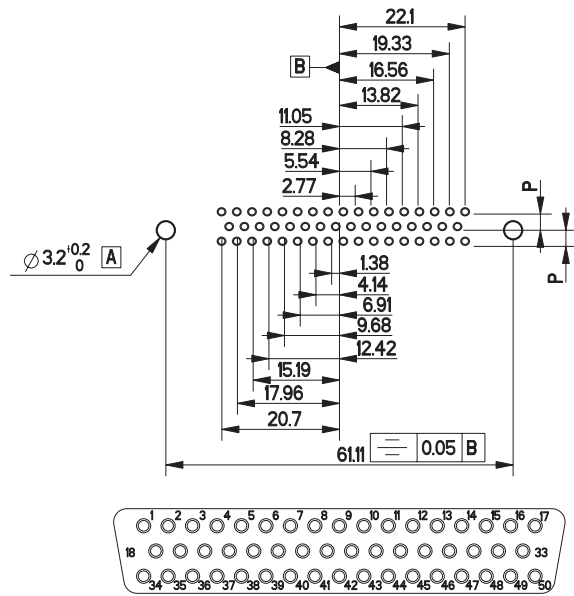

50 Contacts

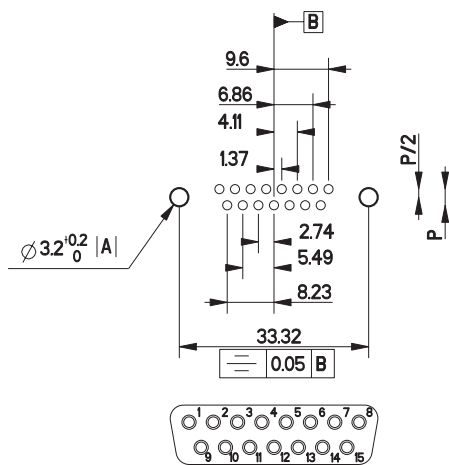

15 Contacts

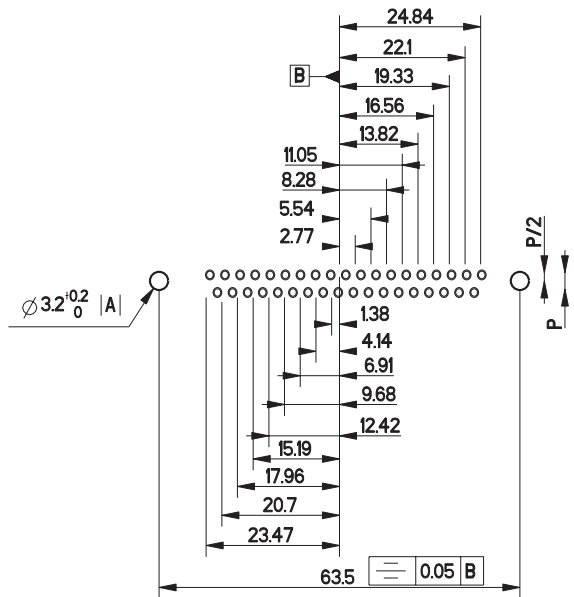

37 Contacts

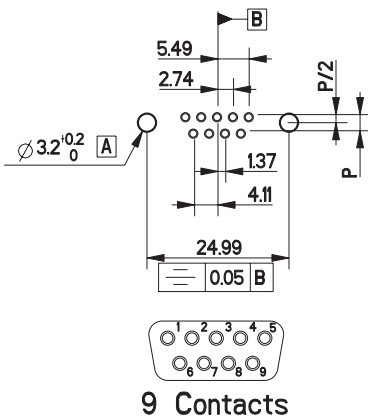

9 Contacts

NOTA: Drilling holes $1+0.1\varnothing$

Termination style	P
	0.05 A
Straight	284
90	254