

**CONNECTOR
DESIGNATORS
A-F-H-L-S
ROTATABLE
COUPLING**

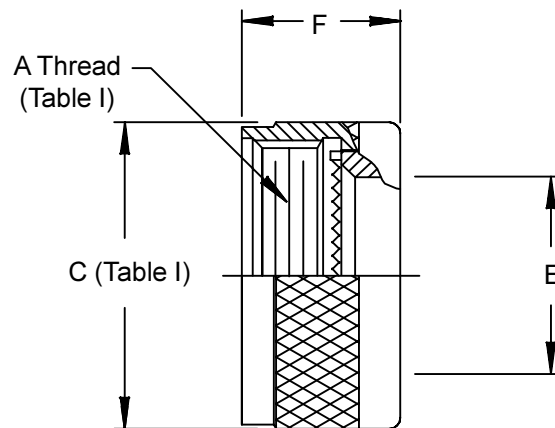
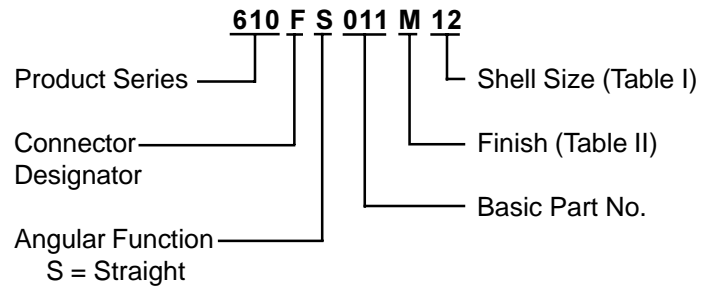

See inside back cover fold-out or pages 13 and 14 for Tables I and II.

TABLE III				
Shell Size		E Dia		F
Conn. Desig.	H	Ref		Max
A-F-L-S				
08	09	.270 (6.9)		.710 (18.0)
10	11	.375 (9.5)		.710 (18.0)
12	13	.511 (13.0)		.710 (18.0)
14	15	.585 (14.9)		.710 (18.0)
16	17	.710 (18.0)		.710 (18.0)
18	19	.789 (20.0)		.710 (18.0)
20	21	.914 (23.2)		.710 (18.0)
22	23	1.039 (26.4)		.710 (18.0)
24	25	1.154 (29.3)		.710 (18.0)
28		1.389 (35.3)		.890 (22.6)
32		1.635 (41.5)		.890 (22.6)
36		1.850 (47.0)		.890 (22.6)

Metric dimensions (mm) are indicated in parentheses.

**CONNECTOR
DESIGNATORS**
A-B*-C-D-E-F
G-H-J-K-L-S

* Conn. Desig. B See Note 2
DIRECT COUPLING

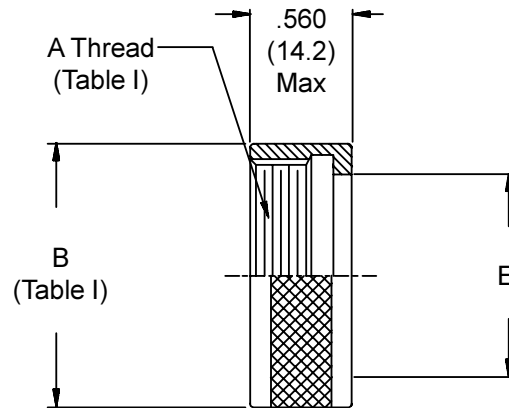
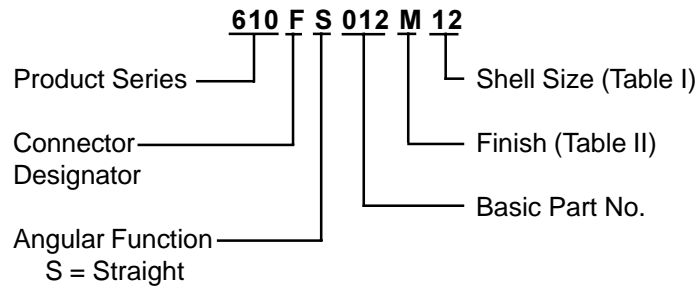

See inside back cover fold-out or pages 13 and 14 for Tables I and II.

Shell Size	E Dia Min
08/09	.250 (6.4)
10/11	.303 (7.7)
12/13	.408 (10.4)
14/15	.490 (12.4)
16/17	.609 (15.5)
18/19	.730 (18.5)
20/21	.870 (22.1)
22/23	.978 (24.8)
24/25	1.090 (27.7)
28	1.250 (31.8)
32	1.520 (38.6)
36	1.756 (44.6)

1. Metric dimensions (mm) are indicated in parentheses.
2. When using Connector Designator B refer to pages 18 and 19 for part number development.