

**CONNECTOR DESIGNATORS  
A-F-H-L-S  
ROTATABLE COUPLING**

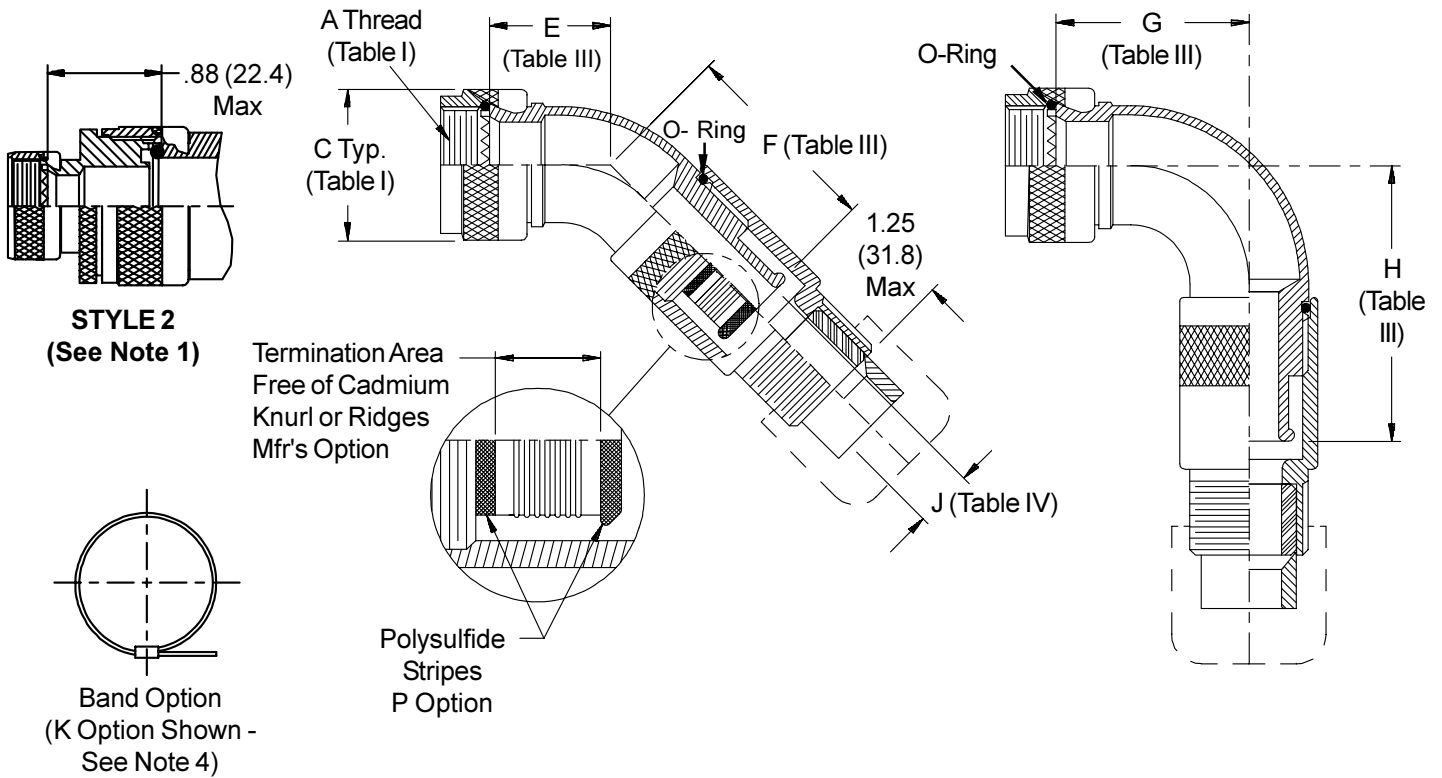

**STYLE H**  
Heavy Duty (Table X)

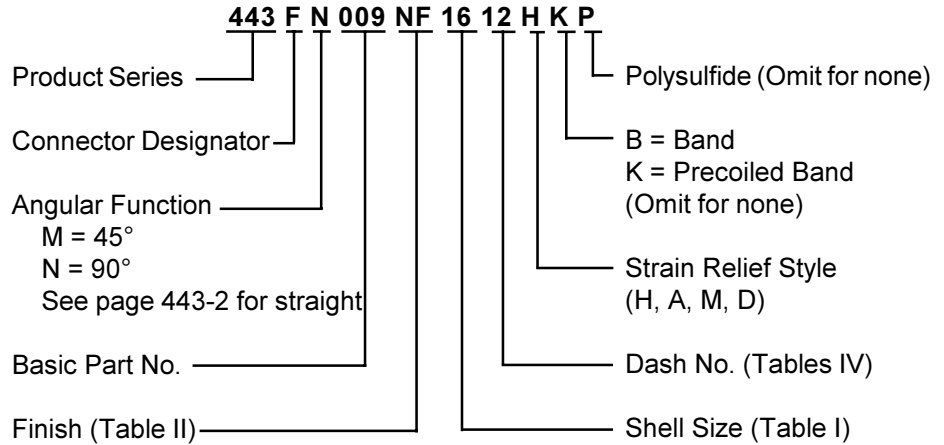
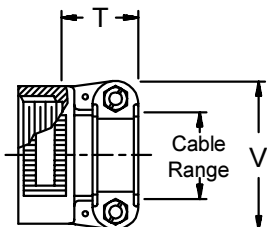

**STYLE A**  
Medium Duty (Table XI)

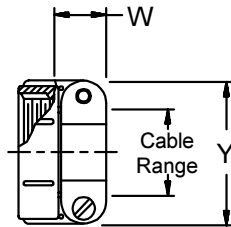

**STYLE M**  
Medium Duty (Table XI)

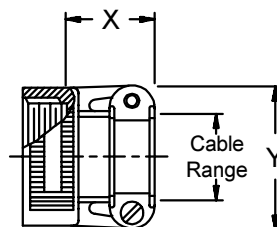

**STYLE D**  
Medium Duty (Table XI)

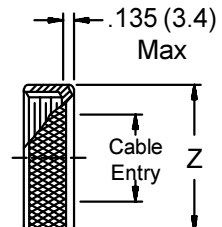

# Series 443 - Cable Sealing Band-in-a-Can Backshells



See inside back cover fold-out or pages 13 and 14 for Tables I and II.

**TABLE III**

Shell Size Conn. Desig. A-F-L-S H		E Max	F Max	G Max	H Max
08	09	.817 (20.8)	1.057 (26.8)	1.125 (28.6)	1.375 (34.9)
10	11	.861 (21.9)	1.111 (28.2)	1.250 (31.8)	1.500 (38.1)
12	13	.911 (23.1)	1.161 (29.5)	1.375 (34.9)	1.625 (41.3)
14	15	.965 (24.5)	1.215 (30.9)	1.500 (38.1)	1.750 (44.5)
16	17	1.014 (25.8)	1.264 (32.1)	1.625 (41.3)	1.875 (47.6)
18	19	1.064 (27.0)	1.314 (33.4)	1.750 (44.5)	2.000 (50.8)
20	21	1.118 (28.4)	1.368 (34.7)	1.875 (47.6)	2.125 (54.0)
22	23	1.172 (29.8)	1.422 (36.1)	2.000 (50.8)	2.250 (57.2)
24	25	1.221 (31.0)	1.471 (37.4)	2.125 (54.0)	2.375 (60.3)

**TABLE IV**

Dash No.	Clamp Size	J Dia
02	03	.125 (3.2)
03	03	.188 (4.8)
04	03	.250 (6.4)
05	04	.312 (7.9)
06	06	.375 (9.5)
07	06	.438 (11.1)
08	08	.500 (12.7)
09	10	.562 (14.3)
10	10	.625 (15.9)
11	12	.688 (17.5)
12	12	.750 (19.1)
13	16	.812 (20.6)
14	16	.875 (22.2)
15	16	.938 (23.8)
16	20	1.000 (25.4)
17	20	1.062 (27.0)
18	20	1.125 (28.6)
20	20	1.250 (31.8)
22	24	1.375 (34.9)
24	28	1.500 (38.1)

**TABLE X**

Clamp Size	T Max	V Max	Cable Range	
			Min	Max
04	.780 (19.8)	.957 (24.3)	.125 (3.2)	.312 (7.9)
06	.780 (19.8)	1.145 (29.1)	.250 (6.4)	.437 (11.1)
08	.780 (19.8)	1.332 (33.8)	.387 (9.8)	.562 (14.3)
10	.780 (19.8)	1.332 (33.8)	.350 (8.9)	.625 (15.9)
12	.811 (20.6)	1.551 (39.4)	.500 (12.7)	.750 (19.1)
16	.905 (23.0)	1.770 (45.0)	.625 (15.9)	.937 (23.8)
20	1.092 (27.7)	2.113 (53.7)	.875 (22.2)	1.250 (31.8)
24	1.124 (28.5)	2.363 (60.0)	1.000 (25.4)	1.375 (34.9)
28	1.399 (35.5)	2.770 (70.4)	1.250 (31.8)	1.625 (41.3)

**TABLE XI**

Clamp Size	W Max	X Max	Y Max	Z Max	Cable Range	
					Min **	Max
03*	.437 (11.1)	.760 (19.3)	.843 (21.4)	.630 (16.0)	.156 (4.0)	.250 (6.4)
04*	.437 (11.1)	.760 (19.3)	.906 (23.0)	.755 (19.2)	.188 (4.8)	.312 (7.9)
06*	.500 (12.7)	.760 (19.3)	1.093 (27.8)	.942 (23.9)	.281 (7.1)	.438 (11.1)
08	.563 (14.3)	.760 (19.3)	1.187 (30.1)	1.067 (27.1)	.387 (9.8)	.562 (14.3)
10	.563 (14.3)	.760 (19.3)	1.281 (32.5)	1.192 (30.3)	.375 (9.5)	.625 (15.9)
12	.563 (14.3)	.760 (19.3)	1.500 (38.1)	1.380 (35.1)	.438 (11.1)	.750 (19.1)
16	.656 (16.7)	1.073 (27.3)	1.719 (43.7)	1.535 (39.0)	.625 (15.9)	.938 (23.8)
20	.656 (16.7)	1.323 (33.6)	2.062 (52.4)	1.848 (46.9)	.875 (22.2)	1.250 (31.8)
24	.656 (16.7)	1.323 (33.6)	2.312 (58.7)	2.255 (57.3)	1.000 (25.4)	1.375 (34.9)
28	1.188 (30.2)	1.572 (39.9)	2.719 (69.1)	2.505 (63.6)	1.250 (31.8)	1.625 (41.3)

\* Not available in Style M clamp.      \*\* Not Applicable Style D

1. When maximum cable entry (page 21) is exceeded, Style 2 will be supplied. Dimensions E, F, G, and H will not apply. Please consult factory.
2. Metric dimensions (mm) are indicated in parentheses.
3. O-Ring not supplied with Connector Designator A.
4. Backshells supplied with 600-052-\* band, see Glenair Series 600 Tool Catalog for installation.

**CONNECTOR DESIGNATORS**  
**A-B\*-C-D-E-F**  
**G-H-J-K-L-S**

\* Conn. Desig. B See Note 3  
**DIRECT COUPLING**

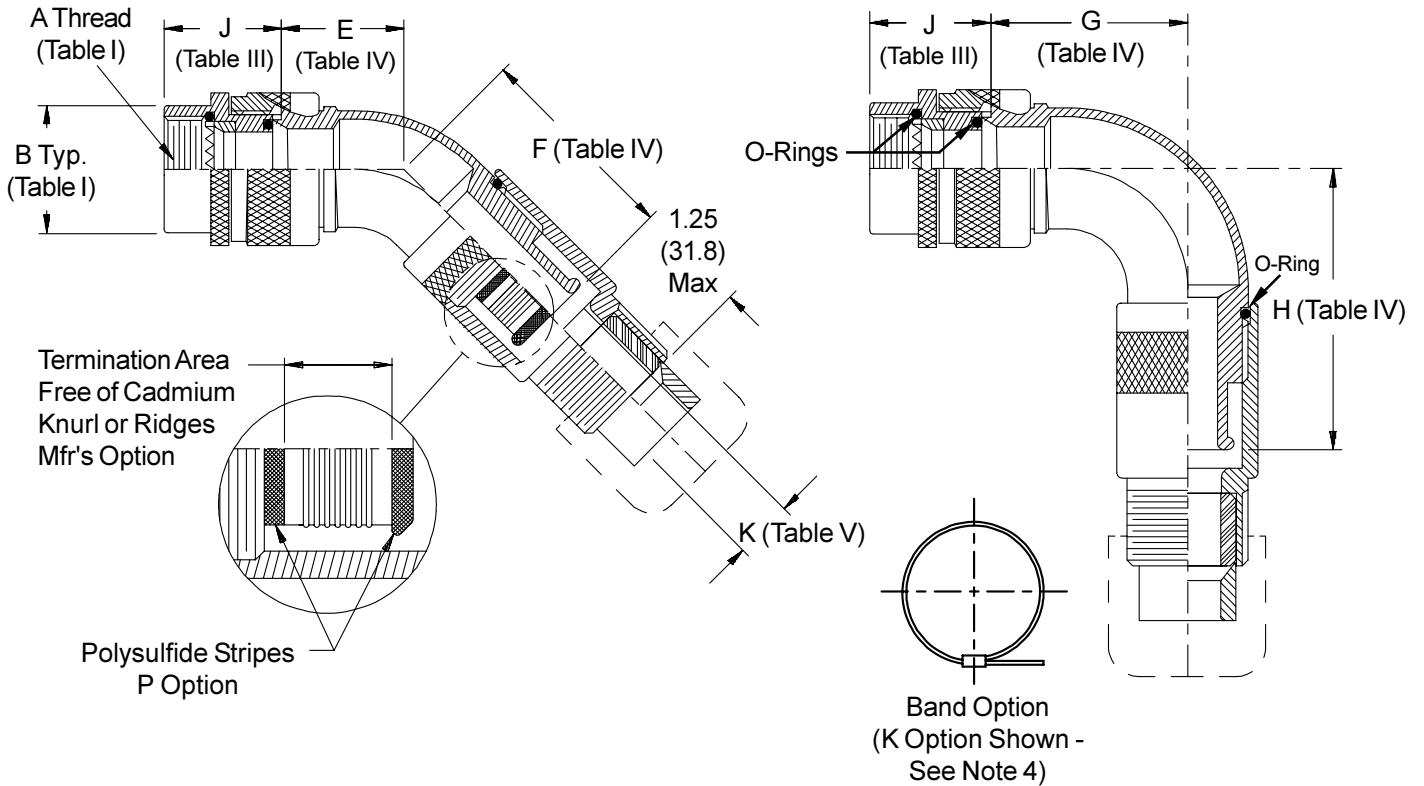
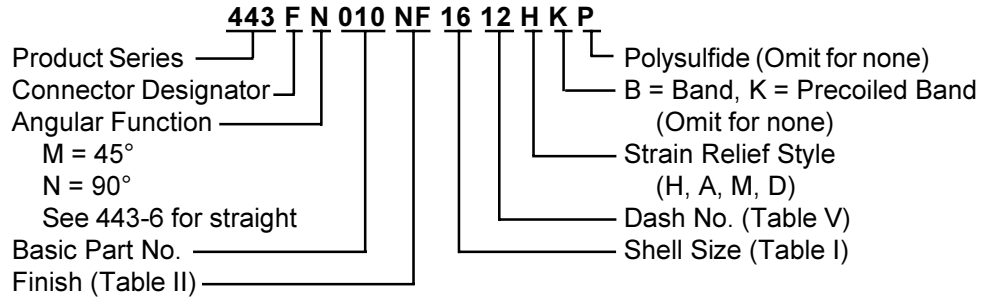

**STYLE H**  
 Heavy Duty (Table X)

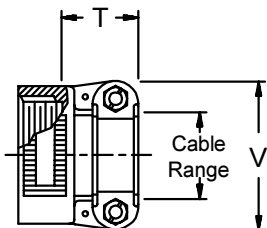

**STYLE A**  
 Medium Duty (Table XI)

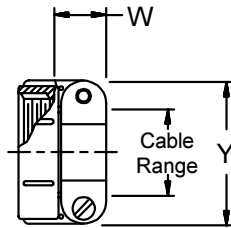

**STYLE M**  
 Medium Duty (Table XI)

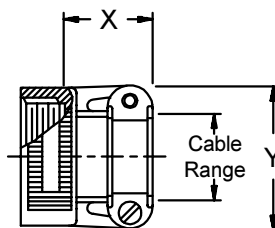

**STYLE D**  
 Medium Duty (Table XI)

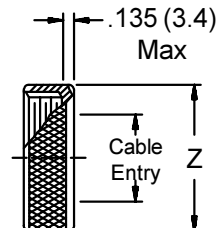

# Series 443 - Cable Sealing Band-in-a-Can Backshells



See inside back cover fold-out or pages 13 and 14 for Tables I and II.

Shell Size	J Max - Conn. Designator		
	A-D-E-F		C
	H-J-L-S	B-G-K	
08/09	1.000 (25.4)	1.000 (25.4)	
10/11	1.000 (25.4)	1.000 (25.4)	
12/13	1.000 (25.4)	1.000 (25.4)	1.735 (44.1)
14/15	1.000 (25.4)	1.000 (25.4)	1.915 (48.6)
16/17	1.000 (25.4)	1.166 (29.6)	1.915 (48.6)
18/19	1.000 (25.4)	1.166 (29.6)	1.915 (48.6)
20/21	1.000 (25.4)	1.166 (29.6)	1.915 (48.6)
22/23	1.000 (25.4)	1.166 (29.6)	1.915 (48.6)
24/25	1.000 (25.4)	1.166 (29.6)	1.915 (48.6)
28	1.000 (25.4)	1.166 (29.6)	1.915 (48.6)

Elbow Size	E Max	F Max	G Max	H Max
04	.875 (22.2)	1.100 (27.9)	1.250 (31.8)	1.505 (38.2)
06	.938 (23.8)	1.160 (29.5)	1.375 (34.9)	1.625 (41.3)
08	.938 (23.8)	1.160 (29.5)	1.375 (34.9)	1.625 (41.3)
10	1.062 (27.0)	1.290 (32.8)	1.625 (41.3)	1.875 (47.6)
12	1.094 (27.8)	1.350 (34.3)	1.750 (44.5)	1.995 (50.7)
16	1.156 (29.4)	1.410 (35.8)	1.875 (47.6)	2.125 (54.0)
20	1.570 (39.9)	1.820 (46.2)	2.765 (70.2)	2.500 (63.5)
24	1.570 (39.9)	1.820 (46.2)	2.765 (70.2)	2.500 (63.5)
28	1.820 (46.2)	2.070 (52.6)	3.225 (81.9)	2.620 (66.5)

Dash No.	Clamp Size	K Dia
05	04	.312 (7.9)
06	06	.375 (9.5)
07	06	.438 (11.1)
08	08	.500 (12.7)
09	10	.562 (14.3)
10	10	.625 (15.9)
11	12	.688 (17.5)
12	12	.750 (19.1)
13	16	.812 (20.6)
14	16	.875 (22.2)
15	16	.938 (23.8)
16	20	1.000 (25.4)
17	20	1.062 (27.0)
18	20	1.125 (28.6)
20	20	1.250 (31.8)
22	24	1.375 (34.9)
24	28	1.500 (38.1)

1. Metric dimensions (mm) are indicated in parentheses.
2. Cable range is defined as the accommodations range for the wire bundle or cable. Dimensions shown are not intended for inspection criteria.
3. When using Connector Designator B refer to pages 18 and 19 for part number development.
4. Backshells supplied with 600-052-\* band, see Glenair Series 600 Tool Catalog for installation.

Clamp Size	T Max	V Max	Cable Range			
			Min	Max		
04	.780 (19.8)	.957 (24.3)	.125 (3.2)	.312 (7.9)		
06	.780 (19.8)	1.145 (29.1)	.250 (6.4)	.437 (11.1)		
08	.780 (19.8)	1.332 (33.8)	.387 (9.8)	.562 (14.3)		
10	.780 (19.8)	1.332 (33.8)	.350 (8.9)	.625 (15.9)		
12	.811 (20.6)	1.551 (39.4)	.500 (12.7)	.750 (19.1)		
16	.905 (23.0)	1.770 (45.0)	.625 (15.9)	.937 (23.8)		
20	1.092 (27.7)	2.113 (53.7)	.875 (22.2)	1.250 (31.8)		
24	1.124 (28.5)	2.363 (60.0)	1.000 (25.4)	1.375 (34.9)		
28	1.399 (35.5)	2.770 (70.4)	1.250 (31.8)	1.625 (41.3)		

Clamp Size	W Max	X Max	Y Max	Z Max	Cable Range			
					Min **	Max		
03*	.437 (11.1)	.760 (19.3)	.843 (21.4)	.630 (16.0)	.156 (4.0)	.250 (6.4)		
04*	.437 (11.1)	.760 (19.3)	.906 (23.0)	.755 (19.2)	.188 (4.8)	.312 (7.9)		
06*	.500 (12.7)	.760 (19.3)	1.093 (27.8)	.942 (23.9)	.281 (7.1)	.438 (11.1)		
08	.563 (14.3)	.760 (19.3)	1.187 (30.1)	1.067 (27.1)	.387 (9.8)	.562 (14.3)		
10	.563 (14.3)	.760 (19.3)	1.281 (32.5)	1.192 (30.3)	.375 (9.5)	.625 (15.9)		
12	.563 (14.3)	.760 (19.3)	1.500 (38.1)	1.380 (35.1)	.438 (11.1)	.750 (19.1)		
16	.656 (16.7)	1.073 (27.3)	1.719 (43.7)	1.535 (39.0)	.625 (15.9)	.938 (23.8)		
20	.656 (16.7)	1.323 (33.6)	2.062 (52.4)	1.848 (46.9)	.875 (22.2)	1.250 (31.8)		
24	.656 (16.7)	1.323 (33.6)	2.312 (58.7)	2.255 (57.3)	1.000 (25.4)	1.375 (34.9)		
28	1.188 (30.2)	1.572 (39.9)	2.719 (69.1)	2.505 (63.6)	1.250 (31.8)	1.625 (41.3)		

\* Not available in Style M clamp.      \*\* Not Applicable Style D

**CONNECTOR  
DESIGNATORS  
A-F-H-L-S  
SELF-LOCKING  
ROTATABLE  
COUPLING**

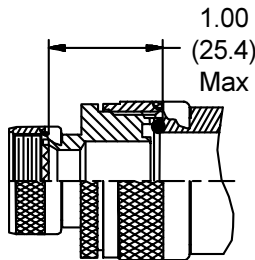
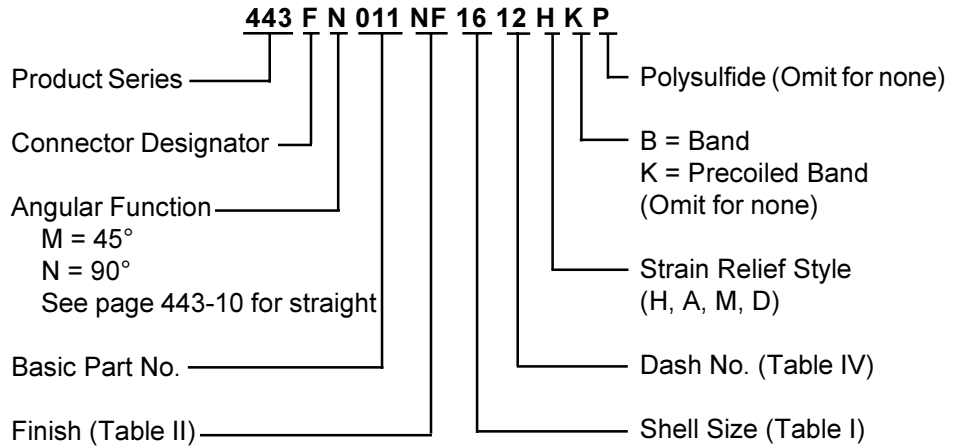

**STYLE 2**  
(See Note 1)

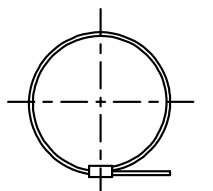

Band Option  
(K Option Shown -  
See Note 4)

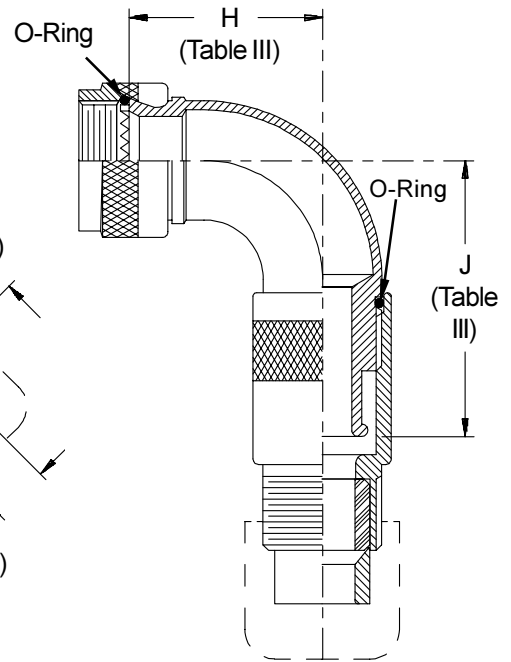
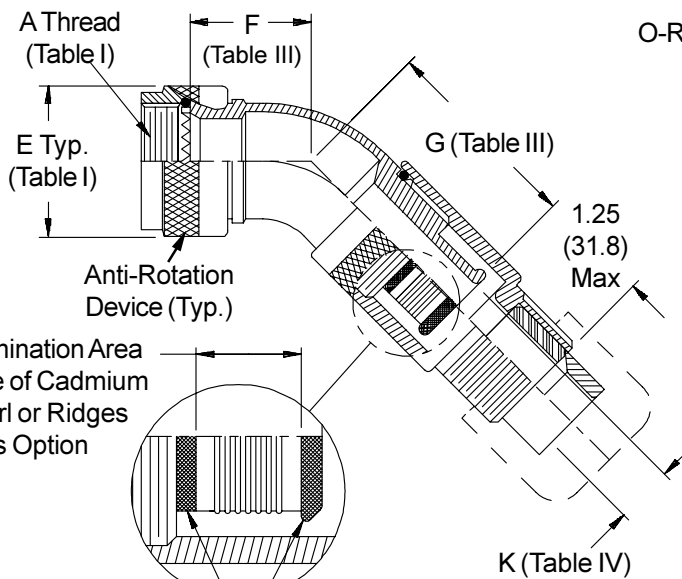

**STYLE H**  
Heavy Duty (Table X)

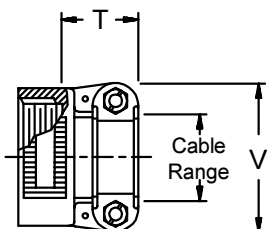

**STYLE A**  
Medium Duty (Table XI)

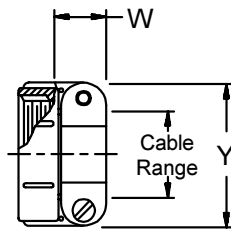

**STYLE M**  
Medium Duty (Table XI)

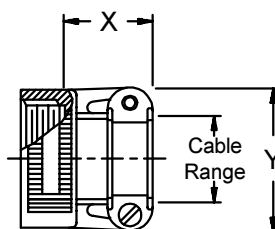

**STYLE D**  
Medium Duty (Table XI)

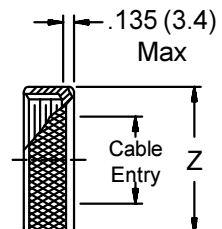

# Series 443 - Cable Sealing Band-in-a-Can Backshells



See inside back cover fold-out or pages 13 and 14 for Tables I and II.

**TABLE III**

Shell Size Conn. Desig. A-F-L-S H		F Max	G Max	H Max	J Max
08	09	.968 (24.6)	1.057 (26.8)	1.281 (32.5)	1.375 (34.9)
10	11	1.031 (26.2)	1.111 (28.2)	1.406 (35.7)	1.500 (38.1)
12	13	1.094 (27.8)	1.161 (29.5)	1.531 (38.9)	1.625 (41.3)
14	15	1.156 (29.4)	1.215 (30.9)	1.656 (42.1)	1.750 (44.5)
16	17	1.219 (31.0)	1.264 (32.1)	1.781 (45.2)	1.875 (47.6)
18	19	1.250 (31.8)	1.314 (33.4)	1.906 (48.4)	2.000 (50.8)
20	21	1.312 (33.3)	1.368 (34.7)	2.031 (51.6)	2.125 (54.0)
22	23	1.344 (34.1)	1.422 (36.1)	2.156 (54.8)	2.250 (57.2)
24	25	1.406 (35.7)	1.471 (37.4)	2.281 (57.9)	2.375 (60.3)

**TABLE IV**

Dash No.	Clamp Size	K Dia
02	03	.125 (3.2)
03	03	.188 (4.8)
04	03	.250 (6.4)
05	04	.312 (7.9)
06	06	.375 (9.5)
07	06	.438 (11.1)
08	08	.500 (12.7)
09	10	.562 (14.3)
10	10	.625 (15.9)
11	12	.688 (17.5)
12	12	.750 (19.1)
13	16	.812 (20.6)
14	16	.875 (22.2)
15	16	.938 (23.8)
16	20	1.000 (25.4)
17	20	1.062 (27.0)
18	20	1.125 (28.6)
20	20	1.250 (31.8)
22	24	1.375 (34.9)
24	28	1.500 (38.1)

**TABLE X**

Clamp Size	T Max	V Max	Cable Range	
			Min	Max
04	.780 (19.8)	.957 (24.3)	.125 (3.2)	.312 (7.9)
06	.780 (19.8)	1.145 (29.1)	.250 (6.4)	.437 (11.1)
08	.780 (19.8)	1.332 (33.8)	.387 (9.8)	.562 (14.3)
10	.780 (19.8)	1.332 (33.8)	.350 (8.9)	.625 (15.9)
12	.811 (20.6)	1.551 (39.4)	.500 (12.7)	.750 (19.1)
16	.905 (23.0)	1.770 (45.0)	.625 (15.9)	.937 (23.8)
20	1.092 (27.7)	2.113 (53.7)	.875 (22.2)	1.250 (31.8)
24	1.124 (28.5)	2.363 (60.0)	1.000 (25.4)	1.375 (34.9)
28	1.399 (35.5)	2.770 (70.4)	1.250 (31.8)	1.625 (41.3)

**TABLE XI**

Clamp Size	W Max	X Max	Y Max	Z Max	Cable Range	
					Min **	Max
03*	.437 (11.1)	.760 (19.3)	.843 (21.4)	.630 (16.0)	.156 (4.0)	.250 (6.4)
04*	.437 (11.1)	.760 (19.3)	.906 (23.0)	.755 (19.2)	.188 (4.8)	.312 (7.9)
06*	.500 (12.7)	.760 (19.3)	1.093 (27.8)	.942 (23.9)	.281 (7.1)	.438 (11.1)
08	.563 (14.3)	.760 (19.3)	1.187 (30.1)	1.067 (27.1)	.387 (9.8)	.562 (14.3)
10	.563 (14.3)	.760 (19.3)	1.281 (32.5)	1.192 (30.3)	.375 (9.5)	.625 (15.9)
12	.563 (14.3)	.760 (19.3)	1.500 (38.1)	1.380 (35.1)	.438 (11.1)	.750 (19.1)
16	.656 (16.7)	1.073 (27.3)	1.719 (43.7)	1.535 (39.0)	.625 (15.9)	.938 (23.8)
20	.656 (16.7)	1.323 (33.6)	2.062 (52.4)	1.848 (46.9)	.875 (22.2)	1.250 (31.8)
24	.656 (16.7)	1.323 (33.6)	2.312 (58.7)	2.255 (57.3)	1.000 (25.4)	1.375 (34.9)
28	1.188 (30.2)	1.572 (39.9)	2.719 (69.1)	2.505 (63.6)	1.250 (31.8)	1.625 (41.3)

\* Not available in Style M clamp.      \*\* Not Applicable Style D

1. When maximum cable entry (page 21) is exceeded, Style 2 will be supplied. Dimensions F, G, H and J will not apply. Please consult factory.
2. Metric dimensions (mm) are indicated in parentheses.
3. O-Ring not supplied with Connector Designator A.
4. Backshells supplied with 600-052-\* band, see Glenair Series 600 Tool Catalog for installation.

**CONNECTOR  
DESIGNATORS  
A-F-H-L-S  
ROTATABLE  
COUPLING**

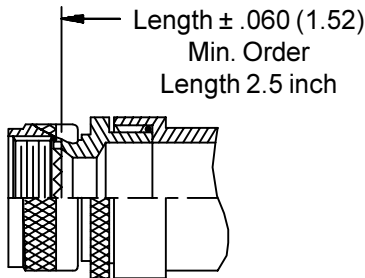
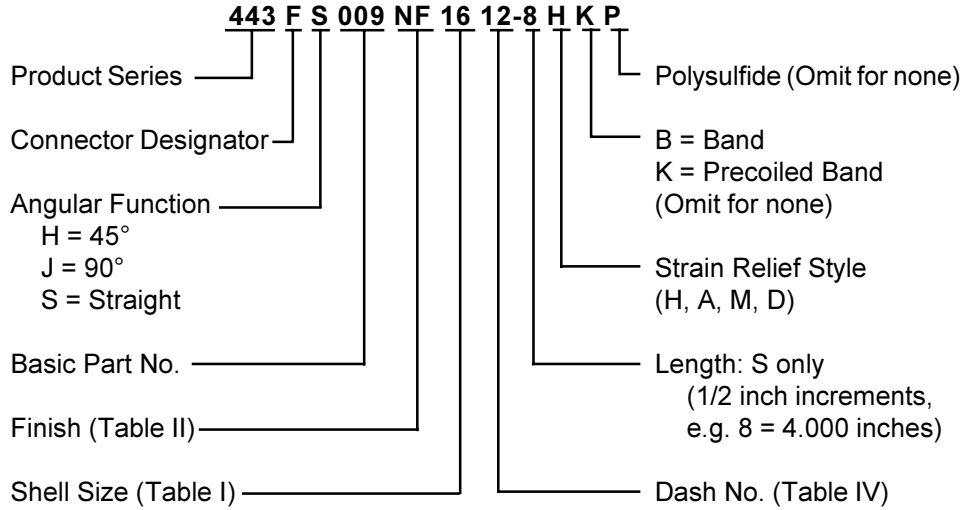

**STYLE 2  
(STRAIGHT  
See Note 1)**

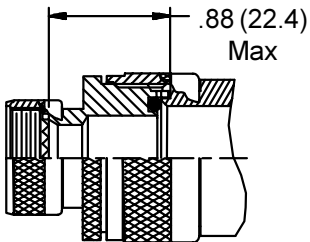

**STYLE 2  
(45° & 90°  
See Note 1)**

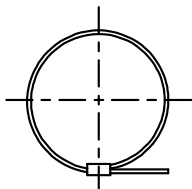

Termination Area  
Free of Cadmium  
Knurl or Ridges  
Mfr's Option

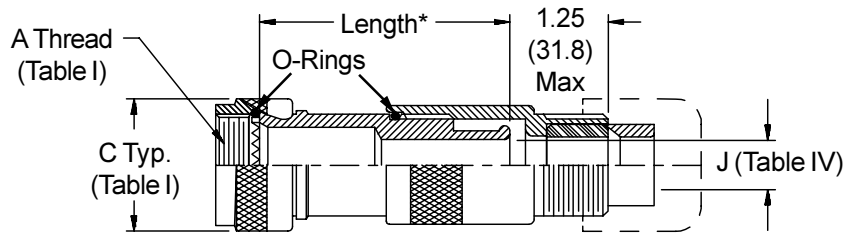
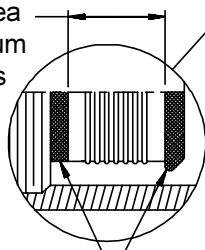

\* Length ± .060 (1.52)  
Min. Order Length 2.0 inch  
(Consult factory for shorter lengths)

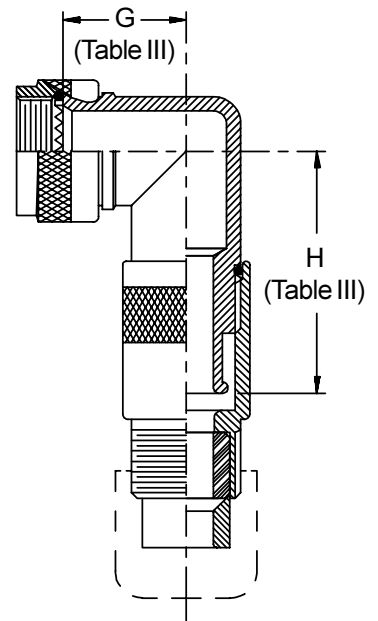
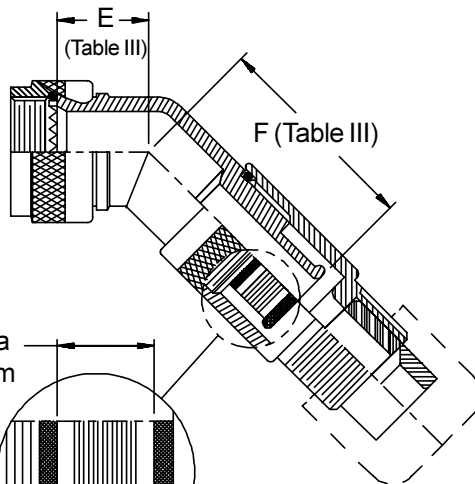

# Series 443 - Cable Sealing Band-in-a-Can Backshells



See inside back cover fold-out or pages 13 and 14 for Tables I and II.

TABLE III

Shell Size		E		F		G		H	
Conn. Desig.	H	Max		Max		Max		Max	
A-F-L-S									
08	09	.639	(16.2)	1.380	(35.1)	.750	(19.1)	1.500	(38.1)
10	11	.664	(16.9)	1.410	(35.8)	.810	(20.6)	1.550	(39.4)
12	13	.688	(17.5)	1.430	(36.3)	.870	(22.1)	1.610	(40.9)
14	15	.705	(17.9)	1.460	(37.1)	.920	(23.4)	1.680	(42.7)
16	17	.732	(18.6)	1.480	(37.6)	.980	(24.9)	1.740	(44.2)
18	19	.748	(19.0)	1.490	(37.8)	1.020	(25.9)	1.760	(44.7)
20	21	.773	(19.6)	1.510	(38.4)	1.080	(27.4)	1.820	(46.2)
22	23	.800	(20.3)	1.550	(39.4)	1.140	(29.0)	1.900	(48.3)
24	25	.823	(20.9)	1.580	(40.1)	1.200	(30.5)	1.970	(50.0)

TABLE IV

Dash No.	Clamp Size	J Dia	
02	03	.125	(3.2)
03	03	.188	(4.8)
04	03	.250	(6.4)
05	04	.312	(7.9)
06	06	.375	(9.5)
07	06	.438	(11.1)
08	08	.500	(12.7)
09	10	.562	(14.3)
10	10	.625	(15.9)
11	12	.688	(17.5)
12	12	.750	(19.1)
13	16	.812	(20.6)
14	16	.875	(22.2)
15	16	.938	(23.8)
16	20	1.000	(25.4)
17	20	1.062	(27.0)
18	20	1.125	(28.6)
20	20	1.250	(31.8)
22	24	1.375	(34.9)
24	28	1.500	(38.1)

TABLE X

Clamp Size	T Max	V Max	Cable Range			
			Min		Max	
04	.780 (19.8)	.957 (24.3)	.125 (3.2)	.312 (7.9)		
06	.780 (19.8)	1.145 (29.1)	.250 (6.4)	.437 (11.1)		
08	.780 (19.8)	1.332 (33.8)	.387 (9.8)	.562 (14.3)		
10	.780 (19.8)	1.332 (33.8)	.350 (8.9)	.625 (15.9)		
12	.811 (20.6)	1.551 (39.4)	.500 (12.7)	.750 (19.1)		
16	.905 (23.0)	1.770 (45.0)	.625 (15.9)	.937 (23.8)		
20	1.092 (27.7)	2.113 (53.7)	.875 (22.2)	1.250 (31.8)		
24	1.124 (28.5)	2.363 (60.0)	1.000 (25.4)	1.375 (34.9)		
28	1.399 (35.5)	2.770 (70.4)	1.250 (31.8)	1.625 (41.3)		

TABLE XI

Clamp Size	W Max	X Max	Y Max	Z Max	Cable Range		
					Min **		Max
03*	.437 (11.1)	.760 (19.3)	.843 (21.4)	.630 (16.0)	.156 (4.0)	.250 (6.4)	
04*	.437 (11.1)	.760 (19.3)	.906 (23.0)	.755 (19.2)	.188 (4.8)	.312 (7.9)	
06*	.500 (12.7)	.760 (19.3)	1.093 (27.8)	.942 (23.9)	.281 (7.1)	.438 (11.1)	
08	.563 (14.3)	.760 (19.3)	1.187 (30.1)	1.067 (27.1)	.387 (9.8)	.562 (14.3)	
10	.563 (14.3)	.760 (19.3)	1.281 (32.5)	1.192 (30.3)	.375 (9.5)	.625 (15.9)	
12	.563 (14.3)	.760 (19.3)	1.500 (38.1)	1.380 (35.1)	.438 (11.1)	.750 (19.1)	
16	.656 (16.7)	1.073 (27.3)	1.719 (43.7)	1.535 (39.0)	.625 (15.9)	.938 (23.8)	
20	.656 (16.7)	1.323 (33.6)	2.062 (52.4)	1.848 (46.9)	.875 (22.2)	1.250 (31.8)	
24	.656 (16.7)	1.323 (33.6)	2.312 (58.7)	2.255 (57.3)	1.000 (25.4)	1.375 (34.9)	
28	1.188 (30.2)	1.572 (39.9)	2.719 (69.1)	2.505 (63.6)	1.250 (31.8)	1.625 (41.3)	

\* Not available in Style M clamp.      \*\* Not Applicable Style D

1. When maximum cable entry (page 21) is exceeded, Style 2 will be supplied. Dimensions E, F, G, and H will not apply. Please consult factory.
2. Metric dimensions (mm) are indicated in parentheses.
3. O-Ring not supplied with Connector Designator A.
4. Backshells supplied with 600-052-\* band, see Glenair Series 600 Tool Catalog for installation.

STYLE H  
Heavy Duty (Table X)

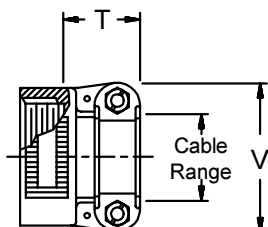

STYLE A  
Medium Duty (Table XI)

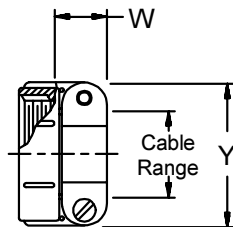

STYLE M  
Medium Duty (Table XI)

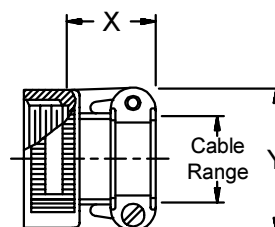

STYLE D  
Medium Duty (Table XI)

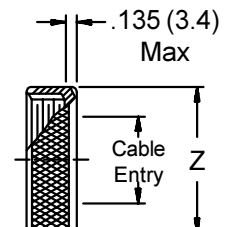

## CONNECTOR DESIGNATORS

**A-B\*-C-D-E-F**  
**G-H-J-K-L-S**

\* Conn. Desig. B See Note 5

## DIRECT COUPLING

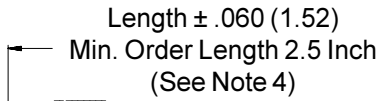
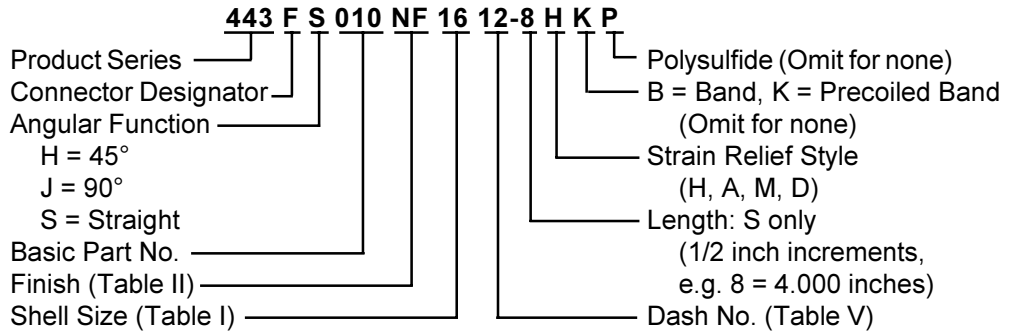

**STYLE 2 (STRAIGHT)**  
See Note 1)

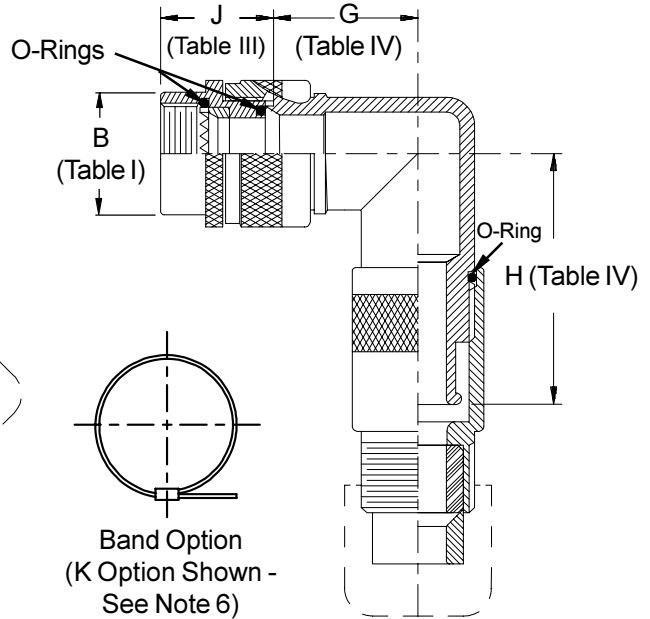
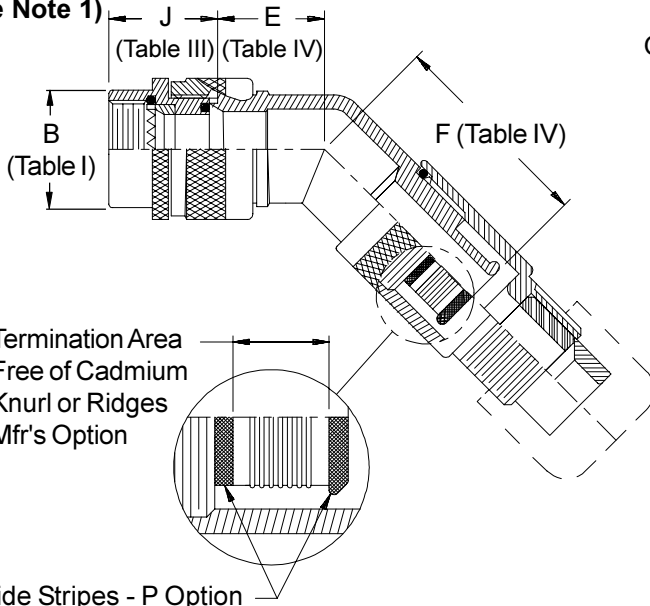
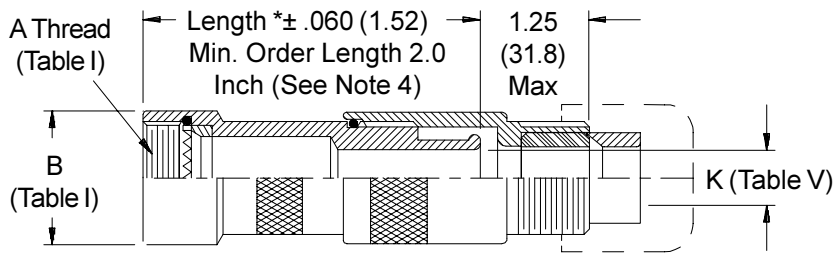

**STYLE H**  
Heavy Duty (Table X)

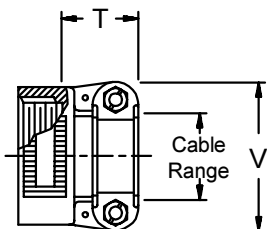

**STYLE A**  
Medium Duty (Table XI)

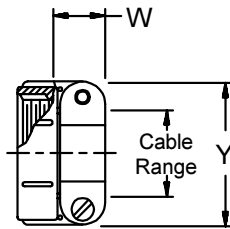

**STYLE M**  
Medium Duty (Table XI)

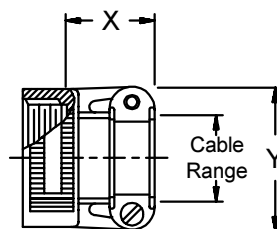

**STYLE D**  
Medium Duty (Table XI)

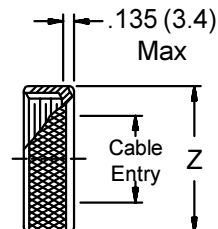

# Series 443 - Cable Sealing Band-in-a-Can Backshells



**TABLE III**

Shell Size	J Max - Conn. Designator		
	A-D-E-F		C
	H-J-L-S	B-G-K	
08/09	1.000 (25.4)	1.000 (25.4)	
10/11	1.000 (25.4)	1.000 (25.4)	
12/13	1.000 (25.4)	1.000 (25.4)	1.735 (44.1)
14/15	1.000 (25.4)	1.000 (25.4)	1.915 (48.6)
16/17	1.000 (25.4)	1.166 (29.6)	1.915 (48.6)
18/19	1.000 (25.4)	1.166 (29.6)	1.915 (48.6)
20/21	1.000 (25.4)	1.166 (29.6)	1.915 (48.6)
22/23	1.000 (25.4)	1.166 (29.6)	1.915 (48.6)
24/25	1.000 (25.4)	1.166 (29.6)	1.915 (48.6)
28	1.000 (25.4)	1.166 (29.6)	1.915 (48.6)

**TABLE IV**

Elbow Size	E Max	F Max	G Max	H Max
04	.664 (16.9)	1.410 (35.8)	.810 (20.6)	1.550 (39.4)
06	.688 (17.5)	1.430 (36.3)	.870 (22.1)	1.610 (40.9)
08	.688 (17.5)	1.430 (36.3)	.870 (22.1)	1.610 (40.9)
10	.732 (18.6)	1.480 (37.6)	.980 (24.9)	1.740 (44.2)
12	.748 (19.0)	1.490 (37.8)	1.020 (25.9)	1.760 (44.7)
16	.773 (19.6)	1.510 (38.4)	1.080 (27.4)	1.820 (46.2)
20	1.041 (26.4)	1.750 (44.5)	1.480 (37.6)	2.210 (56.1)
24	1.041 (26.4)	1.750 (44.5)	1.480 (37.6)	2.210 (56.1)
28	1.092 (27.7)	1.790 (45.5)	1.610 (40.9)	2.300 (58.4)

**TABLE V**

Dash No.	Clamp Size	K Dia
02	03	.125 (3.2)
03	03	.188 (4.8)
04	03	.250 (6.4)
05	04	.312 (7.9)
06	06	.375 (9.5)
07	06	.438 (11.1)
08	08	.500 (12.7)
09	10	.562 (14.3)
10	10	.625 (15.9)
11	12	.688 (17.5)
12	12	.750 (19.1)
13	16	.812 (20.6)
14	16	.875 (22.2)
15	16	.938 (23.8)
16	20	1.000 (25.4)
17	20	1.062 (27.0)
18	20	1.125 (28.6)
20	20	1.250 (31.8)
22	24	1.375 (34.9)
24	28	1.500 (38.1)

See inside back cover fold-out or pages 13 and 14 for Tables I and II.

1. When maximum cable entry (page 22) is exceeded, Style 2 will be supplied. (Function S only).
2. Metric dimensions (mm) are indicated in parentheses.
3. Cable range is defined as the accommodations range for the wire bundle or cable. Dimensions shown are not intended for inspection criteria.
4. Consult factory for shorter lengths on straight backshells.
5. When using Connector Designator B refer to pages 18 and 19 for part number development.
6. Backshells supplied with 600-052-\* band, see Glenair Series 600 Tool Catalog for installation.

**TABLE X**

Clamp Size	T Max	V Max	Cable Range			
			Min		Max	
			04	.780 (19.8)	.957 (24.3)	.125 (3.2)
06	.780 (19.8)	1.145 (29.1)	.250 (6.4)	.437 (11.1)		
08	.780 (19.8)	1.332 (33.8)	.387 (9.8)	.562 (14.3)		
10	.780 (19.8)	1.332 (33.8)	.350 (8.9)	.625 (15.9)		
12	.811 (20.6)	1.551 (39.4)	.500 (12.7)	.750 (19.1)		
16	.905 (23.0)	1.770 (45.0)	.625 (15.9)	.937 (23.8)		
20	1.092 (27.7)	2.113 (53.7)	.875 (22.2)	1.250 (31.8)		
24	1.124 (28.5)	2.363 (60.0)	1.000 (25.4)	1.375 (34.9)		
28	1.399 (35.5)	2.770 (70.4)	1.250 (31.8)	1.625 (41.3)		

**TABLE XI**

Clamp Size	W Max	X Max	Y Max	Z Max	Cable Range	
					Min **	Max
					03*	.437 (11.1)
04*	.437 (11.1)	.760 (19.3)	.906 (23.0)	.755 (19.2)	.188 (4.8)	.312 (7.9)
06*	.500 (12.7)	.760 (19.3)	1.093 (27.8)	.942 (23.9)	.281 (7.1)	.438 (11.1)
08	.563 (14.3)	.760 (19.3)	1.187 (30.1)	1.067 (27.1)	.387 (9.8)	.562 (14.3)
10	.563 (14.3)	.760 (19.3)	1.281 (32.5)	1.192 (30.3)	.375 (9.5)	.625 (15.9)
12	.563 (14.3)	.760 (19.3)	1.500 (38.1)	1.380 (35.1)	.438 (11.1)	.750 (19.1)
16	.656 (16.7)	1.073 (27.3)	1.719 (43.7)	1.535 (39.0)	.625 (15.9)	.938 (23.8)
20	.656 (16.7)	1.323 (33.6)	2.062 (52.4)	1.848 (46.9)	.875 (22.2)	1.250 (31.8)
24	.656 (16.7)	1.323 (33.6)	2.312 (58.7)	2.255 (57.3)	1.000 (25.4)	1.375 (34.9)
28	1.188 (30.2)	1.572 (39.9)	2.719 (69.1)	2.505 (63.6)	1.250 (31.8)	1.625 (41.3)

\* Not available in Style M clamp.

\*\* Not Applicable Style D

**Series 443 - Cable Sealing Band-in-a-Can Backshells**

**CONNECTOR DESIGNATORS**  
**A-F-H-L-S**  
**SELF-LOCKING ROTATABLE COUPLING**

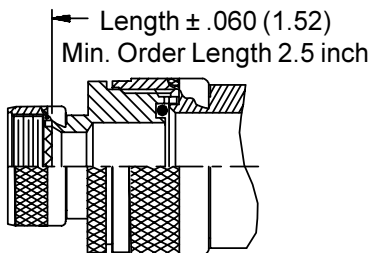
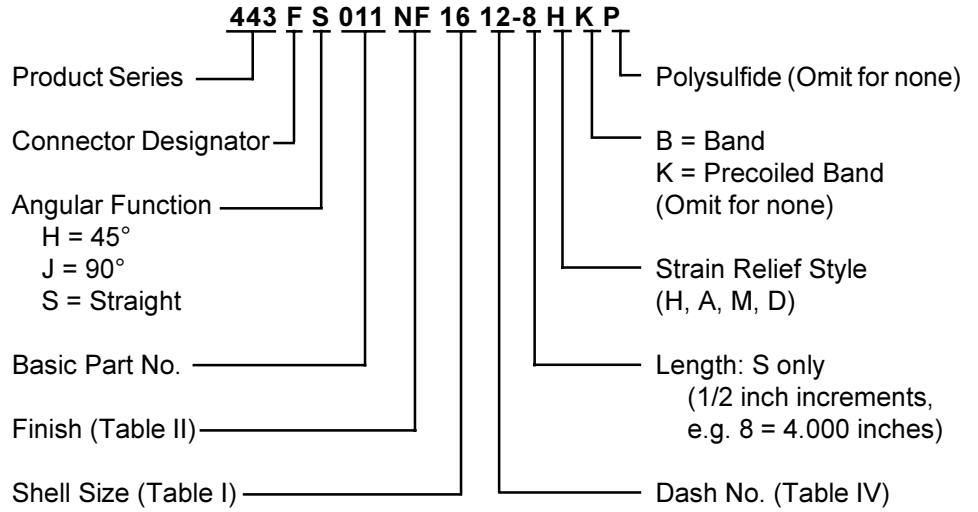

**STYLE 2 (STRAIGHT)**  
 See Note 1)

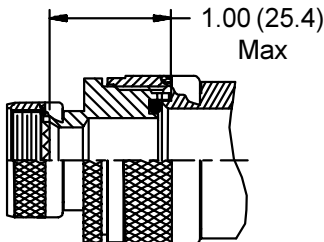
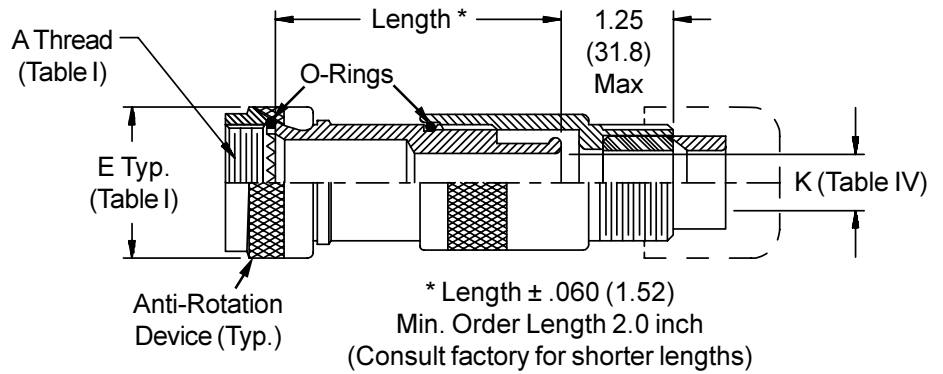

**STYLE 2 (45° & 90°)**  
 See Note 1)

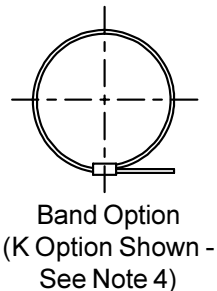
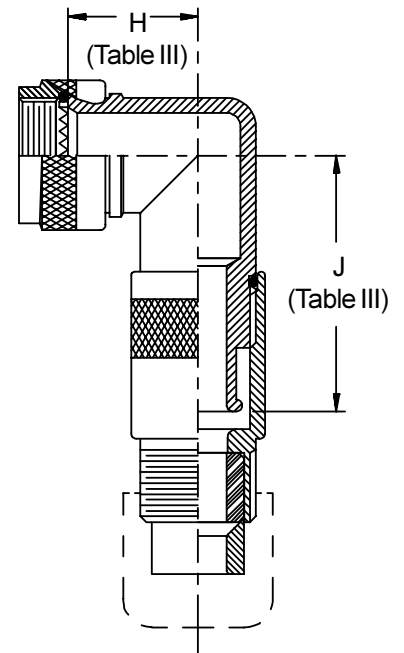
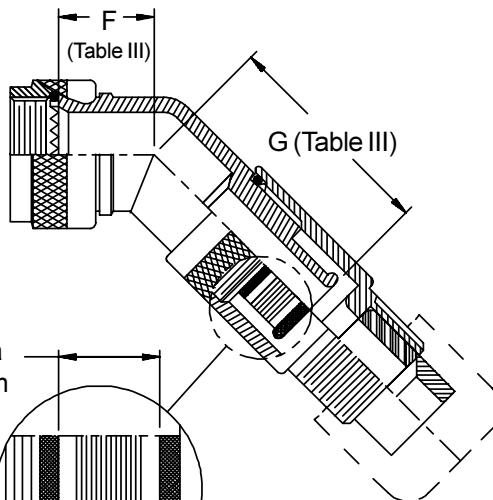

Termination Area Free of Cadmium  
 Knurl or Ridges  
 Mfr's Option

Polysulfide Stripes  
 P Option

# Series 443 - Cable Sealing Band-in-a-Can Backshells



See inside back cover fold-out or pages 13 and 14 for Tables I and II.

TABLE III

Shell Size Conn. Desig. A-F-L-S	H	F Max	G Max	H Max	J Max
08	09	.795 (20.2)	1.380 (35.1)	.906 (23.0)	1.500 (38.1)
10	11	.820 (20.8)	1.410 (35.8)	.966 (24.5)	1.550 (39.4)
12	13	.844 (21.4)	1.430 (36.3)	1.026 (26.1)	1.610 (40.9)
14	15	.861 (21.9)	1.460 (37.1)	1.076 (27.3)	1.680 (42.7)
16	17	.888 (22.6)	1.480 (37.6)	1.136 (28.9)	1.740 (44.2)
18	19	.904 (23.0)	1.490 (37.8)	1.176 (29.9)	1.760 (44.7)
20	21	.929 (23.6)	1.510 (38.4)	1.236 (31.4)	1.820 (46.2)
22	23	.956 (24.3)	1.550 (39.4)	1.296 (32.9)	1.900 (48.3)
24	25	.979 (24.9)	1.580 (40.1)	1.356 (34.4)	1.970 (50.0)

TABLE IV

Dash No.	Clamp Size	K Dia
02	03	.125 (3.2)
03	03	.188 (4.8)
04	03	.250 (6.4)
05	04	.312 (7.9)
06	06	.375 (9.5)
07	06	.438 (11.1)
08	08	.500 (12.7)
09	10	.562 (14.3)
10	10	.625 (15.9)
11	12	.688 (17.5)
12	12	.750 (19.1)
13	16	.812 (20.6)
14	16	.875 (22.2)
15	16	.938 (23.8)
16	20	1.000 (25.4)
17	20	1.062 (27.0)
18	20	1.125 (28.6)
20	20	1.250 (31.8)
22	24	1.375 (34.9)
24	28	1.500 (38.1)

TABLE X

Clamp Size	T Max	V Max	Cable Range	
			Min	Max
04	.780 (19.8)	.957 (24.3)	.125 (3.2)	.312 (7.9)
06	.780 (19.8)	1.145 (29.1)	.250 (6.4)	.437 (11.1)
08	.780 (19.8)	1.332 (33.8)	.387 (9.8)	.562 (14.3)
10	.780 (19.8)	1.332 (33.8)	.350 (8.9)	.625 (15.9)
12	.811 (20.6)	1.551 (39.4)	.500 (12.7)	.750 (19.1)
16	.905 (23.0)	1.770 (45.0)	.625 (15.9)	.937 (23.8)
20	1.092 (27.7)	2.113 (53.7)	.875 (22.2)	1.250 (31.8)
24	1.124 (28.5)	2.363 (60.0)	1.000 (25.4)	1.375 (34.9)
28	1.399 (35.5)	2.770 (70.4)	1.250 (31.8)	1.625 (41.3)

TABLE XI

Clamp Size	W Max	X Max	Y Max	Z Max	Cable Range	
					Min**	Max
03*	.437 (11.1)	.760 (19.3)	.843 (21.4)	.630 (16.0)	.156 (4.0)	.250 (6.4)
04*	.437 (11.1)	.760 (19.3)	.906 (23.0)	.755 (19.2)	.188 (4.8)	.312 (7.9)
06*	.500 (12.7)	.760 (19.3)	1.093 (27.8)	.942 (23.9)	.281 (7.1)	.438 (11.1)
08	.563 (14.3)	.760 (19.3)	1.187 (30.1)	1.067 (27.1)	.387 (9.8)	.562 (14.3)
10	.563 (14.3)	.760 (19.3)	1.281 (32.5)	1.192 (30.3)	.375 (9.5)	.625 (15.9)
12	.563 (14.3)	.760 (19.3)	1.500 (38.1)	1.380 (35.1)	.438 (11.1)	.750 (19.1)
16	.656 (16.7)	1.073 (27.3)	1.719 (43.7)	1.535 (39.0)	.625 (15.9)	.938 (23.8)
20	.656 (16.7)	1.323 (33.6)	2.062 (52.4)	1.848 (46.9)	.875 (22.2)	1.250 (31.8)
24	.656 (16.7)	1.323 (33.6)	2.312 (58.7)	2.255 (57.3)	1.000 (25.4)	1.375 (34.9)
28	1.188 (30.2)	1.572 (39.9)	2.719 (69.1)	2.505 (63.6)	1.250 (31.8)	1.625 (41.3)

\* Not available in Style M clamp.      \*\* Not Applicable Style D

1. When maximum cable entry (page 21) is exceeded, Style 2 will be supplied. Dimensions F, G, H and J will not apply. Please consult factory.
2. Metric dimensions (mm) are indicated in parentheses.
3. O-Ring not supplied with Connector Designator A.
4. Backshells supplied with 600-052-\* band, see Glenair Series 600 Tool Catalog for installation.

**STYLE H**

Heavy Duty (Table X)

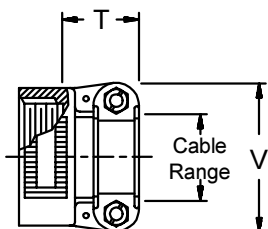

**STYLE A**

Medium Duty (Table XI)

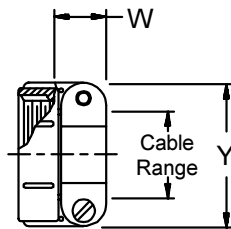

**STYLE M**

Medium Duty (Table XI)

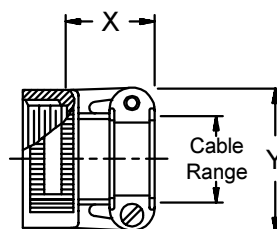

**STYLE D**

Medium Duty (Table XI)

