

**CONNECTOR
DESIGNATORS
A-F-H-L-S
ROTATABLE
COUPLING**

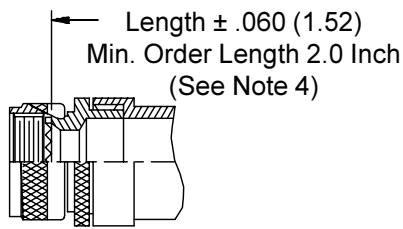

**STYLE 2
(STRAIGHT
See Note 1)**

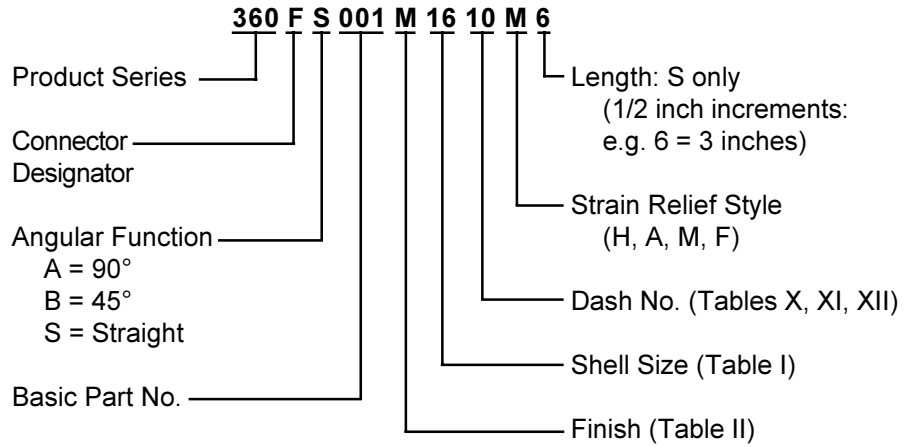
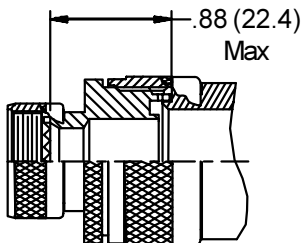
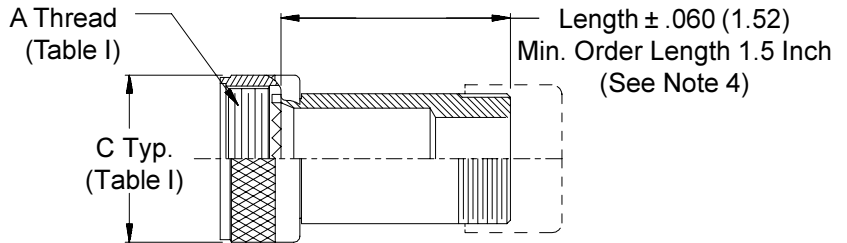

**STYLE 2
(45° - 90°
See Note 1)**

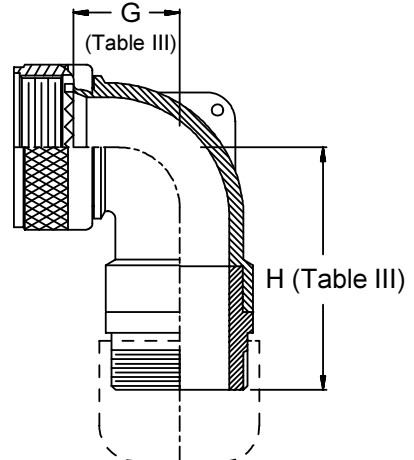
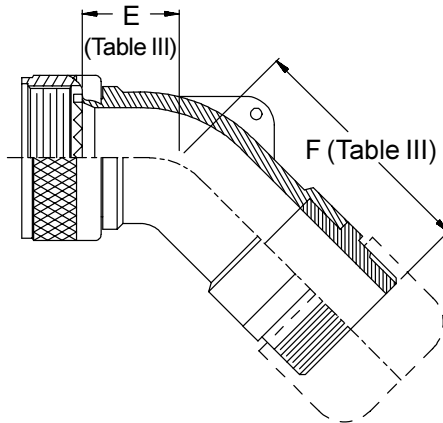

**STYLE H
Heavy Duty
(Table X)**

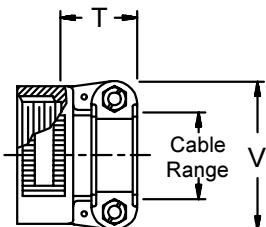

**STYLE A
Medium Duty
(Table XI)**

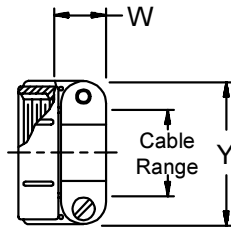

**STYLE M
Medium Duty
(Table XI)**

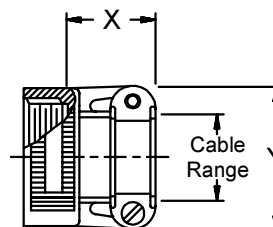

**STYLE F
Light Duty
(Table XII)**

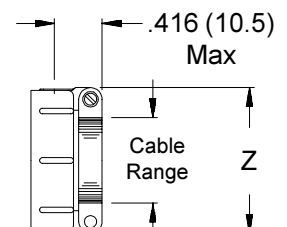

Series 36 Non-Environmental Backshells



TABLE III

Shell Size Conn. Desig. A-F-L-S H		E Max	F Max	G Max	H Max
08	09	.457 (11.6)	1.622 (41.2)	.500 (12.7)	1.632 (41.5)
10	11	.520 (13.2)	1.682 (42.7)	.595 (15.1)	1.752 (44.5)
12	13	.582 (14.8)	1.742 (44.2)	.610 (15.5)	1.772 (45.0)
14	15	.645 (16.4)	2.062 (52.4)	.700 (17.8)	2.072 (52.6)
16	17	.738 (18.7)	2.172 (55.2)	.885 (22.5)	2.162 (54.9)
18	19	.926 (23.5)	2.362 (60.0)	.975 (24.8)	2.332 (59.2)
20	21	.926 (23.5)	2.362 (60.0)	.975 (24.8)	2.332 (59.2)
22	23	1.020 (25.9)	2.512 (63.8)	1.125 (28.6)	2.442 (62.0)
24	25	1.020 (25.9)	2.512 (63.8)	1.125 (28.6)	2.442 (62.0)
28		1.145 (29.1)	2.562 (65.1)	1.225 (31.1)	2.612 (66.3)
32		1.207 (30.7)	2.662 (67.6)	1.575 (40.0)	2.862 (72.7)
36		1.238 (31.4)	2.752 (69.9)	1.775 (45.1)	2.862 (72.7)

See inside back cover
fold-out or pages 13 and
14 for Tables I and II.

TABLE X

Dash No.	T Max	V Max	Cable Range			
			Min		Max	
04	.780 (19.8)	.957 (24.3)	.125 (3.2)	.312 (7.9)		
06	.780 (19.8)	1.145 (29.1)	.250 (6.4)	.437 (11.1)		
08	.780 (19.8)	1.332 (33.8)	.312 (7.9)	.562 (14.3)		
10	.780 (19.8)	1.332 (33.8)	.350 (8.9)	.625 (15.9)		
12	.811 (20.6)	1.551 (39.4)	.500 (12.7)	.750 (19.1)		
16	.905 (23.0)	1.770 (45.0)	.625 (15.9)	.937 (23.8)		
20	1.092 (27.7)	2.113 (53.7)	.875 (22.2)	1.250 (31.8)		
24	1.124 (28.5)	2.363 (60.0)	1.000 (25.4)	1.375 (34.9)		
28	1.399 (35.5)	2.770 (70.4)	1.250 (31.8)	1.625 (41.3)		
32	1.399 (35.5)	3.020 (76.7)	1.437 (36.5)	1.875 (47.6)		

TABLE XII

Dash No.	Z Max	Cable Range			
		Min		Max	
02	.968 (24.6)	.125 (3.2)	.250 (6.4)		
03	1.046 (26.6)	.250 (6.4)	.375 (9.5)		
04	1.156 (29.4)	.312 (7.9)	.500 (12.7)		
05	1.218 (30.9)	.437 (11.1)	.625 (15.9)		
06	1.343 (34.1)	.562 (14.3)	.750 (19.1)		
07	1.468 (37.3)	.687 (17.4)	.875 (22.2)		
08	1.593 (40.5)	.812 (20.6)	1.000 (25.4)		
10	1.843 (46.8)	1.062 (27.0)	1.250 (31.8)		

TABLE XI

Dash No.	W Max	X Max	Y Max	Cable Range		
				Min		Max
03*	.437 (11.1)	.760 (19.3)	.843 (21.4)	.156 (4.0)	.250 (6.4)	
04*	.437 (11.1)	.760 (19.3)	.906 (23.0)	.188 (4.8)	.312 (7.9)	
06*	.500 (12.7)	.760 (19.3)	1.093 (27.8)	.281 (7.1)	.438 (11.1)	
08	.563 (14.3)	.760 (19.3)	1.187 (30.1)	.344 (8.7)	.562 (14.3)	
10	.563 (14.3)	.760 (19.3)	1.281 (32.5)	.375 (9.5)	.625 (15.9)	
12	.563 (14.3)	.760 (19.3)	1.500 (38.1)	.438 (11.1)	.750 (19.1)	
16	.656 (16.7)	1.073 (27.3)	1.719 (43.7)	.562 (14.3)	.938 (23.8)	
20	.656 (16.7)	1.323 (33.6)	2.062 (52.4)	.750 (19.1)	1.250 (31.8)	
24	.656 (16.7)	1.323 (33.6)	2.312 (58.7)	.781 (19.8)	1.375 (34.9)	
28	1.188 (30.2)	1.572 (39.9)	2.719 (69.1)	.969 (24.6)	1.625 (41.3)	
32*	1.187 (30.1)	1.572 (39.9)	2.969 (75.4)	1.125 (28.6)	1.875 (47.6)	
40*	1.125 (28.6)	1.572 (39.9)	3.531 (89.7)	1.469 (37.3)	2.375 (60.3)	

* Not available in Style M clamp.

1. When maximum cable entry (page 21) is exceeded, Style 2 will be supplied. Dimensions E, F, G and H will not apply. Please consult factory.
2. Metric dimensions (mm) are indicated in parentheses.
3. Cable range is defined as the accommodations range for the wire bundle or cable. Dimensions shown are not intended for inspection criteria.
4. Consult factory for shorter lengths on straight backshells.

CONNECTOR DESIGNATORS A-B*-C-D-E-F G-H-J-K-L-S

* Conn. Design. B See Note 5

DIRECT COUPLING

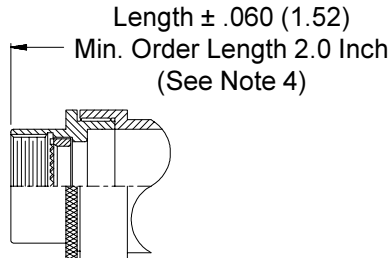
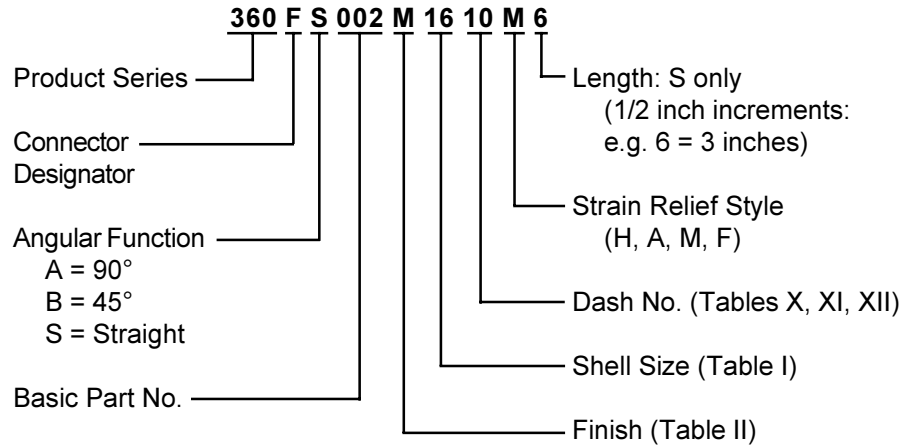

STYLE 2
(STRAIGHT - See Note 1)

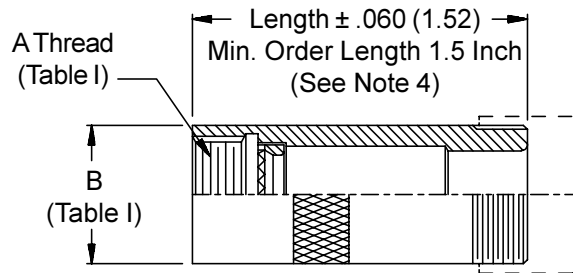

1. When maximum cable entry (page 22) is exceeded, Style 2 will be supplied. (Function S only.)
2. Metric dimensions (mm) are indicated in parentheses.
3. Cable range is defined as the accommodations range for the wire bundle or cable. Dimensions shown are not intended for inspection criteria.
4. Consult factory for shorter lengths on straight backshells.
5. When using Connector Designator B refer to pages 18 and 19 for part number development.

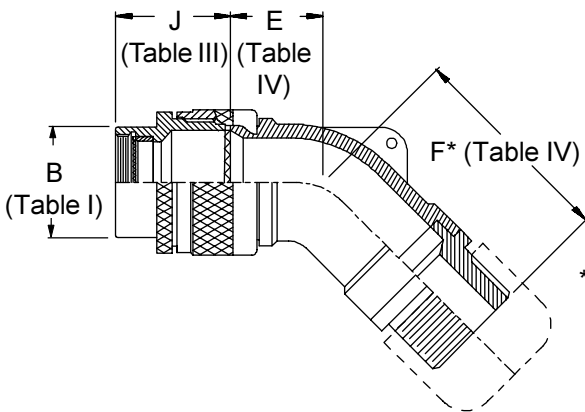

* For Style F light duty strain relief use F¹ and H¹ dimensions in Table V.

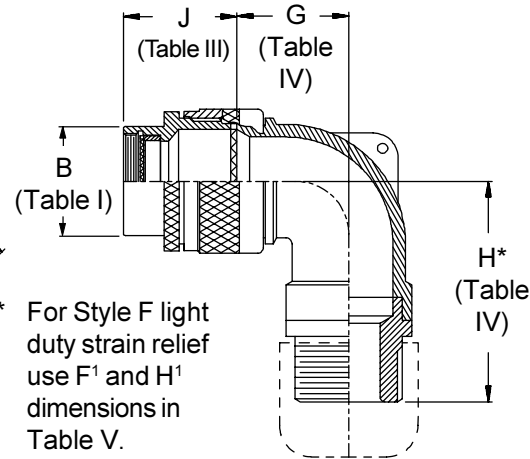

STYLE H
Heavy Duty
(Table X)

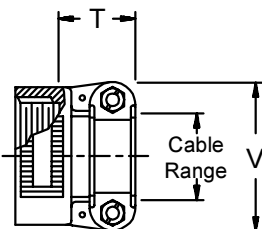

STYLE A
Medium Duty
(Table XI)

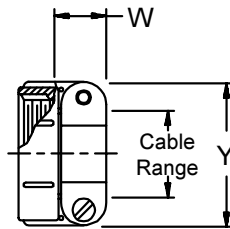

STYLE M
Medium Duty
(Table XI)

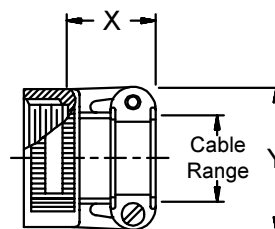

STYLE F
Light Duty
(Table XII)

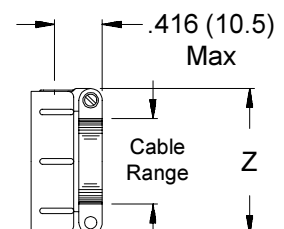

Series 36 Non-Environmental Backshells



See inside back cover
fold-out or pages 13 and
14 for Tables I and II.

TABLE III

Shell Size	J Max - Conn. Designator		
	A-D-E-F		
	J-H-L-S	B-G-K	C
08/09	1.000(25.4)	1.000(25.4)	
10/11	1.000(25.4)	1.000(25.4)	
12/13	1.000(25.4)	1.000(25.4)	1.735(44.1)
14/15	1.000(25.4)	1.000(25.4)	1.915(48.6)
16/17	1.000(25.4)	1.000(25.4)	1.915(48.6)
18/19	1.000(25.4)	1.166(29.6)	1.915(48.6)
20/21	1.000(25.4)	1.166(29.6)	1.915(48.6)
22/23	1.000(25.4)	1.166(29.6)	1.915(48.6)
24/25	1.000(25.4)	1.166(29.6)	1.915(48.6)
28	1.000(25.4)	1.166(29.6)	1.915(48.6)
32	1.000(25.4)	1.166(29.6)	1.915(48.6)
36	1.000(25.4)	1.166(29.6)	1.915(48.6)
40	1.000(25.4)	1.437(36.5)	1.915(48.6)

TABLE IV

Elbow Size	E Max	F Max	G Max	H Max
04	.567 (14.4)	1.187 (30.1)	.636 (16.2)	1.200 (30.5)
06	.630 (16.0)	1.250 (31.8)	.710 (18.0)	1.320 (33.5)
08	.692 (17.6)	1.312 (33.3)	.731 (18.6)	1.340 (34.0)
10	.755 (19.2)	1.655 (42.0)	.825 (21.0)	1.660 (42.2)
12	.848 (21.5)	1.765 (44.8)	.988 (25.1)	1.750 (44.5)
16	1.036 (26.3)	1.952 (49.6)	1.087 (27.6)	1.925 (48.9)
20	1.130 (28.7)	2.098 (53.3)	1.325 (33.7)	2.033 (51.6)
24	1.255 (31.9)	2.155 (54.7)	1.337 (34.0)	2.200 (55.9)
28	1.317 (33.5)	2.250 (57.2)	1.827 (46.4)	2.450 (62.2)
32	1.348 (34.2)	2.343 (59.5)	2.027 (51.5)	2.450 (62.2)

TABLE X

Dash No.	T Max	V Max	Cable Range	
			Min	Max
04	.780 (19.8)	.957 (24.3)	.125 (3.2)	.312 (7.9)
06	.780 (19.8)	1.145 (29.1)	.250 (6.4)	.437 (11.1)
08	.780 (19.8)	1.332 (33.8)	.312 (7.9)	.562 (14.3)
10	.780 (19.8)	1.332 (33.8)	.350 (8.9)	.625 (15.9)
12	.811 (20.6)	1.551 (39.4)	.500 (12.7)	.750 (19.1)
16	.905 (23.0)	1.770 (45.0)	.625 (15.9)	.937 (23.8)
20	1.092 (27.7)	2.113 (53.7)	.875 (22.2)	1.250 (31.8)
24	1.124 (28.5)	2.363 (60.0)	1.000 (25.4)	1.375 (34.9)
28	1.399 (35.5)	2.770 (70.4)	1.250 (31.8)	1.625 (41.3)
32	1.399 (35.5)	3.020 (76.7)	1.437 (36.5)	1.875 (47.6)

TABLE XII

Dash No.	Z Max	Cable Range	
		Min	Max
02	.968 (24.6)	.125 (3.2)	.250 (6.4)
03	1.046 (26.6)	.250 (6.4)	.375 (9.5)
04	1.156 (29.4)	.312 (7.9)	.500 (12.7)
05	1.218 (30.9)	.437 (11.1)	.625 (15.9)
06	1.343 (34.1)	.562 (14.3)	.750 (19.1)
07	1.468 (37.3)	.687 (17.4)	.875 (22.2)
08	1.593 (40.5)	.812 (20.6)	1.000 (25.4)
10	1.843 (46.8)	1.062 (27.0)	1.250 (31.8)

TABLE XI

Dash No.	W Max	X Max	Y Max	Cable Range	
				Min	Max
03*	.437 (11.1)	.760 (19.3)	.843 (21.4)	.156 (4.0)	.250 (6.4)
04*	.437 (11.1)	.760 (19.3)	.906 (23.0)	.188 (4.8)	.312 (7.9)
06*	.500 (12.7)	.760 (19.3)	1.093 (27.8)	.281 (7.1)	.438 (11.1)
08	.563 (14.3)	.760 (19.3)	1.187 (30.1)	.344 (8.7)	.562 (14.3)
10	.563 (14.3)	.760 (19.3)	1.281 (32.5)	.375 (9.5)	.625 (15.9)
12	.563 (14.3)	.760 (19.3)	1.500 (38.1)	.438 (11.1)	.750 (19.1)
16	.656 (16.7)	1.073 (27.3)	1.719 (43.7)	.562 (14.3)	.938 (23.8)
20	.656 (16.7)	1.323 (33.6)	2.062 (52.4)	.750 (19.1)	1.250 (31.8)
24	.656 (16.7)	1.323 (33.6)	2.312 (58.7)	.781 (19.8)	1.375 (34.9)
28	1.188 (30.2)	1.572 (39.9)	2.719 (69.1)	.969 (24.6)	1.625 (41.3)
32*	1.187 (30.1)	1.572 (39.9)	2.969 (75.4)	1.125 (28.6)	1.875 (47.6)
40*	1.125 (28.6)	1.572 (39.9)	3.531 (89.7)	1.469 (37.3)	2.375 (60.3)

* Not available in Style M clamp.

TABLE V

Elbow Size	F ¹ Max
	04
06	1.610 (40.9)
08	1.670 (42.4)
10	1.760 (44.7)
12	1.870 (47.5)
16	2.060 (52.3)
20	2.210 (56.1)

Elbow Size	H ¹ Max
	04
06	1.680 (42.7)
08	1.700 (43.2)
10	1.770 (45.0)
12	1.860 (47.2)
16	2.030 (51.6)
20	2.140 (54.4)

**CONNECTOR
DESIGNATORS
A-F-H-L-S
SELF-LOCKING
ROTATABLE
COUPLING**

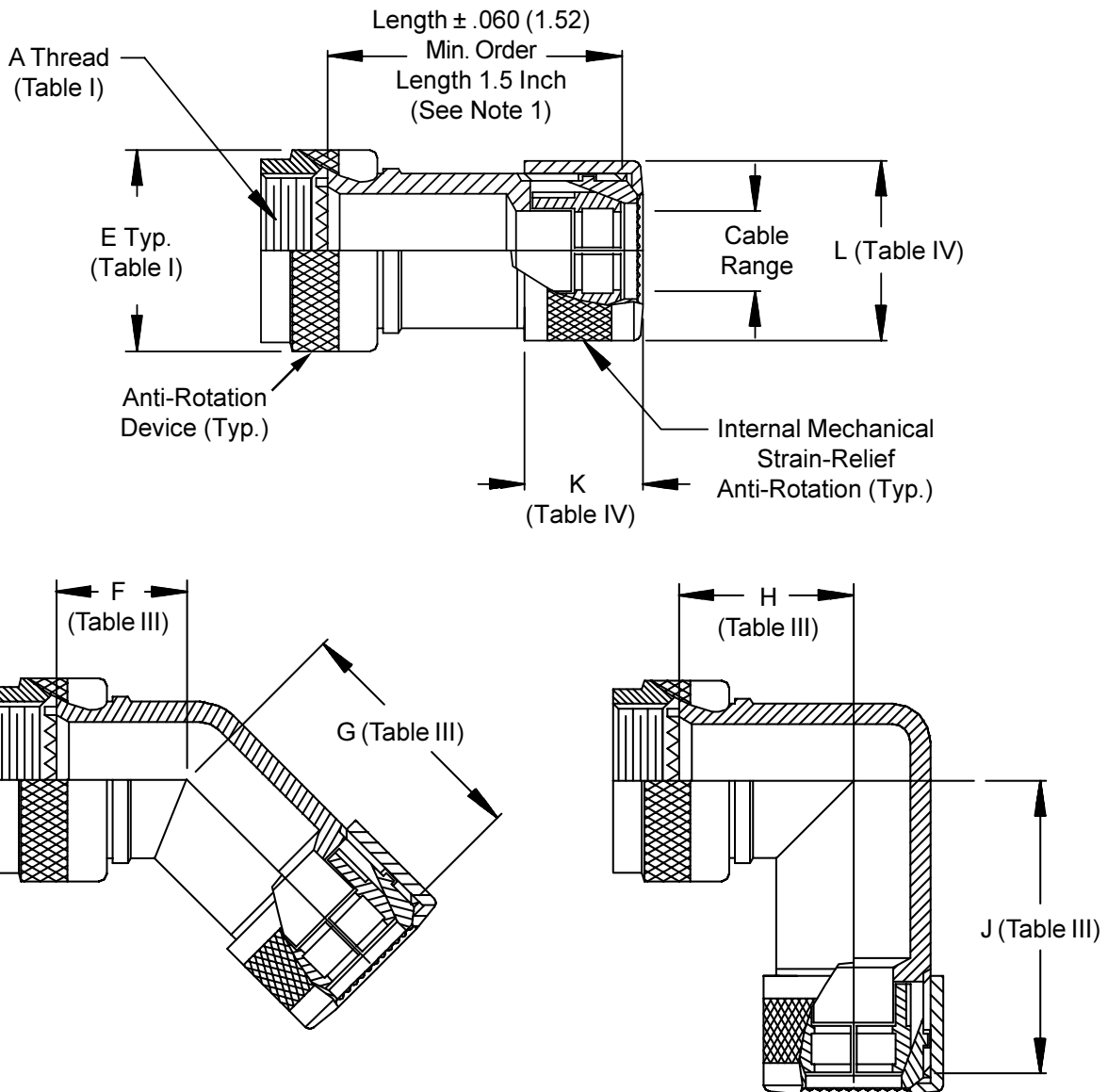
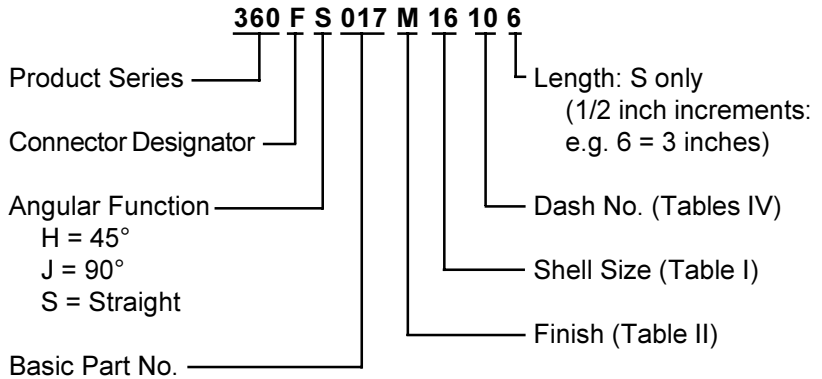

Series 36 Non-Environmental Backshells



See inside back cover
fold-out or pages 13 and
14 for Tables I and II.

Shell Size		F	G	H	J
Conn. Desig.	H	Max	Max	Max	Max
A-F-L-S					
08	09	.795 (20.2)	1.390 (35.3)	.906 (23.0)	1.500 (38.1)
10	11	.820 (20.8)	1.420 (36.1)	.966 (24.5)	1.560 (39.6)
12	13	.844 (21.4)	1.440 (36.6)	1.026 (26.1)	1.620 (41.1)
14	15	.861 (21.9)	1.470 (37.3)	1.076 (27.3)	1.690 (42.9)
16	17	.888 (22.6)	1.490 (37.8)	1.136 (28.9)	1.750 (44.5)
18	19	.904 (23.0)	1.500 (38.1)	1.176 (29.9)	1.770 (45.0)
20	21	.929 (23.6)	1.520 (38.6)	1.236 (31.4)	1.830 (46.5)
22	23	.956 (24.3)	1.560 (39.6)	1.296 (32.9)	1.910 (48.5)
24	25	.979 (24.9)	1.590 (40.4)	1.356 (34.4)	1.980 (50.3)
28		1.197 (30.4)	1.760 (44.7)	1.636 (41.6)	2.220 (56.4)
32		1.280 (32.5)	1.800 (45.7)	1.780 (45.2)	2.310 (58.7)
36		1.294 (32.9)	1.850 (47.0)	1.876 (47.7)	2.420 (61.5)
40		1.340 (34.0)	1.890 (48.0)	1.986 (50.4)	2.530 (64.3)
44		1.360 (34.5)	1.940 (49.3)	2.235 (56.8)	2.650 (67.3)

Dash No.	K Max	L Max	Cable Range	
			Min	Max
08	.530 (13.5)	.720 (18.3)	.128 (3.3)	.250 (6.4)
12	.710 (18.0)	.910 (23.1)	.233 (5.9)	.375 (9.5)
16	.720 (18.3)	1.090 (27.7)	.358 (9.1)	.500 (12.7)
20	.720 (18.3)	1.220 (31.0)	.482 (12.2)	.625 (15.9)
24	.660 (16.8)	1.340 (34.0)	.545 (13.8)	.750 (19.1)
28	.790 (20.1)	1.530 (38.9)	.670 (17.0)	.875 (22.2)
32	.870 (22.1)	1.720 (43.7)	.795 (20.2)	1.000 (25.4)
36	.830 (21.1)	1.850 (47.0)	.889 (22.6)	1.125 (28.6)
40	.820 (20.8)	1.970 (50.0)	1.014 (25.8)	1.250 (31.8)
44	.910 (23.1)	2.090 (53.1)	1.155 (29.3)	1.375 (34.9)
48	.900 (22.9)	2.280 (57.9)	1.280 (32.5)	1.500 (38.1)

1. Consult factory for shorter lengths on straight backshells.
2. Metric dimensions (mm) are indicated in parentheses.
3. Cable range is defined as the accommodations range for the wire bundle or cable.
Dimensions shown are not intended for inspection criteria.

**CONNECTOR
DESIGNATOR**

G

**ROTATABLE
COUPLING**

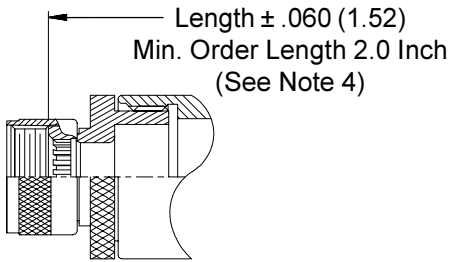
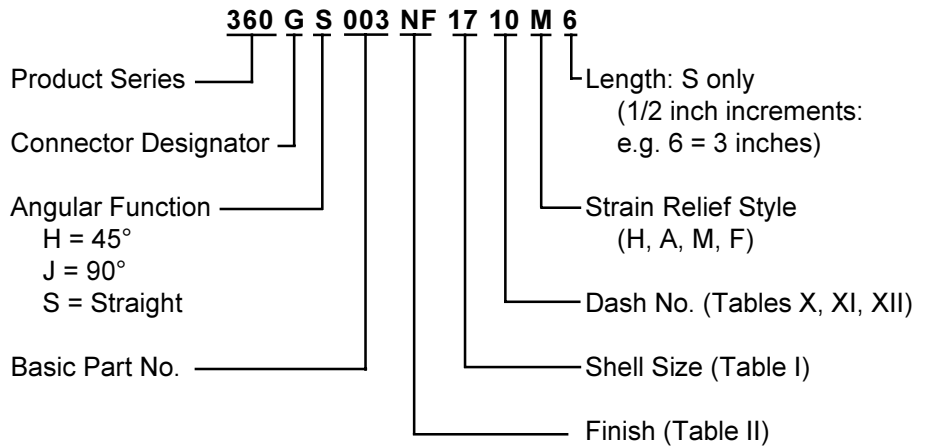

**STYLE 2
(STRAIGHT
See Note 1)**

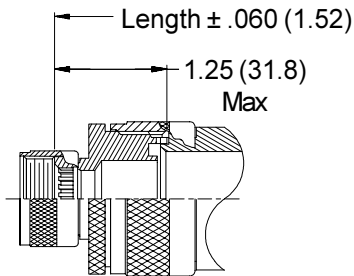
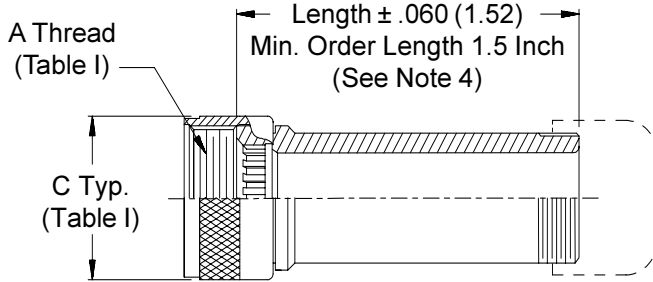

**STYLE 2
(45° & 90°
See Note 1)**

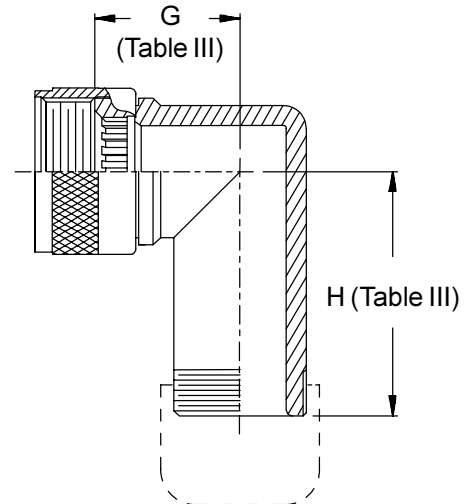
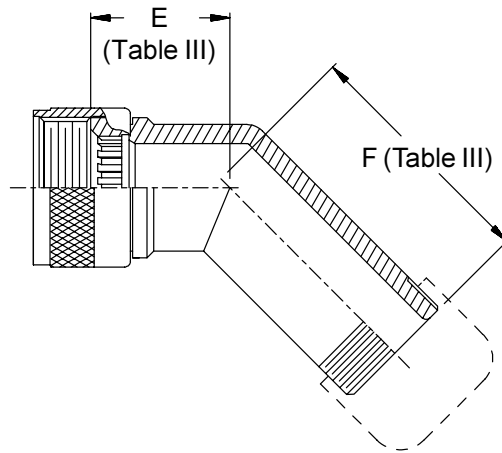

**STYLE H
Heavy Duty
(Table X)**

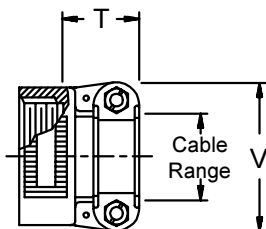

**STYLE A
Medium Duty
(Table XI)**

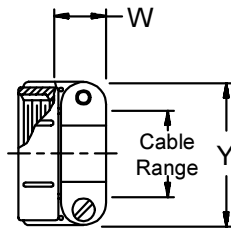

**STYLE M
Medium Duty
(Table XI)**

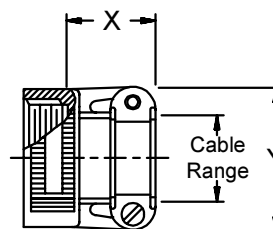

**STYLE F
Light Duty
(Table XII)**

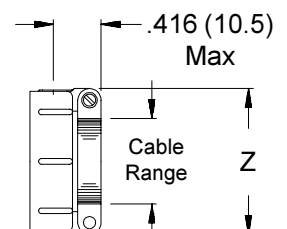

Series 36 Non-Environmental Backshells



TABLE III

Shell Size	E Max	F Max	G Max	H Max
11	1.240 (31.5)	.920 (23.4)	1.380 (35.1)	1.060 (26.9)
13	1.260 (32.0)	.940 (23.9)	1.440 (36.6)	1.120 (28.4)
15	1.290 (32.8)	.970 (24.6)	1.500 (38.1)	1.190 (30.2)
17	1.310 (33.3)	.990 (25.1)	1.570 (39.9)	1.250 (31.8)
19	1.340 (34.0)	1.020 (25.9)	1.630 (41.4)	1.330 (33.8)
23	1.380 (35.1)	1.060 (26.9)	1.730 (43.9)	1.410 (35.8)
25	1.410 (35.8)	1.090 (27.7)	1.800 (45.7)	1.480 (37.6)
29	1.580 (40.1)	1.260 (32.0)	2.040 (51.8)	1.720 (43.7)
33	1.620 (41.1)	1.300 (33.0)	2.130 (54.1)	1.810 (46.0)

See inside back cover fold-out or pages 13 and 14 for Tables I and II.

TABLE X

Dash No.	T Max	V Max	Cable Range			
			Min	Max	Min	Max
04	.780 (19.8)	.957 (24.3)	.125 (3.2)	.312 (7.9)	.125 (3.2)	.312 (7.9)
06	.780 (19.8)	1.145 (29.1)	.250 (6.4)	.437 (11.1)	.250 (6.4)	.437 (11.1)
08	.780 (19.8)	1.332 (33.8)	.312 (7.9)	.562 (14.3)	.312 (7.9)	.562 (14.3)
10	.780 (19.8)	1.332 (33.8)	.350 (8.9)	.625 (15.9)	.350 (8.9)	.625 (15.9)
12	.811 (20.6)	1.551 (39.4)	.500 (12.7)	.750 (19.1)	.500 (12.7)	.750 (19.1)
16	.905 (23.0)	1.770 (45.0)	.625 (15.9)	.937 (23.8)	.625 (15.9)	.937 (23.8)
20	1.092 (27.7)	2.113 (53.7)	.875 (22.2)	1.250 (31.8)	.875 (22.2)	1.250 (31.8)
24	1.124 (28.5)	2.363 (60.0)	1.000 (25.4)	1.375 (34.9)	1.000 (25.4)	1.375 (34.9)
28	1.399 (35.5)	2.770 (70.4)	1.250 (31.8)	1.625 (41.3)	1.250 (31.8)	1.625 (41.3)
32	1.399 (35.5)	3.020 (76.7)	1.437 (36.5)	1.875 (47.6)	1.437 (36.5)	1.875 (47.6)

TABLE XII

Dash No.	Z Max	Cable Range			
		Min	Max	Min	Max
02	.968 (24.6)	.125 (3.2)	.250 (6.4)	.125 (3.2)	.250 (6.4)
03	1.046 (26.6)	.250 (6.4)	.375 (9.5)	.250 (6.4)	.375 (9.5)
04	1.156 (29.4)	.312 (7.9)	.500 (12.7)	.312 (7.9)	.500 (12.7)
05	1.218 (30.9)	.437 (11.1)	.625 (15.9)	.437 (11.1)	.625 (15.9)
06	1.343 (34.1)	.562 (14.3)	.750 (19.1)	.562 (14.3)	.750 (19.1)
07	1.468 (37.3)	.687 (17.4)	.875 (22.2)	.687 (17.4)	.875 (22.2)
08	1.593 (40.5)	.812 (20.6)	1.000 (25.4)	.812 (20.6)	1.000 (25.4)
10	1.843 (46.8)	1.062 (27.0)	1.250 (31.8)	1.062 (27.0)	1.250 (31.8)

TABLE XI

Dash No.	W Max	X Max	Y Max	Cable Range			
				Min	Max	Min	Max
03*	.437 (11.1)	.760 (19.3)	.843 (21.4)	.156 (4.0)	.250 (6.4)	.156 (4.0)	.250 (6.4)
04*	.437 (11.1)	.760 (19.3)	.906 (23.0)	.188 (4.8)	.312 (7.9)	.188 (4.8)	.312 (7.9)
06*	.500 (12.7)	.760 (19.3)	1.093 (27.8)	.281 (7.1)	.438 (11.1)	.281 (7.1)	.438 (11.1)
08	.563 (14.3)	.760 (19.3)	1.187 (30.1)	.344 (8.7)	.562 (14.3)	.344 (8.7)	.562 (14.3)
10	.563 (14.3)	.760 (19.3)	1.281 (32.5)	.375 (9.5)	.625 (15.9)	.375 (9.5)	.625 (15.9)
12	.563 (14.3)	.760 (19.3)	1.500 (38.1)	.438 (11.1)	.750 (19.1)	.438 (11.1)	.750 (19.1)
16	.656 (16.7)	1.073 (27.3)	1.719 (43.7)	.562 (14.3)	.938 (23.8)	.562 (14.3)	.938 (23.8)
20	.656 (16.7)	1.323 (33.6)	2.062 (52.4)	.750 (19.1)	1.250 (31.8)	.750 (19.1)	1.250 (31.8)
24	.656 (16.7)	1.323 (33.6)	2.312 (58.7)	.781 (19.8)	1.375 (34.9)	.781 (19.8)	1.375 (34.9)
28	1.188 (30.2)	1.572 (39.9)	2.719 (69.1)	.969 (24.6)	1.625 (41.3)	.969 (24.6)	1.625 (41.3)
32*	1.187 (30.1)	1.572 (39.9)	2.969 (75.4)	1.125 (28.6)	1.875 (47.6)	1.125 (28.6)	1.875 (47.6)
40*	1.125 (28.6)	1.572 (39.9)	3.531 (89.7)	1.469 (37.3)	2.375 (60.3)	1.469 (37.3)	2.375 (60.3)

* Not available in Style M clamp.

1. When maximum cable entry (pages 21) is exceeded, Style 2 will be supplied. Dimensions E, F, G and H will not apply. Please consult factory.
2. Metric dimensions (mm) are indicated in parentheses.
3. Cable range is defined as the accommodations range for the wire bundle or cable. Dimensions shown are not intended for inspection criteria.
4. Consult factory for shorter lengths on straight backshells.